

# No.35 | Taper bore Sprockets

- Pitch  $\frac{3}{8}$ "
- Roller  $\phi$  0.200"
- Tooth width B1 0.168"

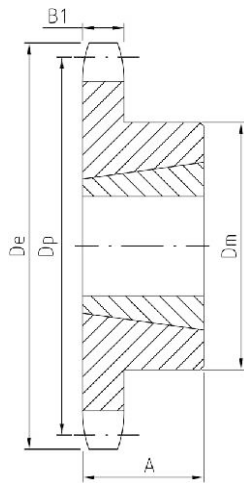

TYPE B



## Single-Taper Bushed

No. Teeth	Part Number	Bushing	De	Dp	Max. Bore	A	C	Type	Weight(Approx.)	
									Rim Only	Bushing Only
18	35BTB18	1008	2.352	2.159	1	7/8	17/8 ★	B	.4	.3
19	35BTB19	1008	2.472	2.278	1	7/8	1 13/16	B	.5	.3
20	35BTB20	1008	2.593	2.397	1	7/8	1 5/16	B	.6	.3
21	35BTB21	1008	2.713	2.516	1	7/8	2 1/16	B	.7	.3
22	35BTB22	1210	2.883	2.635	1 1/4	1	2 3/8 ★	B	.8	.6
23	35BTB23	1210	2.954	2.754	1 1/4	1	2 1/16	B	.9	.6
24	35BTB24	1210	3.074	2.873	1 1/4	1	2 1/16	B	.9	.6
25	35BTB25	1210	3.194	2.992	1 1/4	1	2 1/16	B	1.2	.6
26	35BTB26	1610	3.314	3.111	1 1/8	1	2 7/8 ★	B	1.1	.9
28	35BTB28	1610	3.553	3.349	1 1/8	1	2 7/8	B	1.2	.9
30	35BTB30	1610	3.793	3.588	1 1/8	1	3 1/8	B	1.2	.9
32	35BTB32	1610	4.032	3.826	1 1/8	1	3 1/4	B	1.3	.9
35	35BTB35	1610	4.392	4.183	1 1/8	1	3 3/4	B	1.4	.9
36	35BTB36	1610	4.511	4.303	1 1/8	1	3 3/4	B	1.4	.9
40	35BTB40	1610	4.990	4.786	1 1/8	1	3 3/4	B	1.9	.9
42	35BTB42	1610	5.229	5.018	1 1/8	1	3 3/4	B	2.0	.9
45	35BTB45	1610	5.588	5.376	1 1/8	1	3 3/4	B	2.1	.9
48	35BTB48	1610	5.946	5.734	1 1/8	1	3 3/4	B	2.3	.9
54	35BTB54	1610	6.663	6.449	1 1/8	1	3 3/4	B	2.6	.9
60	35BTB60	1610	7.380	7.165	1 1/8	1	3 3/4	B	3.0	.9
70	35BTB70	1610	8.575	8.358	1 1/8	1	3 3/4	B	3.7	.9
72	35BTB72	1610	8.814	8.597	1 1/8	1	3 3/4	B	3.9	.9
80	35BTB80	1610	9.770	9.552	1 1/8	1	3 3/4	B	4.5	.9
84	35BTB84	1610	10.247	10.029	1 1/8	1	3 3/4	B	4.9	.9
96	35BTB96	1610	11.680	11.461	1 1/8	1	3 3/4	B	6.0	.9
112	35BTB112	1610	13.590	13.371	1 1/8	1	3 3/4	B	7.8	.9

★ Has recessed groove in hub for chain clearance.

# No.35-2 | Taper bore Sprockets

- Pitch  $\frac{3}{8}$ "
- Roller  $\phi$  0.200"
- Tooth width b1 0.162"
- Tooth width B2 0.561"

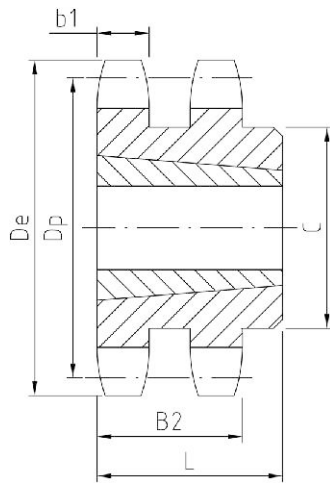

TYPE B

## Double-Taper Bushed

No. Teeth	Part Number	Bushing	De	Dp	Max. Bore	L	C	Type	Weight(Approx.)	
									Rim Only	Bushing Only
19	D35BTB19H	1008	2.472	2.278	1	$\frac{7}{8}$	$\frac{49}{64}$	B	.6	.3
20	D35BTB20H	1008	2.593	2.397	1	$\frac{7}{8}$	$\frac{19}{16}$	B	.8	.3
21	D35BTB21H	1008	2.713	2.516	1	$\frac{7}{8}$	$\frac{2}{16}$	B	1.4	.3
22	D35BTB22H	1008	2.883	2.635	1	$\frac{7}{8}$	$\frac{2}{16}$	B	1.7	.3
24	D35BTB24H	1210	3.074	2.873	$\frac{1}{4}$	1	$\frac{2}{16}$	B	1.8	.6
26	D35BTB26	1210	3.314	3.111	$\frac{1}{4}$	1	$\frac{2}{8}$	B	2.0	.6
30	D35BTB30	1610	3.793	3.588	$\frac{1}{8}$	1	$\frac{3}{8}$	B	1.8	.9
32	D35BTB32	1610	4.032	3.826	$\frac{1}{8}$	1	$\frac{3}{4}$	B	2.0	.9
35	D35BTB35	1610	4.392	4.183	$\frac{1}{8}$	1	$\frac{3}{4}$	B	2.3	.9
40	D35BTB40	1610	4.990	4.780	$\frac{1}{8}$	1	$\frac{3}{4}$	B	2.9	.9
45	D35BTB45	1610	5.588	5.376	$\frac{1}{8}$	1	$\frac{3}{4}$	B	3.2	.9
48	D35BTB48	1610	5.946	5.734	$\frac{1}{8}$	1	$\frac{3}{8}$	B	3.5	.9
54	D35BTB54	1610	6.663	6.449	$\frac{1}{8}$	1	$\frac{3}{8}$	B	3.9	.9
60	D35BTB60	1610	7.380	7.165	$\frac{1}{8}$	1	$\frac{3}{8}$	B	4.9	.9
70	D35BTB70	1610	8.575	8.358	$\frac{1}{8}$	1	$\frac{3}{8}$	B	6.3	.9
80	D35BTB80	1610	9.770	9.552	$\frac{1}{8}$	1	$\frac{3}{8}$	B	7.9	.9
96	D35BTB96	1610	11.680	11.461	$\frac{1}{8}$	1	$\frac{3}{8}$	B	9.9	.9
112	D35BTB112	1610	13.590	13.371	$\frac{1}{8}$	1	$\frac{3}{8}$	B	10.9	.9

Taper Bore Sprockets

# No.41 | Taper bore Sprockets

- Pitch  $1/2''$
- Roller  $\phi$  0.306''
- Tooth width B1 0.227''

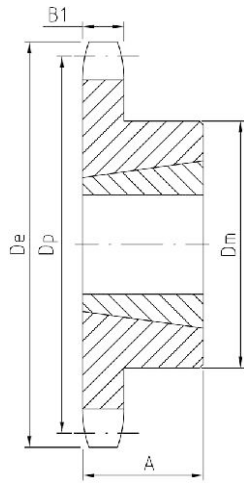

TYPE B

## Single-Taper Bushed

No. Teeth	Part Number	Bushing	De	Dp	Max. Bore	L	C	Type	Weight(Approx.)	
									Rim Only	Bushing Only
14	41BTB14	1008	2.49	2.249	1	7/8	1 7/8 ★	B	.4	.3
15	41BTB15	1008	2.65	2.405	1	7/8	1 7/8	B	.5	.3
16	41BTB16	1008	2.81	2.503	1	7/8	2	B	.6	.3
17	41BTB17	1210	2.98	2.721	1 1/4	1	2 3/8 ★	B	.7	.6
18	41BTB18	1210	3.14	2.879	1 1/4	1	2 3/8	B	.9	.6
19	41BTB19	1210	3.30	3.038	1 1/4	1	2 1/2	B	1.1	.9
20	41BTB20	1610	3.46	3.196	1 1/2	1	2 7/8 ★	B	1.1	.9
21	41BTB21	1610	3.62	3.355	1 1/2	1	3 ★	B	1.2	.9
22	41BTB22	1610	3.78	3.573	1 1/2	1	3	B	1.3	.9
23	41BTB23	1610	3.94	3.672	1 1/2	1	3	B	1.4	.9
24	41BTB24	1610	4.10	3.831	1 1/2	1	3 1/4	B	1.4	.9
25	41BTB25	1610	4.26	3.989	1 1/2	1	3 1/4	B	1.5	.9
26	41BTB26	1610	4.42	4.148	1 1/2	1	3 1/4	B	1.5	.9
28	41BTB28	1610	4.74	4.466	1 1/2	1	3 1/4	B	1.7	.9
30	41BTB30	1610	5.06	4.783	1 1/2	1	3 1/4	B	1.8	.9
32	41BTB32	1610	5.38	5.101	1 1/2	1	3 1/4	B	1.9	.9
35	41BTB35	1610	5.86	5.578	1 1/2	1	3 1/4	B	2.3	.9
36	41BTB36	1610	6.02	5.737	1 1/2	1	3 1/4	B	2.4	.9
40	41BTB40	1610	6.65	6.373	1 1/2	1	3 1/4	B	2.7	.9
45	41BTB45	1610	7.45	7.168	1 1/2	1	3 1/4	B	3.5	.9
48	41BTB48	1610	7.93	7.645	1 1/2	1	3 1/4	B	4.1	.9
54	41BTB54	1610	8.89	8.599	1 1/2	1	3 1/4	B	4.9	.9
60	41BTB60	1610	9.84	9.554	1 1/2	1	3 1/4	B	5.7	.9
70	41BTB70	1610	11.43	11.145	1 1/2	1	3 1/4	B	7.4	.9
72	41BTB72	1610	11.75	11.463	1 1/2	1	3 1/4	B	8.2	.9
80	41BTB80	1610	13.03	12.736	1 1/2	1	3 1/4	B	9.6	.9
96	41BTB96	1610	15.57	15.281	1 1/2	1	3 1/4	B	13.1	.9

★ Has recessed groove in hub for chain clearance.

# No.40 | Taper bore Sprockets

- Pitch  $1\frac{1}{2}$ "
- Roller  $\phi$  0.312"
- Tooth width B1 0.284"

## Single-Taper Bushed with Hardened Teeth

No. Teeth	Part Number
14	40BTB14H
15	40BTB15H
16	40BTB16H
17	40BTB17H
18	40BTB18H
19	40BTB19H
20	40BTB20H
21	40BTB21H
22	40BTB22H
23	40BTB23H
24	40BTB24H
25	40BTB25H
26	40BTB26H
28	40BTB28H
30	40BTB30H

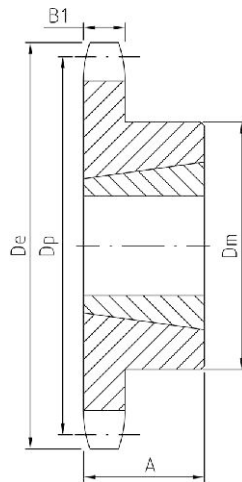

TYPE B



## Single-Taper Bushed

No. Teeth	Part Number	Bushing	De	Dp	Max. Bore	L	C	Type	Weight(Approx.)	
									Rim Only	Bushing Only
14	40BTB14	1008	2.491	2.247	1	$\frac{7}{8}$	★ $1\frac{3}{16}$	B	.3	.3
15	40BTB15	1008	2.652	2.405	1	$\frac{7}{8}$	$1\frac{3}{16}$	B	.4	.3
16	40BTB16	1008	2.814	2.563	1	$\frac{7}{8}$	$1\frac{9}{16}$	B	.5	.3
17	40BTB17	1210	2.975	2.721	$1\frac{1}{4}$	1	★ $2\frac{3}{8}$	B	.5	.3
18	40BTB18	1210	3.315	2.879	$1\frac{1}{4}$	1	★ $2\frac{1}{2}$	B	.6	.6
19	40BTB19	1210	3.296	3.038	$1\frac{1}{4}$	1	$2\frac{1}{2}$	B	.7	.6
20	40BTB20	1610	3.457	3.196	$1\frac{5}{8}$	1	★ $2\frac{5}{8}$	B	.7	.9
21	40BTB21	1610	3.617	3.355	$1\frac{5}{8}$	1	$2\frac{5}{8}$	B	.8	.9
22	40BTB22	1610	3.778	3.513	$1\frac{5}{8}$	1	$2\frac{5}{8}$	B	.9	.9
23	40BTB23	1610	3.938	3.672	$1\frac{5}{8}$	1	3	B	1.0	.9
24	40BTB24	1610	4.098	3.831	$1\frac{5}{8}$	1	$3\frac{1}{4}$	B	1.4	.9
25	40BTB25	1610	4.258	3.989	$1\frac{5}{8}$	1	$3\frac{1}{4}$	B	1.5	.9
26	40BTB26	1610	4.418	4.148	$1\frac{5}{8}$	1	$3\frac{1}{4}$	B	1.7	.9
28	40BTB28	1610	4.738	4.466	$1\frac{5}{8}$	1	3	B	1.8	.9
30	40BTB30	1610	5.057	4.783	$1\frac{5}{8}$	1	3	B	1.9	.9
32	40BTB32	1610	5.377	5.101	$1\frac{5}{8}$	1	3	B	1.9	.9
35	40BTB35	1610	5.855	5.578	$1\frac{5}{8}$	1	3	B	2.3	.9
36	40BTB36	1610	6.015	5.737	$1\frac{5}{8}$	1	3	B	2.4	.9
40	40BTB40	1610	6.653	6.373	$1\frac{5}{8}$	1	3	B	2.8	.9
42	40BTB42	1610	6.972	6.691	$1\frac{5}{8}$	1	3	B	2.9	.9
45	40BTB45	1610	7.451	7.168	$1\frac{5}{8}$	1	3	B	3.5	.9
48	40BTB48	1610	7.928	7.645	$1\frac{5}{8}$	1	3	B	4.0	.9
54	40BTB54	1610	8.885	8.599	$1\frac{5}{8}$	1	3	B	4.9	.9
60	40BTB60	1610	9.841	9.554	$1\frac{5}{8}$	1	3	B	6.0	.9
70	40BTB70	2012	11.434	11.145	2	$1\frac{1}{4}$	$3\frac{9}{16}$	B	8.2	1.7
72	40BTB72	2012	11.752	11.463	2	$1\frac{1}{4}$	$3\frac{9}{16}$	B	9.0	1.7
80	40BTB80	2012	13.026	12.736	2	$1\frac{1}{4}$	$3\frac{9}{16}$	B	10.8	1.7
84	40BTB84	2012	13.663	13.372	2	$1\frac{1}{4}$	$3\frac{9}{16}$	B	11.3	1.7
96	40BTB96	2012	15.573	15.282	2	$1\frac{1}{4}$	$3\frac{9}{16}$	B	14.6	1.7
112	40BTB112	2517	18.122	17.828	$2\frac{1}{2}$	$1\frac{3}{4}$	$4\frac{1}{4}$	B	20.5	1.7

★ Has recessed groove in hub for chain clearance.

# No.40-2 | Taper bore Sprockets

- Pitch  $1/2''$
- Roller  $\phi$   $0.312''$
- Tooth width b1  $0.275''$
- Tooth width B2  $0.841''$

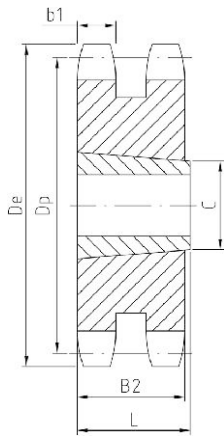

TYPE A

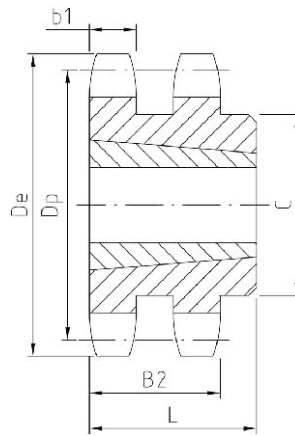

TYPE B

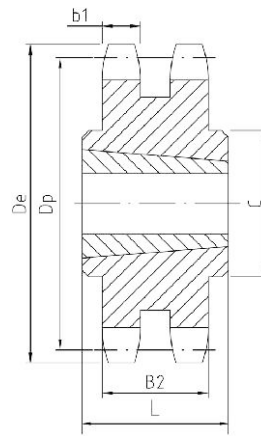

TYPE C

## Double-Taper Bushed

No. Teeth	Part Number	Bushing	De	Dp	Max. Bore	L	C	Type	Weight(Approx.)	
									Rim Only	Bushing Only
15	D40ATB15H	1008	2.652	2.405	1	7/8	17/64	A	.5	.3
16	D40ATB16H	1008	2.814	2.563	1	7/8	17/64	A	.6	.3
17	D40ATB17H	1008	2.975	2.721	1	7/8	17/64	A	.7	.3
18	D40BTB18H	1210	3.135	2.879	1 1/4	1	2 1/16	B	.7	.6
19	D40BTB19H	1210	3.296	3.038	1 1/4	1	2 1/2	B	.9	.6
20	D40BTB20H	1610	3.457	3.196	1 5/8	1	2 5/8	B	.9	.9
21	D40BTB21H	1610	3.617	3.355	1 5/8	1	2 3/4	B	1.0	.9
23	D40BTB23H	1610	3.938	3.672	1 5/8	1	3	B	1.3	.9
25	D40BTB25H	2012	4.258	3.989	2	1 1/4	3 3/32	B	1.6	1.7
30	D40BTB30	2012	5.057	4.783	2	1 1/4	4 15/64	B	3.4	1.7
36	D40BTB36	2012	6.015	5.737	2	1 1/4	5 3/32	B	5.9	1.7
42	D40CTB42	2517	6.972	6.691	2 1/2	1 1/4	4 1/4	C	7.0	3.5
48	D40CTB48	2517	7.928	7.645	2 1/2	1 1/4	4 1/4	C	9.6	3.5
52	D40CTB52	2517	8.566	8.281	2 1/2	1 1/4	4 1/4	C	11.4	3.5
60	D40CTB60	2517	9.841	9.554	2 1/2	1 1/4	4 1/4	C	15.4	3.5
68	D40CTB68	2517	11.115	10.826	2 1/2	1 1/4	4 1/4	C	20.5	3.5
76	D40CTB76	2517	12.389	12.099	2 1/2	1 1/4	4 1/4	C	25.7	3.5
84	D40CTB84	2517	13.663	13.372	2 1/2	1 1/4	4 1/4	C	31.6	3.5
95	D40CTB95	2517	15.414	15.122	2 1/2	1 1/4	4 1/4	C	34.1	3.5
102	D40CTB102	2517	16.529	16.236	2 1/2	1 1/4	4 1/4	C	36.8	3.5



NOTE: Double 40 stock sprockets with 25 teeth or less have hardened teeth.

# No.50 | Taper bore Sprockets

- Pitch  $5/8''$
- Roller  $\phi$  0.400''
- Tooth width B1 0.343''

## Single-Taper Bushed with Hardened Teeth

No. Teeth	Part Number
12	50BTB12H
13	50BTB13H
14	50BTB14H
15	50BTB15H
16	50BTB16H
17	50BTB17H
18	50BTB18H
19	50BTB19H
20	50BTB20H
21	50BTB21H
22	50BTB22H
23	50BTB23H
24	50BTB24H
25	50BTB25H
26	50BTB26H
27	50BTB27H
28	50BTB28H
30	50BTB30H

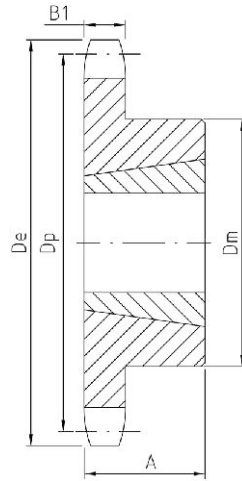

TYPE B

## Single-Taper Bushed

No. Teeth	Part Number	Bushing	De	Dp	Max. Bore	L	C	Type	Weight(Approx.)	
									Rim Only	Bushing Only
12	50BTB12	1008	2.708	2.415	1	7/8	1 <sup>15/16</sup> ★	B	.5	.3
13	50BTB13	1008	2.911	2.612	1	7/8	1 <sup>9/16</sup>	B	.5	.3
14	50BTB14	1008	3.113	2.809	1	7/8	1 <sup>5/16</sup>	B	.6	.3
15	50BTB15	1210	3.315	3.006	1	1/4	2 <sup>15/32</sup> ★	B	.7	.6
16	50BTB16	1610	3.517	3.204	1	1/8	2 <sup>25/32</sup> ★	B	.7	.9
17	50BTB17	1610	3.719	3.401	1	1/8	2 <sup>25/32</sup> ★	B	.8	.9
18	50BTB18	1610	3.920	3.599	1	1/8	2 <sup>25/32</sup>	B	.9	.9
19	50BTB19	1610	4.120	3.797	1	1/8	3	B	1.3	.9
20	50BTB20	1610	4.321	3.995	1	1/8	3/4	B	1.6	.9
21	50BTB21	1610	4.522	4.193	1	1/8	3	B	1.5	.9
22	50BTB22	1610	4.722	4.392	1	1/8	3	B	1.6	.9
23	50BTB23	2012	4.922	4.590	2	1/4	3 <sup>3/16</sup>	B	2.0	1.7
24	50BTB24	2012	5.122	4.788	2	1/4	3 <sup>3/16</sup>	B	2.2	1.7
25	50BTB25	2012	5.322	4.987	2	1/4	3 <sup>3/16</sup>	B	2.4	1.7
26	50BTB26	2012	5.522	5.185	2	1/4	3 <sup>3/16</sup>	B	2.5	1.7
27	50BTB27	2012	5.723	5.384	2	1/4	3 <sup>3/16</sup>	B	2.6	1.7
28	50BTB28	2012	5.922	5.582	2	1/4	3 <sup>3/16</sup>	B	2.8	1.7
30	50BTB30	2012	6.321	5.979	2	1/4	3 <sup>3/16</sup>	B	3.2	1.7
32	50BTB32	2012	6.721	6.376	2	1/4	3 <sup>3/16</sup>	B	3.6	1.7
35	50BTB35	2012	7.319	6.972	2	1/4	3 <sup>3/16</sup>	B	4.2	1.7
36	50BTB36	2012	7.519	7.171	2	1/4	3 <sup>3/16</sup>	B	4.3	1.7
40	50BTB40	2012	8.316	7.966	2	1/4	3 <sup>3/16</sup>	B	5.2	1.7
42	50BTB42	2012	8.715	8.363	2	1/4	3 <sup>3/16</sup>	B	5.9	1.7
45	50BTB45	2012	9.313	8.960	2	1/4	3 <sup>3/16</sup>	B	6.5	1.7
48	50BTB48	2012	9.911	9.556	2	1/4	3 <sup>3/16</sup>	B	7.3	1.7
54	50BTB54	2012	11.106	10.749	2	1/4	3 <sup>3/16</sup>	B	9.0	1.7
60	50BTB60	2012	12.301	11.942	2	1/4	3 <sup>3/16</sup>	B	10.8	1.7
70	50BTB70	2517	14.292	13.931	2	1/2	4	B	14.0	3.5
72	50BTB72	2517	14.690	14.329	2	1/2	4	B	15.5	3.5
80	50BTB80	2517	16.282	15.920	2	1/2	4	B	19.5	3.5
84	50BTB84	2517	17.079	16.715	2	1/2	4	B	22.5	3.5
96	50BTB96	2517	19.466	19.102	2	1/2	4	B	29.0	3.5
112	50BTB112	2517	22.651	22.285	2	1/2	4	B	38.7	3.5

★ Has recessed groove in hub for chain clearance.

# No.50-2 | Taper bore Sprockets

- Pitch  $5/8''$
- Roller  $\phi$  0.400"
- Tooth width b1 0.332"
- Tooth width B2 1.045"

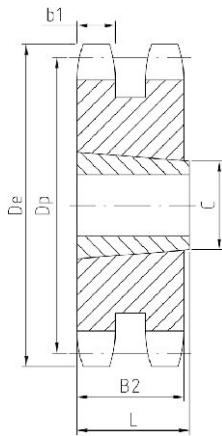

TYPE A

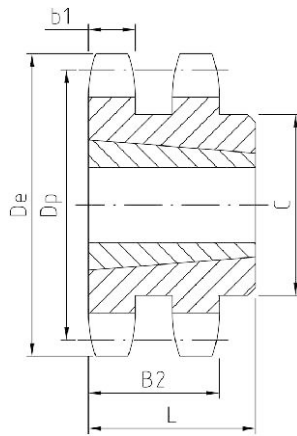

TYPE B

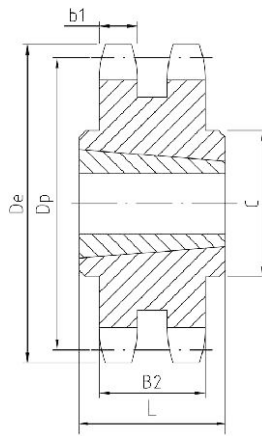

TYPE C

## Double-Taper Bushed

No. Teeth	Part Number	Bushing	De	Dp	Max. Bore	L	C	Type	Weight(Approx.)	
									Rim Only	Bushing Only
14	D50ATB14H	1008	3.113	2.809	1	7/8		A	.8	.3
15	D50ATB15H	1210	3.315	3.006	1 1/4	1		A	.9	.6
16	D50ATB16H	1210	3.517	3.204	1 1/4	1		A	1.1	.6
17	D50ATB17H	1610	3.719	3.410	1 7/8	1		A	1.1	.6
18	D50ATB18H	1610	3.920	3.599	1 7/8	1		A	1.3	.9
19	D50ATB19H	1610	4.120	3.797	1 7/8	1		A	1.6	.9
20	D50BTB20H	2012	4.321	3.995	2	1 1/4	3/4	B	1.5	1.7
21	D50BTB21H	2012	4.522	4.193	2	1 1/4	3/2	B	1.9	1.7
25	D50BTB25H	2012	5.322	4.987	2	1 1/4	4 7/32	B	3.8	1.7
30	D50BTB30	2517	6.321	5.979	2 1/2	1 3/4	5 7/32	B	7.5	3.5
36	D50CTB36	2517	7.519	7.171	2 1/2	1 3/4	4 1/4	C	9.4	3.5
42	D50CTB42	2517	8.715	8.363	2 1/2	1 3/4	4 1/4	C	13.4	3.5
48	D50CTB48	2517	9.911	9.556	2 1/2	1 3/4	4 1/4	C	18.6	3.5
52	D50CTB52	2517	10.707	10.351	2 1/2	1 3/4	4 7/8	C	22.2	3.5
60	D50CTB60	2517	12.301	11.942	2 1/2	1 3/4	4 7/8	C	30.3	3.5
68	D50CTB68	2517	13.893	13.533	2 1/2	1 3/4	4 7/8	C	39.4	3.5
76	D50CTB76	2517	15.486	15.124	2 1/2	1 3/4	4 7/8	C	41.2	3.5
84	D50CTB84	2517	17.079	16.715	2 1/2	1 3/4	4 7/8	C	45.3	3.5
95	D50CTB95	2517	19.267	18.903	2 1/2	1 3/4	4 7/8	C	58.8	3.5
102	D50CTB102	2517	20.661	20.295	2 1/2	1 3/4	4 7/8	C	67.1	3.5



NOTE: Double 50 stock sprockets with 25 teeth or less have hardened teeth.

# No.60 | Taper bore Sprockets

- Pitch  $\frac{3}{4}$ "
- Roller  $\phi$  0.468"
- Tooth width B1 0.459"

## Single-Taper Bushed with Hardened Teeth

No. Teeth	Part Number
11	60BTB11H
12	60BTB12H
13	60BTB13H
14	60BTB14H
15	60BTB15H
16	60BTB16H
17	60BTB17H
18	60BTB18H
19	60BTB19H
20	60BTB20H
21	60BTB21H
22	60BTB22H
23	60BTB23H
24	60BTB24H
25	60BTB25H
26	60BTB26H
27	60BTB27H
28	60BTB28H
30	60BTB30H

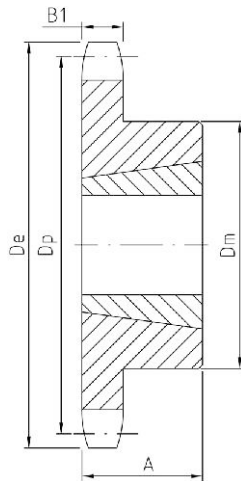

TYPE B

## Single-Taper Bushed

No. Teeth	Part Number	Bushings	De	Dp	Max. Bore	L	C	Type	Weight(Approx.)	
									Rim Only	Bushing Only
11	60BTB11	1008	3.004	2.662	1	$\frac{7}{8}$	$\frac{1^9}{16}$	B	.6	.3
12	60BTB12	1008	3.249	2.898	1	$\frac{7}{8}$	$\frac{1^9}{16}$	B	.8	.3
13	60BTB13	1210	3.493	3.134	$\frac{1}{4}$	1	$\frac{1^9}{32}$ ★	B	.8	.6
14	60BTB14	1210	3.736	3.371	$\frac{1}{4}$	1	$\frac{1^9}{32}$	B	1.0	.6
15	60BTB15	1610	3.979	3.607	$\frac{1^9}{8}$	1	$\frac{2^9}{32}$	B	1.0	.9
16	60BTB16	1610	4.221	3.844	$\frac{1^9}{8}$	1	3	B	1.4	.9
17	60BTB17	1610	4.462	4.082	$\frac{1^9}{8}$	1	$\frac{3}{4}$	B	1.8	.9
18	60BTB18	1610	4.704	4.319	$\frac{1^9}{8}$	1	$\frac{3}{4}$	B	1.9	.9
19	60BTB19	1610	4.945	4.557	$\frac{1^9}{8}$	1	$\frac{3}{4}$	B	2.2	.9
20	60BTB20	2012	5.185	4.794	2	$\frac{1}{4}$	$\frac{3^9}{16}$	B	2.2	1.7
21	60BTB21	2012	5.426	5.032	2	$\frac{1}{4}$	$\frac{3^9}{16}$	B	2.5	1.7
22	60BTB22	2012	5.666	5.270	2	$\frac{1}{4}$	$\frac{3^9}{16}$	B	2.8	1.7
23	60BTB23	2012	5.907	5.508	2	$\frac{1}{4}$	$\frac{3^9}{16}$	B	3.1	1.7
24	60BTB24	2012	6.147	5.746	2	$\frac{1}{4}$	$\frac{3^9}{16}$	B	3.4	1.7
25	60BTB25	2012	6.387	5.984	2	$\frac{1}{4}$	$\frac{3^9}{16}$	B	3.7	1.7
26	60BTB26	2012	6.627	6.222	2	$\frac{1}{4}$	$\frac{3^9}{16}$	B	4.0	1.7
27	60BTB27	2012	6.867	6.416	2	$\frac{1}{4}$	$\frac{3^9}{16}$	B	4.2	1.7
28	60BTB28	2012	7.107	6.699	2	$\frac{1}{4}$	$\frac{3^9}{16}$	B	4.6	1.7
30	60BTB30	2012	7.586	7.175	2	$\frac{1}{4}$	$\frac{3^9}{16}$	B	5.2	1.7
32	60BTB32	2012	8.065	7.652	2	$\frac{1}{4}$	$\frac{3^9}{16}$	B	5.6	1.7
35	60BTB35	2012	8.783	8.367	2	$\frac{1}{4}$	$\frac{3^9}{16}$	B	6.4	1.7
36	60BTB36	2012	9.022	8.605	2	$\frac{1}{4}$	$\frac{3^9}{16}$	B	6.6	1.7
40	60BTB40	2012	9.980	9.559	2	$\frac{1}{4}$	$\frac{3^9}{16}$	B	8.3	1.7
42	60BTB42	2012	10.458	10.036	2	$\frac{1}{4}$	$\frac{3^9}{16}$	B	10.0	1.7
45	60BTB45	2012	11.175	10.752	2	$\frac{1}{4}$	$\frac{3^9}{16}$	B	11.5	1.7
48	60BTB48	2012	11.893	11.467	2	$\frac{1}{4}$	$\frac{3^9}{16}$	B	13.2	1.7
54	60BTB54	2517	13.327	12.899	$2\frac{1}{2}$	$1\frac{3}{4}$	$\frac{4}{4}$	B	17.1	3.5
60	60BTB60	2517	14.761	14.330	$2\frac{1}{2}$	$1\frac{3}{4}$	$\frac{4}{4}$	B	21.0	3.5
70	60BTB70	2517	17.150	16.717	$2\frac{1}{2}$	$1\frac{3}{4}$	$\frac{4}{4}$	B	27.6	3.5
72	60BTB72	2517	17.628	17.194	$2\frac{1}{2}$	$1\frac{3}{4}$	$\frac{4}{4}$	B	30.0	3.5
80	60BTB80	2517	19.539	19.103	$2\frac{1}{2}$	$1\frac{3}{4}$	$\frac{4}{4}$	B	36.3	3.5
84	60BTB84	2517	20.494	20.058	$2\frac{1}{2}$	$1\frac{3}{4}$	$\frac{4}{4}$	B	40.6	3.5

★ Has recessed groove in hub for chain clearance.

# No.60-2 | Taper bore Sprockets

- Pitch  $\frac{3}{4}$ "
- Roller  $\phi$  0.468"
- Tooth width b1 0.444"
- Tooth width B2 1.341"

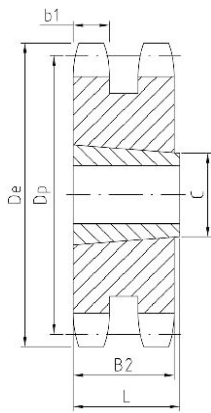

TYPE A

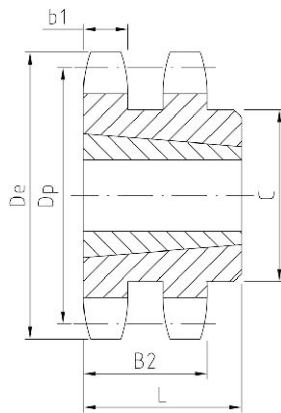

TYPE B

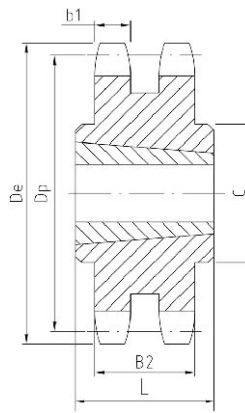

TYPE C

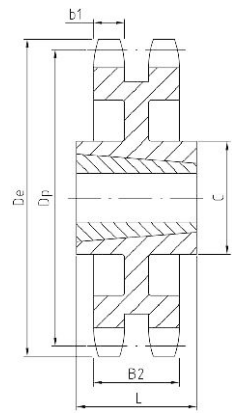

TYPE C1

## Double-Taper Bushed

No. Teeth	Part Number	Bushing	De	Dp	Max. Bore	L	C	Type	Weight(Approx.)	
									Rim Only	Bushing Only
13	D60BTB13H	1215	3.493	3.134	1 $\frac{1}{4}$	1 $\frac{1}{2}$	2 $\frac{1}{4}$	B	1.2	1.6
14	D60BTB14H	1215	3.736	3.371	1 $\frac{1}{4}$	1 $\frac{1}{2}$	2 $\frac{1}{8}$	B	1.6	1.7
15	D60BTB15H	1615	3.979	3.607	1 $\frac{7}{8}$	1 $\frac{1}{2}$	2 $\frac{5}{16}$	B	1.3	1.8
16	D60BTB16H	1615	4.221	3.844	1 $\frac{7}{8}$	1 $\frac{1}{2}$	3	B	2.2	2.3
17	D60BTB17H	1615	4.462	4.082	1 $\frac{7}{8}$	1 $\frac{1}{2}$	3 $\frac{1}{4}$	B	2.5	2.8
18	D60BTB18H	2012	4.704	4.319	2	1 $\frac{1}{4}$		A	3.0	2.4
19	D60BTB19H	2012	4.945	4.557	2	1 $\frac{1}{4}$		A	3.5	2.9
20	D60BTB20H	2517	5.185	4.794	2 $\frac{1}{2}$	1 $\frac{3}{4}$	3 $\frac{5}{8}$	B	4.0	2.9
21	D60BTB21H	2517	5.426	5.032	2 $\frac{1}{2}$	1 $\frac{3}{4}$	4 $\frac{1}{8}$	B	5.0	3.8
25	D60BTB25H	2517	6.387	4.984	2 $\frac{1}{2}$	1 $\frac{3}{4}$	5 $\frac{1}{2}$	B	7.5	7.4
30	D60BTB30	2517	7.586	7.175	2 $\frac{1}{2}$	1 $\frac{3}{4}$	6 $\frac{1}{2}$	B	13.5	13.3
36	D60CTB36	2517	9.022	8.605	2 $\frac{1}{2}$	1 $\frac{3}{4}$	4 $\frac{1}{4}$	C	17.5	17.4
42	D60CTB42	2517	10.458	10.036	2 $\frac{1}{2}$	1 $\frac{3}{4}$	4 $\frac{1}{4}$	C	25.5	25.0
45	D60CTB45	2517	11.176	10.752	2 $\frac{1}{2}$	1 $\frac{3}{4}$	4 $\frac{1}{4}$	C	29.5	29.3
52	D60CTB52	2517	12.849	12.422	2 $\frac{1}{2}$	1 $\frac{3}{4}$	4 $\frac{1}{4}$	C	41.0	40.3
60	D60CTB60	2517	14.761	14.330	2 $\frac{1}{2}$	1 $\frac{3}{4}$	4 $\frac{1}{4}$	C1	32.5	33.5
68	D60CTB68	2517	16.672	16.240	2 $\frac{1}{2}$	1 $\frac{3}{4}$	4 $\frac{1}{4}$	C1	36.5	43.2
76	D60CTB76	3020	18.583	18.149	3	2	5 $\frac{1}{4}$	C1	42.5	47.8
95	D60CTB95	3020	23.121	22.684	3	2	5 $\frac{1}{4}$	C1	48.5	69.8



NOTE: Double 60 stock sprockets with 25 teeth or less have hardened teeth.

# No.80 | Taper bore Sprockets

- Pitch 1"
- Roller  $\phi$  0.625"
- Tooth width B1 0.575"

## Single-Taper Bushed with Hardened Teeth

No. Teeth	Part Number
10	80BTB10H
11	80BTB11H
12	80BTB12H
13	80BTB13H
14	80BTB14H
15	80BTB15H
16	80BTB16H
17	80BTB17H
18	80BTB18H
19	80BTB19H
20	80BTB20H
21	80BTB21H
22	80BTB22H
23	80BTB23H
24	80BTB24H
25	80BTB25H
26	80BTB26H
27	80BTB27H
28	80BTB28H
30	80BTB30H

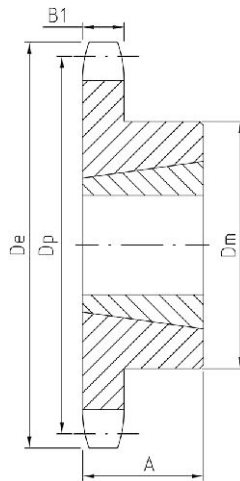

TYPE B



## Single-Taper Bushed

No. Teeth	Part Number	Bushing	De	Dp	Max. Bore	L	C	Type	Weight(Approx.)	
									Rim Only	Bushing Only
10	80BTB10	1215	3.678	3.236	1/4	1/2	2 <sup>3</sup> / <sub>8</sub> ★	B	1.1	.8
11	80BTB11	1215	4.006	3.549	1/4	1/2	2 <sup>3</sup> / <sub>32</sub> ★	B	1.5	.8
12	80BTB12	1615	4.332	3.864	1/8	1/2	3 ★	B	1.8	1.2
13	80BTB13	1615	4.657	4.179	1/8	1/2	3	B	2.3	1.2
14	80BTB14	1615	4.982	4.494	1/8	1/2	3/4	B	2.5	1.2
15	80BTB15	1615	5.305	4.810	1/8	1/2	3/4	B	2.7	1.2
16	80BTB16	2012	5.627	5.126	2	1/4	3/16	B	2.8	1.7
17	80BTB17	2012	5.950	5.442	2	1/4	3/16	B	3.1	1.7
18	80BTB18	2012	6.271	5.759	2	1/4	3/16	B	2.6	1.7
19	80BTB19	2012	6.593	6.076	2	1/4	3/16	B	4.1	1.7
20	80BTB20	2517	6.914	6.392	2 1/2	1 3/4	4/4	B	5.5	1.7
21	80BTB21	2517	7.235	6.710	2 1/2	1 3/4	4/4	B	6.0	3.5
22	80BTB22	2517	7.555	7.027	2 1/2	1 3/4	4/4	B	6.5	3.5
23	80BTB23	2517	7.875	7.344	2 1/2	1 3/4	4/4	B	7.0	3.5
24	80BTB24	2517	8.196	7.661	2 1/2	1 3/4	4/4	B	7.5	3.5
25	80BTB25	2517	8.516	7.979	2 1/2	1 3/4	4/4	B	8.1	3.5
26	80BTB26	2517	8.836	8.296	2 1/2	1 3/4	4/4	B	8.8	3.5
27	80BTB27	2517	9.156	8.614	2 1/2	1 3/4	4/4	B	9.0	3.5
28	80BTB28	2517	9.475	8.931	2 1/2	1 3/4	4/4	B	9.5	3.5
30	80BTB30	2517	10.114	9.567	2 1/2	1 3/4	4/4	B	11.5	3.5
32	80BTB32	2517	10.753	10.202	2 1/2	1 3/4	4/4	B	12.0	3.5
35	80BTB35	2517	11.711	11.156	2 1/2	1 3/4	4/4	B	15.2	3.5
36	80BTB36	2517	12.030	11.474	2 1/2	1 3/4	4/4	B	17.0	3.5
40	80BTB40	2517	13.306	12.746	2 1/2	1 3/4	4/4	B	21.0	3.5
45	80BTB45	2517	14.901	14.336	2 1/2	1 3/4	4/4	B	26.5	3.5
48	80BTB48	2517	15.857	15.290	2 1/2	1 3/4	4/4	B	29.5	3.5
54	80BTB54	2517	17.769	17.198	2 1/2	1 3/4	4/4	B	38.5	3.5
60	80BTB60	2517	19.681	19.107	2 1/2	1 3/4	4/4	B	45.0	3.5
70	80BTB70	3020	22.867	22.289	3	2	5/4	B	52.3	6.5
80	80BTB80	3020	26.052	25.471	3	2	5/4	B	69.2	6.5

★ Has recessed groove in hub for chain clearance.

# No.80-2 | Taper bore Sprockets

- Pitch **1"**       Roller  $\phi$  **0.625"**
- Tooth width **b1 0.557"**       Tooth width **B2 1.710"**

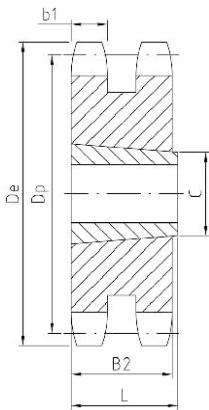

**TYPE A**

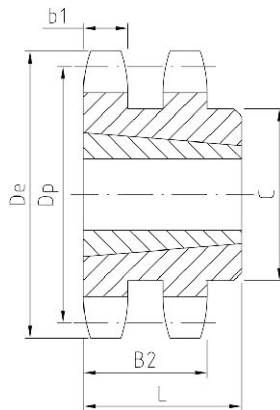

**TYPE B**

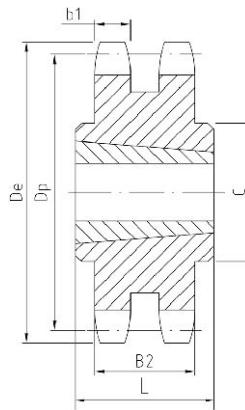

**TYPE C**

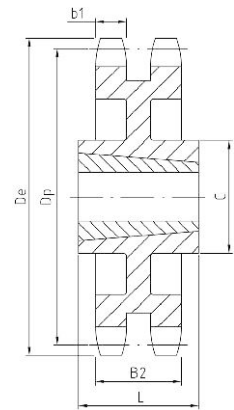

**TYPE C1**

## Double-Taper Bushed

No. Teeth	Part Number	Bushing	De	Dp	Max. Bore	L	C	Type	Weight(Approx.)	
									Rim Only	Bushing Only
13	D80ATB13H	1615	4.657	4.179	1 <sup>7</sup> / <sub>8</sub>	1 <sup>1</sup> / <sub>2</sub>		A	3.4	1.2
14	D80ATB14H	2012	4.982	4.494	2	1 <sup>1</sup> / <sub>4</sub>		A	3.5	1.7
15	D80ATB15H	2012	5.305	4.810	2	1 <sup>1</sup> / <sub>4</sub>		A	4.3	1.7
16	D80ATB16H	2517	5.627	5.126	2 <sup>1</sup> / <sub>2</sub>	1 <sup>3</sup> / <sub>4</sub>	3 <sup>3</sup> / <sub>8</sub>	A	3.8	3.5
17	D80ATB17H	2517	5.950	5.442	2 <sup>1</sup> / <sub>2</sub>	1 <sup>3</sup> / <sub>4</sub>	3 <sup>3</sup> / <sub>8</sub>	A	5.1	3.5
18	D80ATB18H	2517	6.271	5.759	2 <sup>1</sup> / <sub>2</sub>	1 <sup>3</sup> / <sub>4</sub>	3 <sup>3</sup> / <sub>8</sub>	A	6.4	3.5
19	D80BTB19H	3020	6.593	6.076	3	2	5	B	5.6	6.5
20	D80BTB20H	3020	6.914	6.392	3	2	5 <sup>1</sup> / <sub>4</sub>	B	7.1	6.5
21	D80BTB21H	3020	7.235	6.710	3	2	5 <sup>5</sup> / <sub>16</sub>	B	8.9	6.5
25	D80BTB25H	3020	8.516	7.979	3	2	6 <sup>7</sup> / <sub>8</sub>	B	16.5	6.5
30	D80CTB30	3020	10.114	9.567	3	2	5 <sup>1</sup> / <sub>4</sub>	C	25.1	6.5
36	D80CTB36	3020	12.030	11.474	3	2	5 <sup>1</sup> / <sub>4</sub>	C	39.4	6.5
42	D80CTB42	3020	13.944	13.392	3	2	5 <sup>1</sup> / <sub>4</sub>	C	36.4	6.5
45	D80CTB45	3020	14.901	14.336	3	2	5 <sup>1</sup> / <sub>4</sub>	C1	41.4	6.5
52	D80CTB52	3020	17.132	16.562	3	2	5 <sup>1</sup> / <sub>4</sub>	C1	56.2	6.5
60	D80CTB60	3020	19.681	19.107	3	2	5 <sup>1</sup> / <sub>4</sub>	C1	66.3	6.5
68	D80CTB68	3020	22.230	21.653	3	2	5 <sup>1</sup> / <sub>4</sub>	C1	72.0	6.5
76	D80CTB76	3020	24.778	24.198	3	2	5 <sup>1</sup> / <sub>4</sub>	C1	89.1	6.5
95	D80CTB95	3020	30.828	30.245	3	2	5 <sup>1</sup> / <sub>4</sub>	C1	112	6.5



# No.100 | Taper bore Sprockets

- Pitch  $1\frac{1}{4}''$   Roller  $\phi$  0.750''
- Tooth width B1 0.692''

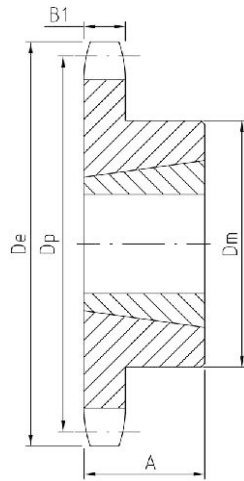

TYPE B

## Single-Taper Bushed

No. Teeth	Part Number	Bushing	De	Dp	Max. Bore	L	C	Type	Weight(Approx.)	
									Rim Only	Bushing Only
11	100BTB11	1615	5.007	4.437	1 <sup>7</sup> / <sub>8</sub>	1 <sup>1</sup> / <sub>2</sub>	3	B	2.7	1.2
12	100BTB12	1615	5.415	4.830	1 <sup>7</sup> / <sub>8</sub>	1 <sup>1</sup> / <sub>2</sub>	3 <sup>3</sup> / <sub>4</sub>	B	3.5	1.2
13	100BTB13	2012	5.821	5.223	2	1 <sup>1</sup> / <sub>4</sub>	3 <sup>9</sup> / <sub>16</sub>	B	3.6	1.7
14	100BTB14	2012	6.227	5.617	2	1 <sup>1</sup> / <sub>4</sub>	3 <sup>9</sup> / <sub>16</sub>	B	3.9	1.7
15	100BTB15	2517	6.631	6.012	2 <sup>1</sup> / <sub>2</sub>	1 <sup>3</sup> / <sub>4</sub>	4 <sup>1</sup> / <sub>4</sub>	B	5.0	3.5
16	100BTB16	2517	7.034	6.407	2 <sup>1</sup> / <sub>2</sub>	1 <sup>3</sup> / <sub>4</sub>	4 <sup>1</sup> / <sub>2</sub>	B	6.4	3.5
17	100BTB17	2517	7.437	6.803	2 <sup>1</sup> / <sub>2</sub>	1 <sup>3</sup> / <sub>4</sub>	4 <sup>1</sup> / <sub>2</sub>	B	7.1	3.5
18	100BTB18	2517	7.839	7.198	2 <sup>1</sup> / <sub>2</sub>	1 <sup>3</sup> / <sub>4</sub>	4 <sup>1</sup> / <sub>2</sub>	B	7.8	3.5
19	100BTB19	2517	8.241	7.594	2 <sup>1</sup> / <sub>2</sub>	1 <sup>3</sup> / <sub>4</sub>	4 <sup>1</sup> / <sub>2</sub>	B	8.7	3.5
20	100BTB20	2517	8.642	7.991	2 <sup>1</sup> / <sub>2</sub>	1 <sup>3</sup> / <sub>4</sub>	4 <sup>1</sup> / <sub>2</sub>	B	9.6	3.5
21	100BTB21	2517	9.043	8.387	2 <sup>1</sup> / <sub>2</sub>	1 <sup>3</sup> / <sub>4</sub>	4 <sup>1</sup> / <sub>2</sub>	B	10.6	3.5
22	100BTB22	2517	9.444	8.783	2 <sup>1</sup> / <sub>2</sub>	1 <sup>3</sup> / <sub>4</sub>	4 <sup>1</sup> / <sub>2</sub>	B	11.0	3.5
24	100BTB24	2517	10.245	9.577	2 <sup>1</sup> / <sub>2</sub>	1 <sup>3</sup> / <sub>4</sub>	4 <sup>1</sup> / <sub>2</sub>	B	13.0	3.5
26	100BTB26	2517	11.045	10.370	2 <sup>1</sup> / <sub>2</sub>	1 <sup>3</sup> / <sub>4</sub>	4 <sup>1</sup> / <sub>2</sub>	B	15.0	3.5
28	100BTB28	3020	11.844	11.164	3	2	5 <sup>1</sup> / <sub>4</sub>	B	16.5	6.5
30	100BTB30	3020	12.643	11.958	3	2	5 <sup>1</sup> / <sub>4</sub>	B	22.0	6.5
32	100BTB32	3020	13.442	12.753	3	2	5 <sup>1</sup> / <sub>4</sub>	B	23.0	6.5
35	100BTB35	3020	14.639	13.945	3	2	5 <sup>1</sup> / <sub>4</sub>	B	28.0	6.5
36	100BTB36	3020	15.038	14.342	3	2	5 <sup>1</sup> / <sub>4</sub>	B	31.0	6.5
40	100BTB40	3020	16.633	15.932	3	2	5 <sup>1</sup> / <sub>4</sub>	B	37.0	6.5
45	100BTB45	3020	18.626	17.919	3	2	5 <sup>1</sup> / <sub>4</sub>	B	46.0	6.5
48	100BTB48	3020	19.821	19.112	3	2	5 <sup>1</sup> / <sub>4</sub>	B	53.0	6.5
54	100BTB54	3020	22.212	21.498	3	2	5 <sup>1</sup> / <sub>4</sub>	B	62.0	6.5
60	100BTB60	3020	24.601	23.884	3	2	5 <sup>1</sup> / <sub>4</sub>	B	72.0	6.5

# No.120 | Taper bore Sprockets

- Pitch  $1\frac{1}{2}$ "
- Roller  $\phi$  0.875"
- Tooth width B1 0.924"

## Single-Taper Bushed with Hardened Teeth

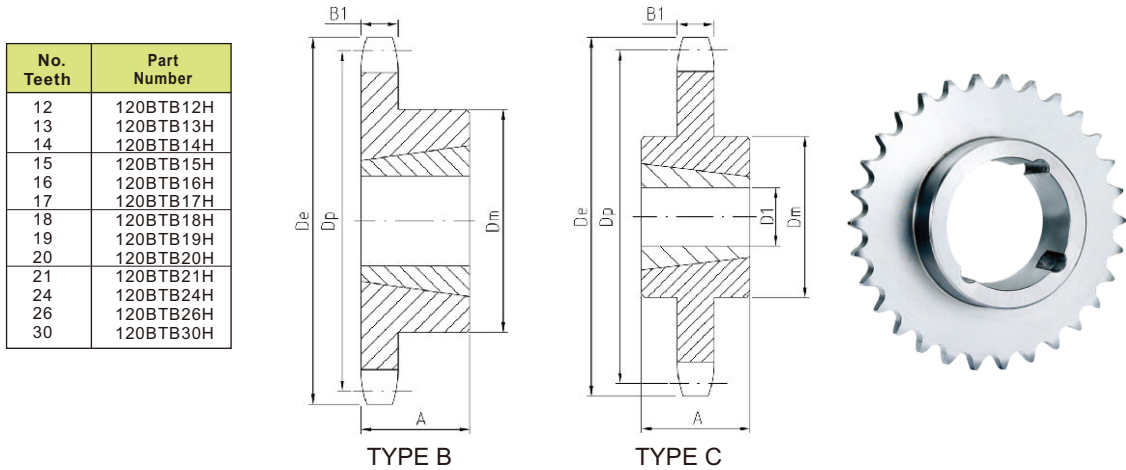

## Single-Taper Bushed

No. Teeth	Part Number	Bushing	De	Dp	Max. Bore	L	C	Type	Weight(Approx.)	
									Rim Only	Bushing Only
12	120BTB12	2012	6.498	5.796	2	1 <sup>1</sup> / <sub>4</sub>	3 <sup>9</sup> / <sub>16</sub>	B	5.5	1.7
13	120BTB13	2517	6.896	6.268	2 <sup>1</sup> / <sub>2</sub>	1 <sup>3</sup> / <sub>4</sub>	4 <sup>1</sup> / <sub>4</sub>	B	6.0	3.5
14	120BTB14	2517	7.472	6.741	2 <sup>1</sup> / <sub>2</sub>	1 <sup>3</sup> / <sub>4</sub>	4 <sup>1</sup> / <sub>4</sub>	B	7.0	3.5
15	120BTB15	2517	7.957	7.215	2 <sup>1</sup> / <sub>2</sub>	1 <sup>3</sup> / <sub>4</sub>	4 <sup>1</sup> / <sub>4</sub>	B	8.0	3.5
16	120BTB16	3020	8.441	7.689	3	2	5 <sup>1</sup> / <sub>4</sub>	B	10.0	6.5
17	120BTB17	3020	8.924	8.163	3	2	5 <sup>1</sup> / <sub>4</sub>	B	11.0	6.5
18	120BTB18	3020	9.407	8.638	3	2	5 <sup>1</sup> / <sub>4</sub>	B	12.0	6.5
19	120BTB19	3020	9.889	9.113	3	2	5 <sup>1</sup> / <sub>4</sub>	B	14.0	6.5
20	120BTB20	3020	10.371	9.588	3	2	5 <sup>1</sup> / <sub>4</sub>	B	15.5	6.5
21	120BTB21	3020	10.851	10.064	3	2	5 <sup>1</sup> / <sub>4</sub>	B	17.5	6.5
24	120BTB24	3020	12.294	11.492	3	2	5 <sup>1</sup> / <sub>4</sub>	B	23.5	6.5
26	120BTB26	3020	13.254	12.444	3	2	5 <sup>1</sup> / <sub>4</sub>	B	28.5	6.5
30	120BTB30	3020	15.171	14.351	3	2	5 <sup>1</sup> / <sub>4</sub>	B	33.5	6.5
35	120CTB35	3020	17.566	16.734	3	2	5 <sup>1</sup> / <sub>4</sub>	C	52.5	6.5
45	120CTB45	3020	22.351	21.503	3	3	5 <sup>7</sup> / <sub>8</sub>	C	82.0	9.2
60	120CTB60	3535	29.522	28.661	3 <sup>1</sup> / <sub>2</sub>	3 <sup>1</sup> / <sub>2</sub>	6 <sup>1</sup> / <sub>2</sub>	C	140.0	14.0
70	120CTB70	3535	34.301	33.434	3 <sup>1</sup> / <sub>2</sub>	3 <sup>1</sup> / <sub>2</sub>	6 <sup>1</sup> / <sub>2</sub>	C	175.0	14.0
80	120CTB80	3535	39.078	38.207	3 <sup>1</sup> / <sub>2</sub>	3 <sup>1</sup> / <sub>2</sub>	6 <sup>1</sup> / <sub>2</sub>	C	220.0	14.0

# No.140 | Taper bore Sprockets

- Pitch  $1\frac{3}{4}"$
- Roller  $\phi$  1.000"
- Tooth width b1 0.924"

## Single-Taper Bushed with Hardened Teeth

No. Teeth	Part Number
12	140BTB12H
13	140BTB13H
14	140BTB14H
15	140BTB15H
16	140BTB16H
17	140BTB17H
18	140BTB18H
19	140BTB19H
21	140BTB21H
26	140BTB26H

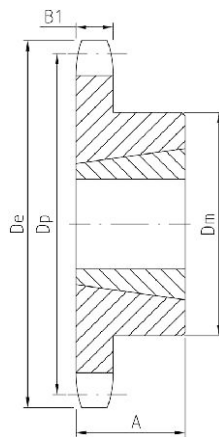

TYPE B

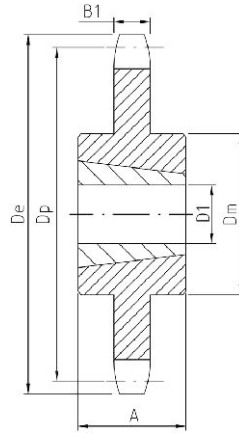

TYPE C



## Single-Taper Bushed

No. Teeth	Part Number	Bushing	De	Dp	Max. Bore	L	C	Type	Weight(Approx.)	
									Rim Only	Bushing Only
12	140BTB12	2517	7.581	6.762	2½	1¼	4¼	B	7.0	3.5
13	140BTB13	3020	8.150	7.313	3	2	5¼	B	8.0	6.5
14	140BTB14	3020	8.718	7.864	3	2	5¼	B	10.0	6.5
15	140BTB15	3020	9.283	8.417	3	2	5¼	B	12.0	6.5
16	140BTB16	3020	9.848	8.970	3	2	5¼	B	14.0	6.5
17	140BTB17	3020	10.411	9.524	3	2	5¼	B	16.0	6.5
18	140BTB18	3020	10.975	10.078	3	2	5¼	B	18.0	6.5
19	140BTB19	3020	11.537	10.632	3	2	5¼	B	20.0	6.5
21	140BTB21	3020	12.660	11.742	3	2	5¼	B	24.0	6.5
26	140BTB26	3020	15.463	14.518	3	2	5¼	B	40.0	6.5
35	140BTB35	3535	20.494	19.523	3½	3½	6¼	C	78.0	14
45	140CTB45	4040	26.076	25.087	4	4	7¼	C	118.0	22
60	140CTB60	4040	34.442	33.438	4	4	7¼	C	188.0	22
70	140CTB70	4040	40.017	39.006	4	4	7¼	C	241.0	22

# No.160 | Taper bore Sprockets

- Pitch 2"
- Roller  $\phi$  1.125"
- Tooth width B1 1.156"

## Single-Taper Bushed with Hardened Teeth

No. Teeth	Part Number
11	160BTB11H
12	160BTB12H
13	160BTB13H
14	160BTB14H
15	160BTB15H
16	160BTB16H
17	160BTB17H
18	160BTB18H
19	160BTB19H
21	160BTB21H
26	160BTB26H

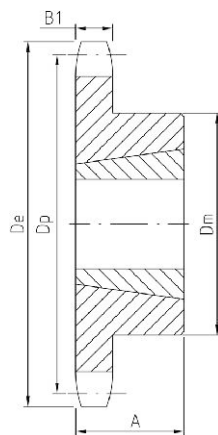

TYPE B

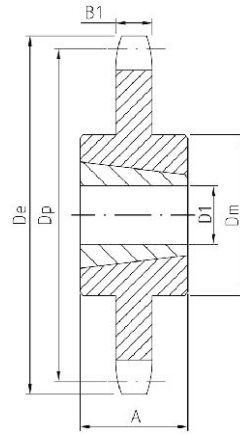

TYPE B



## Single-Taper Bushed

No. Teeth	Part Number	Bushing	De	Dp	Max. Bore	L	C	Type	Weight(Approx.)	
									Rim Only	Bushing Only
11	160BTB11	2517	8.011	7.099	2½	1¾	4¼	B	9.0	3.5
12	160BTB12	3020	8.664	7.727	3	2	5¼	B	11.0	6.5
13	160BTB13	3020	9.314	8.357	3	2	5¼	B	13.0	6.5
14	160BTB14	3020	9.963	8.988	3	2	5¼	B	16.0	6.5
15	160BTB15	3535	10.609	9.620	3½	3½	6½	B	25.0	14.0
16	160BTB16	3535	11.255	10.252	3½	3½	6½	B	28.0	14.0
17	160BTB17	3535	11.899	10.885	3½	3½	6½	B	32.0	14.0
18	160BTB18	3535	12.543	11.518	3½	3½	6½	B	35.0	14.0
19	160BTB19	3535	13.185	12.151	3½	3½	6½	B	39.0	14.0
21	160BTB21	3535	14.470	13.419	3½	3½	6½	B	48.0	14.0
26	160BTB26	3535	17.671	16.593	3½	3½	6½	B	68.0	14.0
35	160CTB35	4040	23.422	22.312	4	4	7¾	C	118	14.0
45	160CTB45	4040	29.802	28.671	4	4	7¾	C	186	22.0
60	160CTB60	4545	39.362	38.215	4½	4½	8¾	C	292	30.0

# No.35

# No.41 | Sprockets with Split Taper Bushings



- Pitch  $3/8''$   Roller  $\phi$   $0.200''$
- Tooth width B1  $0.168''$

### Single-Split Taper Bushed

Part Number	Bushing	Bore Range	De	Dp	No. Teeth	Type	B1	OL	L	P	C	H	Wt. Less Bushing
35G15	G	$3/8 - 1''$	1.99"	1.804"	15	3	.168"	$1\frac{1}{32}$	1"	1"	$5/32$	2"	.3
35G16	G	$3/8 - 1''$	2.10	1.922	16	3	.168	$1\frac{1}{32}$	1	1	$5/32$	2	.3
35G17	G	$3/8 - 1$	2.23	2.041	17	3	.168	$1\frac{1}{32}$	1	1	$5/32$	2	.3
35G18	G	$3/8 - 1$	2.35	2.159	18	3	.168	$1\frac{1}{32}$	1	1	$5/32$	2	.3
35G19	G	$3/8 - 1$	2.47	2.278	19	3	.168	$1\frac{1}{4}$	1	$29/32$	$1/16$	2	.3
35H19	H	$3/8 - 1/2$	2.47	2.278	19	3	.168	$1\frac{1}{2}$	$1\frac{1}{4}$	$1\frac{1}{32}$	$1/16$	$2\frac{1}{2}$	.5
35H20	H	$3/8 - 1/2$	2.59	2.397	20	3	.168	$1\frac{1}{2}$	$1\frac{1}{4}$	$1\frac{1}{32}$	$1/16$	$2\frac{1}{2}$	.5
35H21	H	$3/8 - 1/2$	2.70	2.516	21	3	.168	$1\frac{1}{2}$	$1\frac{1}{4}$	$1\frac{1}{32}$	$1/16$	$2\frac{1}{2}$	.6
35H22	H	$3/8 - 1/2$	2.83	2.635	22	3	.168	$1\frac{1}{2}$	$1\frac{1}{4}$	$1\frac{1}{32}$	$1/16$	$2\frac{1}{2}$	.7
35H23	H	$3/8 - 1/2$	2.95	2.754	23	3	.168	$1\frac{1}{2}$	$1\frac{1}{4}$	$1\frac{1}{32}$	$1/16$	$2\frac{1}{2}$	.7
35H24	H	$3/8 - 1/2$	3.05	2.873	24	3	.168	$1\frac{1}{2}$	$1\frac{1}{4}$	$1\frac{1}{32}$	$1/16$	$2\frac{1}{2}$	.8
35H25	H	$3/8 - 1/2$	3.19	2.992	25	3	.168	$1\frac{1}{2}$	$1\frac{1}{4}$	$1\frac{1}{32}$	$1/16$	$2\frac{1}{2}$	.8
35H26	H	$3/8 - 1/2$	3.31	3.111	26	3	.168	$1\frac{1}{2}$	$1\frac{1}{4}$	$1\frac{1}{32}$	$1/16$	$2\frac{1}{2}$	.8
35H28	H	$3/8 - 1/2$	3.55	3.349	28	3	.168	$1\frac{1}{2}$	$1\frac{1}{4}$	$1\frac{1}{32}$	$1/16$	$2\frac{1}{2}$	.9
35H30	H	$3/8 - 1/2$	3.79	3.588	30	3	.168	$1\frac{1}{2}$	$1\frac{1}{4}$	$1\frac{1}{32}$	$1/16$	$2\frac{1}{2}$	.9
35H32	H	$3/8 - 1/2$	4.03	3.826	32	3	.168	$1\frac{1}{2}$	$1\frac{1}{4}$	$1\frac{1}{32}$	$1/16$	$2\frac{1}{2}$	.9
35H35	H	$3/8 - 1/2$	4.39	4.183	35	3	.168	$1\frac{1}{2}$	$1\frac{1}{4}$	$1\frac{1}{32}$	$1/16$	$2\frac{1}{2}$	1.0
35H36	H	$3/8 - 1/2$	4.51	4.303	36	3	.168	$1\frac{1}{2}$	$1\frac{1}{4}$	$1\frac{1}{32}$	$1/16$	$2\frac{1}{2}$	1.0
35H40	H	$3/8 - 1/2$	4.99	4.780	40	3	.168	$1\frac{1}{2}$	$1\frac{1}{4}$	$1\frac{1}{32}$	$1/16$	$2\frac{1}{2}$	1.2
35H42	H	$3/8 - 1/2$	5.23	5.018	42	3	.168	$1\frac{1}{2}$	$1\frac{1}{4}$	$1\frac{1}{32}$	$1/16$	$2\frac{1}{2}$	1.2
35H45	H	$3/8 - 1/2$	5.59	5.379	45	3	.168	$1\frac{1}{2}$	$1\frac{1}{4}$	$1\frac{1}{32}$	$1/16$	$2\frac{1}{2}$	1.4
35H48	H	$3/8 - 1/2$	5.95	5.734	48	3	.168	$1\frac{1}{2}$	$1\frac{1}{4}$	$1\frac{1}{32}$	$1/16$	$2\frac{1}{2}$	1.5
35H54	H	$3/8 - 1/2$	6.66	6.449	54	3	.168	$1\frac{1}{2}$	$1\frac{1}{4}$	$1\frac{1}{32}$	$1/16$	$2\frac{1}{2}$	1.8
35H60	H	$3/8 - 1/2$	7.38	7.165	60	3	.168	$1\frac{1}{2}$	$1\frac{1}{4}$	$1\frac{1}{32}$	$1/16$	$2\frac{1}{2}$	2.3
35H70	H	$3/8 - 1/2$	8.58	8.358	70	3	.168	$1\frac{1}{2}$	$1\frac{1}{4}$	$1\frac{1}{32}$	$1/16$	$2\frac{1}{2}$	2.8
35H72	H	$3/8 - 1/2$	8.81	8.597	72	3	.168	$1\frac{1}{2}$	$1\frac{1}{4}$	$1\frac{1}{32}$	$1/16$	$2\frac{1}{2}$	3.0
35H80	H	$3/8 - 1/2$	9.77	9.552	80	3	.168	$1\frac{1}{2}$	$1\frac{1}{4}$	$1\frac{1}{32}$	$1/16$	$2\frac{1}{2}$	3.8
35H84	H	$3/8 - 1/2$	10.25	10.029	84	3	.168	$1\frac{1}{2}$	$1\frac{1}{4}$	$1\frac{1}{32}$	$1/16$	$2\frac{1}{2}$	4.0
35H96	H	$3/8 - 1/2$	11.68	11.461	96	3	.168	$1\frac{1}{2}$	$1\frac{1}{4}$	$1\frac{1}{32}$	$1/16$	$2\frac{1}{2}$	5.3
35H112	H	$3/8 - 1/2$	13.59	13.371	112	3	.168	$1\frac{1}{2}$	$1\frac{1}{4}$	$1\frac{1}{32}$	$1/16$	$2\frac{1}{2}$	6.8

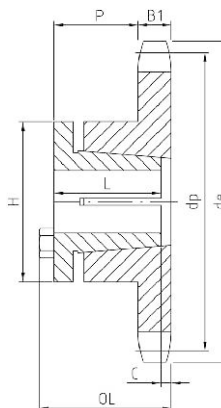

TYPE 3

- Pitch  $1/2''$   Roller  $\phi$   $0.306''$
- Tooth width B1  $0.227''$

### Single-Split Taper Bushed

Part Number	Bushing	Bore Range	De	Dp	Type	No. Teeth	B1	OL	L	P	H	Wt. Less Bushing
41G12	GG	$3/8 - 1''$	2.17"	1.932"	3	12	.227"	$1\frac{7}{16}$	$1\frac{7}{16}$	$1\frac{1}{32}$	2"	.3
41G14	GG	$3/8 - 1$	2.49	2.247	3	14	.227	$1\frac{7}{16}$	$1\frac{7}{16}$	$1\frac{1}{32}$	2	.4
41H15	H	$3/8 - 1/2$	2.65	2.405	3	15	.227	$1\frac{1}{2}$	$1\frac{1}{4}$	$1\frac{1}{32}$	$2\frac{1}{2}$	.5
41H16	H	$3/8 - 1/2$	2.80	2.653	3	16	.227	$1\frac{1}{2}$	$1\frac{1}{4}$	$1\frac{1}{32}$	$2\frac{1}{2}$	.5
41H17	H	$3/8 - 1/2$	2.96	2.721	3	17	.227	$1\frac{1}{2}$	$1\frac{1}{4}$	$1\frac{1}{32}$	$2\frac{1}{2}$	.6
41H18	H	$3/8 - 1/2$	3.14	2.897	3	18	.227	$1\frac{1}{2}$	$1\frac{1}{4}$	$1\frac{1}{32}$	$2\frac{1}{2}$	.7
41H19	H	$3/8 - 1/2$	3.30	3.038	3	19	.227	$1\frac{1}{2}$	$1\frac{1}{4}$	$1\frac{1}{32}$	$2\frac{1}{2}$	.8
41H20	H	$3/8 - 1/2$	3.45	3.196	3	20	.227	$1\frac{1}{2}$	$1\frac{1}{4}$	$1\frac{1}{32}$	$2\frac{1}{2}$	.8
41H21	H	$3/8 - 1/2$	3.62	3.355	3	21	.227	$1\frac{1}{2}$	$1\frac{1}{4}$	$1\frac{1}{32}$	$2\frac{1}{2}$	.9
41H22	H	$3/8 - 1/2$	3.75	3.513	3	22	.227	$1\frac{1}{2}$	$1\frac{1}{4}$	$1\frac{1}{32}$	$2\frac{1}{2}$	.9
41H23	H	$3/8 - 1/2$	3.94	3.672	3	23	.227	$1\frac{1}{2}$	$1\frac{1}{4}$	$1\frac{1}{32}$	$2\frac{1}{2}$	1.0
41H24	H	$3/8 - 1/2$	4.10	3.813	3	24	.227	$1\frac{1}{2}$	$1\frac{1}{4}$	$1\frac{1}{32}$	$2\frac{1}{2}$	1.1
41H25	H	$3/8 - 1/2$	4.26	3.989	3	25	.227	$1\frac{1}{2}$	$1\frac{1}{4}$	$1\frac{1}{32}$	$2\frac{1}{2}$	1.1
41H26	H	$3/8 - 1/2$	4.42	4.158	3	26	.227	$1\frac{1}{2}$	$1\frac{1}{4}$	$1\frac{1}{32}$	$2\frac{1}{2}$	1.1
41H27	H	$3/8 - 1/2$	4.58	4.307	3	27	.227	$1\frac{1}{2}$	$1\frac{1}{4}$	$1\frac{1}{32}$	$2\frac{1}{2}$	1.1
41H28	H	$3/8 - 1/2$	4.70	4.466	3	28	.227	$1\frac{1}{2}$	$1\frac{1}{4}$	$1\frac{1}{32}$	$2\frac{1}{2}$	1.2
41H30	H	$3/8 - 1/2$	5.06	4.783	3	30	.227	$1\frac{1}{2}$	$1\frac{1}{4}$	$1\frac{1}{32}$	$2\frac{1}{2}$	1.3
41H32	H	$3/8 - 1/2$	5.38	5.101	3	32	.227	$1\frac{1}{2}$	$1\frac{1}{4}$	$1\frac{1}{32}$	$2\frac{1}{2}$	1.5
41H35	H	$3/8 - 1/2$	5.86	5.578	3	35	.227	$1\frac{1}{2}$	$1\frac{1}{4}$	$1\frac{1}{32}$	$2\frac{1}{2}$	1.8
41P36	P1	$1/2 - 1\frac{1}{4}$	6.02	5.757	4	36	.227	$2\frac{3}{16}$	$1\frac{15}{16}$	$1\frac{1}{32}$	3	2.5
41P40	P1	$1/2 - 1\frac{3}{4}$	6.55	6.373	4	40	.227	$2\frac{3}{16}$	$1\frac{15}{16}$	$1\frac{1}{32}$	3	3.0
41P42	P1	$1/2 - 1\frac{3}{4}$	6.97	6.691	4	42	.227	$2\frac{3}{16}$	$1\frac{15}{16}$	$1\frac{1}{32}$	3	3.1
41P45	P1	$1/2 - 1\frac{3}{4}$	7.45	7.168	4	45	.227	$2\frac{3}{16}$	$1\frac{15}{16}$	$1\frac{1}{32}$	3	3.5
41P48	P1	$1/2 - 1\frac{3}{4}$	7.93	7.645	4	48	.227	$2\frac{3}{16}$	$1\frac{15}{16}$	$1\frac{1}{32}$	3	4.0
41P54	P1	$1/2 - 1\frac{3}{4}$	8.89	8.599	4	54	.227	$2\frac{3}{16}$	$1\frac{15}{16}$	$1\frac{1}{32}$	3	4.6
41P60	P1	$1/2 - 1\frac{3}{4}$	9.84	9.554	4	60	.227	$2\frac{3}{16}$	$1\frac{15}{16}$	$1\frac{1}{32}$	3	5.5
41P70	P1	$1/2 - 1\frac{3}{4}$	11.43	11.145	4	70	.227	$2\frac{3}{16}$	$1\frac{15}{16}$	$1\frac{1}{32}$	3	7.0
41P72	P1	$1/2 - 1\frac{3}{4}$	11.75	11.463	4	72	.227	$2\frac{3}{16}$	$1\frac{15}{16}$	$1\frac{1}{32}$	3	7.9
41P80	P1	$1/2 - 1\frac{3}{4}$	13.03	12.736	4	80	.227	$2\frac{3}{16}$	$1\frac{15}{16}$	$1\frac{1}{32}$	3	9.3
41P84	P1	$1/2 - 1\frac{3}{4}$	13.66	13.372	4	84	.227	$2\frac{3}{16}$	$1\frac{15}{16}$	$1\frac{1}{32}$	3	9.7
41P96	P1	$1/2 - 1\frac{3}{4}$	15.57	15.281	4	96	.227	$2\frac{3}{16}$	$1\frac{15}{16}$	$1\frac{1}{32}$	3	13
41P112	P1	$1/2 - 1\frac{3}{4}$	18.12	17.828	4	112	.227	$2\frac{3}{16}$	$1\frac{15}{16}$	$1\frac{1}{32}$	3	18

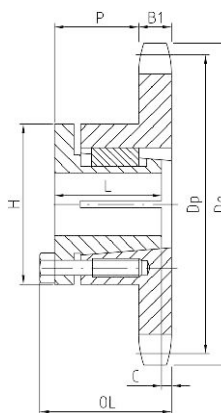

TYPE 4

Sprockets



**GOODWILL**

# No.40 | Sprockets with Split Taper Bushings

- Pitch  $1\frac{1}{2}''$
- Roller  $\phi$   $0.312''$
- Tooth width B1  $0.284''$

## Single-Split Taper Bushed

Part Number	Bushing	Bore Range	De	Dp	No. Teeth	Type	B1	OL	L	P	C	H	Wt. Less Bushing
H40G12	G	$\frac{3}{8}$ - 1"	2.17"	1.932"	12	3	.284"	$1\frac{1}{2}''$	1"	$1\frac{1}{32}''$	$\frac{5}{16}''$	2"	.3
H40G13	G	$\frac{3}{8}$ - 1	2.30	2.089	13	3	.284	$1\frac{1}{2}''$	1"	$1\frac{1}{32}''$	$\frac{5}{16}''$	2	.4
H40G14	G	$\frac{3}{8}$ - 1	2.49	2.247	14	3	.284	$1\frac{1}{2}''$	1"	$1\frac{1}{32}''$	$\frac{5}{16}''$	2	.4
H40G15	H	$\frac{3}{8}$ - $1\frac{1}{2}$	2.65	2.405	15	3	.284	$1\frac{19}{32}''$	$1\frac{1}{4}''$	$1\frac{1}{8}''$	$\frac{5}{32}''$	$2\frac{1}{2}''$	.5
H40G16	H	$\frac{3}{8}$ - $1\frac{1}{2}$	2.80	2.563	16	3	.284	$1\frac{19}{32}''$	$1\frac{1}{4}''$	$1\frac{1}{8}''$	$\frac{5}{32}''$	$2\frac{1}{2}''$	.6
H40H17	H	$\frac{3}{8}$ - $1\frac{1}{2}$	2.96	2.721	17	3	.284	$1\frac{1}{2}''$	$1\frac{1}{4}''$	$1\frac{1}{32}''$	$\frac{1}{16}''$	$2\frac{1}{2}''$	.6
H40H18	H	$\frac{3}{8}$ - $1\frac{1}{2}$	3.14	2.879	18	3	.284	$1\frac{1}{2}''$	$1\frac{1}{4}''$	$1\frac{1}{32}''$	$\frac{1}{16}''$	$2\frac{1}{2}''$	.6
H40P18	P1	$\frac{1}{2}$ - $1\frac{3}{4}$	3.30	3.038	18	4	.284	$2\frac{3}{16}''$	$1\frac{15}{16}''$	$1\frac{21}{32}''$	0	3	1.4
H40H19	H	$\frac{3}{8}$ - $1\frac{1}{2}$	3.14	2.879	18	3	.284	$1\frac{1}{2}''$	$1\frac{1}{4}''$	$1\frac{1}{32}''$	$\frac{1}{16}''$	$2\frac{1}{2}''$	.8
H40P19	P1	$\frac{1}{2}$ - $1\frac{3}{4}$	3.30	3.038	19	4	.284	$2\frac{3}{16}''$	$1\frac{15}{16}''$	$1\frac{21}{32}''$	0	3	1.3
H40H20	H	$\frac{3}{8}$ - $1\frac{1}{2}$	3.45	3.196	20	3	.284	$1\frac{1}{2}''$	$1\frac{1}{4}''$	$1\frac{1}{32}''$	$\frac{1}{16}''$	$2\frac{1}{2}''$	.9
H40P20	P1	$\frac{1}{2}$ - $1\frac{3}{4}$	3.45	3.196	20	4	.284	$2\frac{3}{16}''$	$1\frac{15}{16}''$	$1\frac{21}{32}''$	0	3	.9
H40H21	H	$\frac{3}{8}$ - $1\frac{1}{2}$	3.62	3.355	21	3	.284	$1\frac{1}{2}''$	$1\frac{1}{4}''$	$1\frac{1}{32}''$	$\frac{1}{16}''$	$2\frac{1}{2}''$	.9
H40P21	P1	$\frac{1}{2}$ - $1\frac{3}{4}$	3.62	3.355	21	4	.284	$2\frac{3}{16}''$	$1\frac{15}{16}''$	$1\frac{21}{32}''$	0	3	1.5
H40H22	H	$\frac{3}{8}$ - $1\frac{1}{2}$	3.75	3.513	22	3	.284	$1\frac{1}{2}''$	$1\frac{1}{4}''$	$1\frac{1}{32}''$	$\frac{1}{16}''$	$2\frac{1}{2}''$	1.0
H40P22	P1	$\frac{1}{2}$ - $1\frac{3}{4}$	3.75	3.513	22	4	.284	$2\frac{3}{16}''$	$1\frac{15}{16}''$	$1\frac{21}{32}''$	0	3	1.6
H40H23	H	$\frac{3}{8}$ - $1\frac{1}{2}$	3.94	3.672	23	3	.284	$1\frac{1}{2}''$	$1\frac{1}{4}''$	$1\frac{1}{32}''$	$\frac{1}{16}''$	$2\frac{1}{2}''$	1.0
H40P23	P1	$\frac{1}{2}$ - $1\frac{3}{4}$	3.94	3.672	23	4	.284	$2\frac{3}{16}''$	$1\frac{15}{16}''$	$1\frac{21}{32}''$	0	3	1.7
H40H24	H	$\frac{3}{8}$ - $1\frac{1}{2}$	4.10	3.831	24	3	.284	$1\frac{1}{2}''$	$1\frac{1}{4}''$	$1\frac{1}{32}''$	$\frac{1}{16}''$	$2\frac{1}{2}''$	1.1
H40P24	P1	$\frac{1}{2}$ - $1\frac{3}{4}$	4.10	3.831	24	4	.284	$2\frac{3}{16}''$	$1\frac{15}{16}''$	$1\frac{21}{32}''$	0	3	1.8
H40H25	H	$\frac{3}{8}$ - $1\frac{1}{2}$	4.26	3.989	25	3	.284	$1\frac{1}{2}''$	$1\frac{1}{4}''$	$1\frac{1}{32}''$	$\frac{1}{16}''$	$2\frac{1}{2}''$	1.3
H40P25	P1	$\frac{1}{2}$ - $1\frac{3}{4}$	4.26	3.989	25	4	.284	$2\frac{3}{16}''$	$1\frac{15}{16}''$	$1\frac{21}{32}''$	0	3	1.9
H40H26	H	$\frac{3}{8}$ - $1\frac{1}{2}$	4.42	4.148	26	3	.284	$1\frac{1}{2}''$	$1\frac{1}{4}''$	$1\frac{1}{32}''$	$\frac{1}{16}''$	$2\frac{1}{2}''$	1.3
H40P26	P1	$\frac{1}{2}$ - $1\frac{3}{4}$	4.42	4.148	26	4	.284	$2\frac{3}{16}''$	$1\frac{15}{16}''$	$1\frac{21}{32}''$	0	3	1.9
H40H27	H	$\frac{3}{8}$ - $1\frac{1}{2}$	4.58	4.307	27	3	.284	$1\frac{1}{2}''$	$1\frac{1}{4}''$	$1\frac{1}{32}''$	$\frac{1}{16}''$	$2\frac{1}{2}''$	1.4
H40H28	H	$\frac{3}{8}$ - $1\frac{1}{2}$	4.74	4.466	28	3	.284	$1\frac{1}{2}''$	$1\frac{1}{4}''$	$1\frac{1}{32}''$	$\frac{1}{16}''$	$2\frac{1}{2}''$	1.4
H40P28	P1	$\frac{1}{2}$ - $1\frac{3}{4}$	4.74	4.466	28	4	.284	$2\frac{3}{16}''$	$1\frac{15}{16}''$	$1\frac{21}{32}''$	0	3	2.1
H40P29	P1	$\frac{1}{2}$ - $1\frac{3}{4}$	4.90	4.625	29	4	.284	$2\frac{3}{16}''$	$1\frac{15}{16}''$	$1\frac{21}{32}''$	0	3	2.3
H40H30	H	$\frac{3}{8}$ - $1\frac{1}{2}$	5.06	4.783	30	3	.284	$1\frac{1}{2}''$	$1\frac{1}{4}''$	$1\frac{1}{32}''$	$\frac{1}{16}''$	$2\frac{1}{2}''$	1.6
H40P30	P1	$\frac{1}{2}$ - $1\frac{3}{4}$	5.06	4.783	30	4	.284	$2\frac{3}{16}''$	$1\frac{15}{16}''$	$1\frac{21}{32}''$	0	3	2.3
H40H32	H	$\frac{3}{8}$ - $1\frac{1}{2}$	5.38	5.101	32	3	.284	$1\frac{1}{2}''$	$1\frac{1}{4}''$	$1\frac{1}{32}''$	$\frac{1}{16}''$	$2\frac{1}{2}''$	1.8
H40H33	H	$\frac{3}{8}$ - $1\frac{1}{2}$	5.54	5.260	33	3	.284	$1\frac{1}{2}''$	$1\frac{1}{4}''$	$1\frac{1}{32}''$	$\frac{1}{16}''$	$2\frac{1}{2}''$	1.9
H40H35	H	$\frac{3}{8}$ - $1\frac{1}{2}$	5.86	5.578	35	3	.284	$1\frac{1}{2}''$	$1\frac{1}{4}''$	$1\frac{1}{32}''$	$\frac{1}{16}''$	$2\frac{1}{2}''$	2.1
H40H36	H	$\frac{3}{8}$ - $1\frac{1}{2}$	6.02	5.737	36	3	.284	$1\frac{1}{2}''$	$1\frac{1}{4}''$	$1\frac{1}{32}''$	$\frac{1}{16}''$	$2\frac{1}{2}''$	2.3
H40H38	H	$\frac{3}{8}$ - $1\frac{1}{2}$	6.33	6.055	38	3	.284	$1\frac{1}{2}''$	$1\frac{1}{4}''$	$1\frac{1}{32}''$	$\frac{1}{16}''$	$2\frac{1}{2}''$	2.6
H40H40	H	$\frac{3}{8}$ - $1\frac{1}{2}$	6.65	6.373	40	3	.284	$1\frac{1}{2}''$	$1\frac{1}{4}''$	$1\frac{1}{32}''$	$\frac{1}{16}''$	$2\frac{1}{2}''$	2.8
40G12	G	$\frac{3}{8}$ - 1"	2.17"	1.923"	12	3	.284"	$1\frac{1}{2}''$	1"	$1\frac{1}{32}''$	$\frac{5}{16}''$	2"	.3
40G13	G	$\frac{3}{8}$ - 1	2.30	2.089	13	3	.284	$1\frac{1}{2}''$	1"	$1\frac{1}{32}''$	$\frac{5}{16}''$	2	.4
40G14	G	$\frac{3}{8}$ - 1	2.49	2.247	14	3	.284	$1\frac{1}{2}''$	1"	$1\frac{1}{32}''$	$\frac{5}{16}''$	2	.4
40H15	H	$\frac{3}{8}$ - $1\frac{1}{2}$	2.65	2.405	15	3	.284	$1\frac{19}{32}''$	$1\frac{1}{4}''$	$1\frac{1}{8}''$	$\frac{5}{32}''$	$2\frac{1}{2}''$	.5
40G16	G	$\frac{3}{8}$ - $1\frac{1}{2}$	2.80	2.563	16	3	.284	$1\frac{19}{32}''$	1"	$\frac{25}{32}''$	$\frac{1}{16}''$	2	.4
40H16	H	$\frac{3}{8}$ - $1\frac{1}{2}$	2.80	2.563	16	3	.284	$1\frac{19}{32}''$	$1\frac{1}{4}''$	$1\frac{1}{8}''$	$\frac{5}{32}''$	$2\frac{1}{2}''$	.6
40H17	H	$\frac{3}{8}$ - $1\frac{1}{2}$	2.96	2.721	17	3	.284	$1\frac{1}{2}''$	$1\frac{1}{4}''$	$1\frac{1}{32}''$	$\frac{1}{16}''$	$2\frac{1}{2}''$	.7
40H18	H	$\frac{3}{8}$ - $1\frac{1}{2}$	3.14	2.879	18	3	.284	$1\frac{1}{2}''$	$1\frac{1}{4}''$	$1\frac{1}{32}''$	$\frac{1}{16}''$	$2\frac{1}{2}''$	.7
40P18	P1	$\frac{1}{2}$ - $1\frac{3}{4}$	3.30	3.038	18	4	.284	$2\frac{3}{16}''$	$1\frac{15}{16}''$	$1\frac{1}{32}''$	0	3	1.2
40H19	H	$\frac{3}{8}$ - $1\frac{1}{2}$	3.30	3.038	19	3	.284	$1\frac{1}{2}''$	$1\frac{1}{4}''$	$1\frac{1}{32}''$	$\frac{1}{16}''$	$2\frac{1}{2}''$	.8
40P19	P1	$\frac{1}{2}$ - $1\frac{3}{4}$	3.30	3.038	19	4	.284	$2\frac{3}{16}''$	$1\frac{15}{16}''$	$1\frac{21}{32}''$	0	3	1.3
40H20	H	$\frac{3}{8}$ - $1\frac{1}{2}$	3.45	3.196	20	3	.284	$1\frac{1}{2}''$	$1\frac{1}{4}''$	$1\frac{1}{32}''$	$\frac{1}{16}''$	$2\frac{1}{2}''$	.9
40P20	P1	$\frac{1}{2}$ - $1\frac{3}{4}$	3.45	3.196	20	4	.284	$2\frac{3}{16}''$	$1\frac{15}{16}''$	$1\frac{21}{32}''$	0	3	1.3
40H21	H	$\frac{3}{8}$ - $1\frac{1}{2}$	3.62	3.355	21	3	.284	$1\frac{1}{2}''$	$1\frac{1}{4}''$	$1\frac{1}{32}''$	$\frac{1}{16}''$	$2\frac{1}{2}''$	.9
40P21	P1	$\frac{1}{2}$ - $1\frac{3}{4}$	3.62	3.355	21	4	.284	$2\frac{3}{16}''$	$1\frac{15}{16}''$	$1\frac{21}{32}''$	0	3	1.5
40H22	H	$\frac{3}{8}$ - $1\frac{1}{2}$	3.75	3.513	22	3	.284	$1\frac{1}{2}''$	$1\frac{1}{4}''$	$1\frac{1}{32}''$	$\frac{1}{16}''$	$2\frac{1}{2}''$	.9
40P22	P1	$\frac{1}{2}$ - $1\frac{3}{4}$	3.75	3.513	22	4	.284	$2\frac{3}{16}''$	$1\frac{15}{16}''$	$1\frac{21}{32}''$	0	3	1.6
40H23	H	$\frac{3}{8}$ - $1\frac{1}{2}$	3.94	3.672	23	3	.284	$1\frac{1}{2}''$	$1\frac{1}{4}''$	$1\frac{1}{32}''$	$\frac{1}{16}''$	$2\frac{1}{2}''$	1.0
40P23	P1	$\frac{1}{2}$ - $1\frac{3}{4}$	3.94	3.672	23	4	.284	$2\frac{3}{16}''$	$1\frac{15}{16}''$	$1\frac{21}{32}''$	0	3	1.7
40H24	H	$\frac{3}{8}$ - $1\frac{1}{2}$	4.10	3.831	24	3	.284	$1\frac{1}{2}''$	$1\frac{1}{4}''$	$1\frac{1}{32}''$	$\frac{1}{16}''$	$2\frac{1}{2}''$	1.2
40P24	P1	$\frac{1}{2}$ - $1\frac{3}{4}$	4.10	3.831	24	4	.284	$2\frac{3}{16}''$	$1\frac{15}{16}''$	$1\frac{21}{32}''$	0	3	1.8
40H25	H	$\frac{3}{8}$ - $1\frac{1}{2}$	4.26	3.989	25	4	.284	$1\frac{1}{2}''$	$1\frac{1}{4}''$	$1\frac{1}{32}''$	$\frac{1}{16}''$	$2\frac{1}{2}''$	1.3
40P25	P1	$\frac{1}{2}$ - $1\frac{3}{4}$	4.26	3.989	25	4	.284	$2\frac{3}{16}''$	$1\frac{15}{16}''$	$1\frac{21}{32}''$	0	3	2.0
40H26	H	$\frac{3}{8}$ - $1\frac{1}{2}$	4.42	4.148	26	3	.284	$1\frac{1}{2}''$	$1\frac{1}{4}''$	$1\frac{1}{32}''$	$\frac{1}{16}''$	$2\frac{1}{2}''$	1.4
40P26	P1	$\frac{1}{2}$ - $1\frac{3}{4}$	4.42	4.148	26	4	.284	$2\frac{3}{16}''$	$1\frac{15}{16}''$	$1\frac{21}{32}''$	0	3	2.0
40H27	H	$\frac{3}{8}$ - $1\frac{1}{2}$	4.58	4.307	27	3	.284	$1\frac{1}{2}''$	$1\frac{1}{4}''$	$1\frac{1}{32}''$	$\frac{1}{16}''$	$2\frac{1}{2}''$	1.4
40P27	P1	$\frac{1}{2}$ - $1\frac{3}{4}$	4.58	4.307	27	4	.284	$2\frac{3}{16}''$	$1\frac{15}{16}''$	$1\frac{21}{32}''$	0	3	2.1
40H28	H	$\frac{3}{8}$ - $1\frac{1}{2}$	4.74	4.466	28	3	.284	$1\frac{1}{2}''$	$1\frac{1}{4}''$	$1\frac{1}{32}''$	$\frac{1}{16}''$	$2\frac{1}{2}''$	1.5
40P28	P1	$\frac{1}{2}$ - $1\frac{3}{4}$	4.74	4.466	28	4	.284	$2\frac{3}{16}''$	$1\frac{15}{16}''$	$1\frac{21}{32}''$	0	3	2.2
40P29	P1	$\frac{1}{2}$ - $1\frac{3}{4}$	4.90	4.625	29	4	.284	$2\frac{3}{16}''$	$1\frac{15}{16}''$	$1\frac{21}{32}''$	0	3	2.3
40H30	H	$\frac{3}{8}$ - $1\frac{1}{2}$	5.06	4.783	30	3	.284	$1\frac{1}{2}''$	$1\frac{1}{4}''$	$1\frac{1}{32}''$	$\frac{1}{16}''$	$2\frac{1}{2}''$	1.6
40P30	P1	$\frac{1}{2}$ - $1\frac{3}{4}$	5.06	4.783	30	4	.284	$2\frac{3}{16}''$	$1\frac{1$				

# No.40

# No.40-2 | Sprockets with Split Taper Bushings



- Pitch  $1\frac{1}{2}''$
- Roller  $\phi$  0.312''
- Tooth width B1 0.284''

## Single-Split Taper Bushed

Part No.	Bushing	Bore Range	De	Dp	No. Teeth	Type	B1	OL	L	P	C	H	Wt. Less Bushing
40P34	P1	1/2 - 3/4	5.70	5.419	34	4	.284	2 3/16	1 15/16	1 21/32	0	3 3/8	2.8
40P35	P1	1/2 - 3/4	5.86	5.578	35	4	.284	2 3/16	1 15/16	1 21/32	0	3 3/8	2.9
40P36	P1	1/2 - 3/4	6.02	5.737	36	4	.284	2 3/16	1 15/16	1 21/32	0	3 3/8	3.1
40P37	P1	1/2 - 3/4	6.18	5.896	37	4	.284	2 3/16	1 15/16	1 21/32	0	3 3/8	3.3
40P38	P1	1/2 - 3/4	6.33	6.055	38	4	.284	2 3/16	1 15/16	1 21/32	0	3 3/8	3.3
40P40	P1	1/2 - 3/4	6.65	6.373	40	4	.284	2 3/16	1 15/16	1 21/32	0	3 3/8	3.5
40P41	P1	1/2 - 3/4	6.81	6.532	41	4	.284	2 3/16	1 15/16	1 21/32	0	3 3/8	3.6
40P42	P1	1/2 - 3/4	6.97	6.691	42	4	.284	2 3/16	1 15/16	1 21/32	0	3 3/8	3.9
40P44	P1	1/2 - 3/4	7.29	7.009	44	4	.284	2 3/16	1 15/16	1 21/32	0	3 3/8	4.0
40P45	P1	1/2 - 3/4	7.45	7.168	45	4	.284	2 3/16	1 15/16	1 21/32	0	3 3/8	4.2
40P47	P1	1/2 - 3/4	7.77	7.486	47	4	.284	2 3/16	1 15/16	1 21/32	0	3 3/8	4.6
40P48	P1	1/2 - 3/4	7.93	7.645	48	4	.284	2 3/16	1 15/16	1 21/32	0	3 3/8	4.8
40P50	P1	1/2 - 3/4	8.25	7.963	50	4	.284	2 3/16	1 15/16	1 21/32	0	3 3/8	5.0
40P54	P1	1/2 - 3/4	8.89	8.599	54	4	.284	2 3/16	1 15/16	1 21/32	0	3 3/8	5.5
40P56	P1	1/2 - 3/4	9.20	8.917	56	4	.284	2 3/16	1 15/16	1 21/32	0	3 3/8	5.9
40P60	P1	1/2 - 3/4	9.84	9.554	60	4	.284	2 3/16	1 15/16	1 21/32	0	3 3/8	6.6
40Q60	Q1	3/4 - 2 1/16	9.84	9.554	60	4	.284	2 25/32	2 1/2	2 7/32	0	4 1/8	8.8
40P70	P1	1/2 - 3/4	11.43	11.145	70	4	.284	2 3/16	1 15/16	1 21/32	0	3 3/8	8.6
40Q70	Q1	3/4 - 2 1/16	11.43	11.145	70	4	.284	2 25/32	2 1/2	2 7/32	0	4 1/8	11.0
40P72	Q1	3/4 - 2 1/16	11.75	11.463	72	4	.284	2 25/32	2 1/2	2 7/32	0	4 1/8	11.2
40Q80	Q1	3/4 - 2 1/16	13.13	12.736	80	4	.284	2 25/32	2 1/2	2 7/32	0	4 1/8	13.1
40Q84	Q1	3/4 - 2 1/16	13.66	13.372	84	4	.284	2 25/32	2 1/2	2 7/32	0	4 1/8	14.1
40Q96	Q1	3/4 - 2 1/16	15.57	15.281	96	4	.284	2 25/32	2 1/2	2 7/32	0	4 1/8	17.3
40Q112	Q1	3/4 - 2 1/16	18.12	17.828	112	4	.284	2 25/32	2 1/2	2 7/32	0	4 1/8	12.8

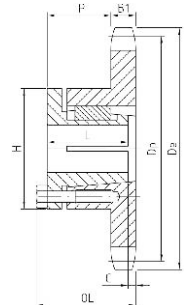

TYPE 4

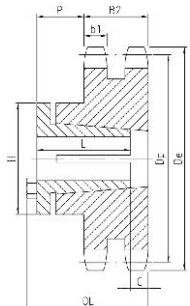

TYPE 11

- Pitch  $1\frac{1}{2}''$
- Roller  $\phi$  0.312''
- Tooth width b1 0.275''
- Tooth width B1 0.841''

## Double-Split Taper Bushed

Part Number	Bushing	Bore Range	De	Dp	No. Teeth	Type	b1	B2	OL	L	P	C	H	Wt. Less Bushing
D40H15	H	3/8 - 1 1/2	2.65	2.405	15	11	.275	.841	2 5/32	1 1/4	1 1/8	23/32	2 1/2	.9
D40H16	H	3/8 - 1 1/2	2.80	2.563	16	11	.275	.841	2 5/32	1 1/4	1 1/8	23/32	2 1/2	1.0
D40H17	H	3/8 - 1 1/2	2.96	2.721	17	11	.275	.841	2 5/32	1 1/4	1 1/8	23/32	2 1/2	1.1
D40P18	P1	3/8 - 1 3/4	3.14	2.879	18	16	.275	.841	3 3/16	1 15/16	1 3/8	1	3	1.8
D40P19	P1	1/2 - 3/4	3.30	3.038	19	12	.275	.841	2 15/32	1 15/16	1 3/8	9/32	3	1.4
D40P20	P1	1/2 - 1 3/8	3.45	3.196	20	12	.275	.841	2 15/32	1 15/16	1 3/8	7/32	3	1.6
D40P21	P1	1/2 - 1 3/8	3.62	3.355	21	12	.275	.841	2 15/32	1 15/16	1 3/8	7/32	3	1.8
D40P22	P1	1/2 - 1 3/8	3.75	3.513	22	12	.275	.841	2 15/32	1 15/16	1 3/8	7/32	3	2.0
D40P23	P1	1/2 - 1 3/8	3.94	3.672	23	12	.275	.841	2 3/16	1 15/16	1 3/32	0	3	2.0
D40Q24	P1	1/2 - 3/4	4.10	3.831	24	12	.275	.841	2 3/16	1 15/16	1 3/32	0	3	2.2
D40P25	P1	1/2 - 1 3/8	4.26	3.989	25	12	.275	.841	2 3/16	1 15/16	1 3/32	0	3	2.5
D40P26	P1	1/2 - 1 3/8	4.42	4.148	26	12	.275	.841	2 3/16	1 15/16	1 3/32	0	3	2.7
D40P28	P1	1/2 - 1 3/8	4.70	4.466	28	12	.275	.841	2 3/16	1 15/16	1 3/32	0	3	3.1
D40Q30	Q1	3/4 - 2 1/16	5.06	4.783	30	12	.275	.841	2 25/32	2 1/2	2 1/32	0	4 1/8	4.2
D40Q32	Q1	3/4 - 2 1/16	5.38	5.101	32	12	.275	.841	2 25/32	2 1/2	2 1/32	0	4 1/8	5.3
D40Q35	Q1	3/4 - 2 1/16	5.86	5.578	35	12	.275	.841	2 25/32	2 1/2	2 1/32	0	4 1/8	6.1
D40Q38	Q1	3/4 - 2 1/16	6.02	5.737	38	12	.275	.841	2 25/32	2 1/2	2 1/32	0	4 1/8	6.5
D40Q40	Q1	3/4 - 2 1/16	6.65	6.373	40	12	.275	.841	2 25/32	2 1/2	2 1/32	0	4 1/8	7.9
D40Q42	Q1	3/4 - 2 1/16	6.97	6.691	42	12	.275	.841	2 25/32	2 1/2	2 1/32	0	4 1/8	8.9
D40Q45	Q1	3/4 - 2 1/16	7.45	7.168	45	12	.275	.841	2 25/32	2 1/2	2 1/32	0	4 1/8	10.1
D40Q48	Q1	3/4 - 2 1/16	7.93	7.645	48	12	.275	.841	2 25/32	2 1/2	2 1/32	0	4 1/8	11.8
D40Q52	Q1	3/4 - 2 1/16	8.57	8.281	52	12	.275	.841	2 25/32	2 1/2	2 1/32	0	4 1/8	12.6
D40Q54	Q1	3/4 - 2 1/16	8.89	8.599	54	12	.275	.841	2 25/32	2 1/2	2 1/32	0	4 1/8	14.3
D40Q60	Q1	3/4 - 2 1/16	9.84	9.554	60	12	.275	.841	2 25/32	2 1/2	2 1/32	0	4 1/8	17.4
D40Q68	Q1	3/4 - 2 1/16	11.12	10.826	68	12	.275	.841	2 25/32	2 1/2	2 1/32	0	4 1/8	21.5
D40Q72	Q1	3/4 - 2 1/16	11.75	11.463	72	12	.275	.841	2 25/32	2 1/2	2 1/32	0	4 1/8	25.0
D40Q76	Q1	3/4 - 2 1/16	12.39	12.099	76	12	.275	.841	2 25/32	2 1/2	2 1/32	0	4 1/8	26.9
D40Q84	Q1	3/4 - 2 1/16	13.66	13.372	84	12	.275	.841	2 25/32	2 1/2	2 1/32	0	4 1/8	34.1
D40Q85	Q1	3/4 - 2 1/16	15.41	15.122	95	12	.275	.841	2 25/32	2 1/2	2 1/32	0	4 1/8	42.0
D40Q96	Q1	3/4 - 2 1/16	16.57	16.281	96	12	.275	.841	2 25/32	2 1/2	2 1/32	0	4 1/8	44.1
D40Q102	Q1	3/4 - 2 1/16	16.53	16.236	102	12	.275	.841	2 25/32	2 1/2	2 1/32	0	4 1/8	48.5
D40Q112	Q1	3/4 - 2 1/16	18.12	17.828	112	12	.275	.841	2 25/32	2 1/2	2 1/32	0	4 1/8	61.0

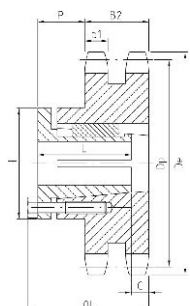

TYPE 12

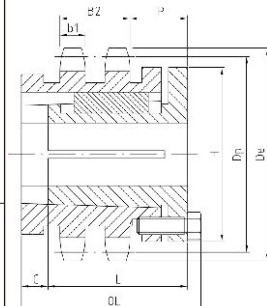

TYPE 16

Sprockets

# No.40-3 | Sprockets with Split Taper Bushings

- Pitch  $1\frac{1}{2}"$   Roller  $\phi$   $0.312"$
- Tooth width b1  $0.275"$   Tooth width B2  $0.841"$
- Tooth width B3  $1.407"$

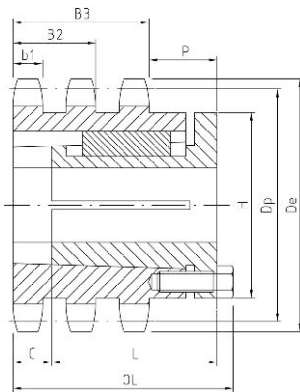

TYPE 22

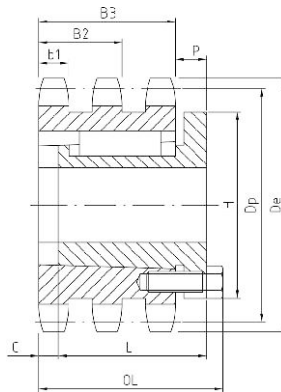

TYPE 23

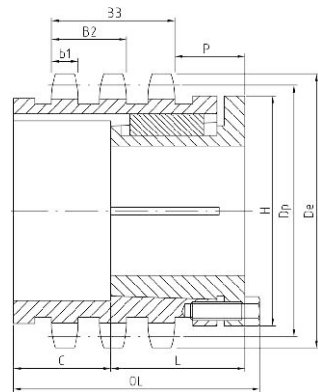

TYPE 27

## Triple-Split Taper Bushed

Part Number	Bushing	Bore Range	De	Dp	No. Teeth	Type	b1	B3	OL	L	P	C	H	Wt. Less Bushing
<b>HARDENED TEETH</b>	T40P18	P1	$\frac{1}{2} - 1\frac{3}{4}$	3.14"	2.879"	18	.275	1.407"	$3\frac{3}{4}$	$1\frac{9}{16}$	$\frac{1}{8}$	$1\frac{9}{16}$	3	1.9
	T40P19	P1	$\frac{1}{2} - 1\frac{3}{4}$	3.30	3.038	19	.275	1.407	$3\frac{1}{32}$	$1\frac{15}{16}$	$\frac{1}{8}$	$2\frac{7}{32}$	3	1.8
	T40P20	P1	$\frac{1}{2} - 1\frac{3}{4}$	3.46	3.196	20	.275	1.407	$2\frac{25}{32}$	$1\frac{15}{16}$	$\frac{1}{8}$	$2\frac{5}{32}$	3	2.0
	T40P23	P1	$\frac{1}{2} - 1\frac{3}{4}$	3.94	3.672	23	.275	1.407	$2\frac{9}{32}$	$1\frac{15}{16}$	$\frac{5}{8}$	$\frac{3}{32}$	3	2.3
	T40P24	P1	$\frac{1}{2} - 1\frac{3}{4}$	4.10	3.831	24	.275	1.407	$2\frac{9}{32}$	$1\frac{15}{16}$	$\frac{5}{8}$	$\frac{3}{32}$	3	2.6
	T40P25	P1	$\frac{1}{2} - 1\frac{3}{4}$	4.26	3.989	25	.275	1.407	$2\frac{9}{32}$	$1\frac{15}{16}$	$\frac{5}{8}$	$\frac{3}{32}$	3	3.0
	T40P27	P1	$\frac{1}{2} - 1\frac{3}{4}$	4.58	4.307	27	.275	1.407	$2\frac{9}{32}$	$1\frac{15}{16}$	$\frac{5}{8}$	$\frac{3}{32}$	3	3.3
	T40Q30	Q1	$\frac{3}{4} - 2\frac{11}{16}$	5.06	4.783	30	.275	1.407	$2\frac{25}{32}$	$2\frac{1}{2}$	$1\frac{3}{32}$	0	$4\frac{1}{8}$	4.5
	T40Q35	Q1	$\frac{3}{4} - 2\frac{11}{16}$	5.86	5.578	35	.275	1.407	$2\frac{25}{32}$	$2\frac{1}{2}$	$1\frac{3}{32}$	0	$4\frac{1}{8}$	6.9
	T40Q36	Q1	$\frac{3}{4} - 2\frac{11}{16}$	6.02	5.737	36	.275	1.407	$2\frac{25}{32}$	$2\frac{1}{2}$	$1\frac{3}{32}$	0	$4\frac{1}{8}$	7.6
	T40Q42	Q1	$\frac{3}{4} - 2\frac{11}{16}$	6.97	6.691	42	.275	1.407	$2\frac{25}{32}$	$2\frac{1}{2}$	$1\frac{3}{32}$	0	$4\frac{1}{8}$	11.1
	T40Q48	Q1	$\frac{3}{4} - 2\frac{11}{16}$	7.93	7.645	48	.275	1.407	$2\frac{25}{32}$	$2\frac{1}{2}$	$1\frac{3}{32}$	0	$4\frac{1}{8}$	15.2
T40Q52	Q1	$\frac{3}{4} - 2\frac{11}{16}$	8.57	8.281	52	.275	1.407	$2\frac{25}{32}$	$2\frac{1}{2}$	$1\frac{3}{32}$	0	$4\frac{1}{8}$	18.7	
T40Q54	Q1	$\frac{3}{4} - 2\frac{11}{16}$	8.89	8.599	54	.275	1.407	$2\frac{25}{32}$	$2\frac{1}{2}$	$1\frac{3}{32}$	0	$4\frac{1}{8}$	19.9	
T40Q60	Q1	$\frac{3}{4} - 2\frac{11}{16}$	9.84	9.554	60	.275	1.407	$2\frac{25}{32}$	$2\frac{1}{2}$	$1\frac{3}{32}$	0	$4\frac{1}{8}$	25.3	
T40Q68	Q1	$\frac{3}{4} - 2\frac{11}{16}$	11.12	10.826	68	.275	1.407	$2\frac{25}{32}$	$2\frac{1}{2}$	$1\frac{3}{32}$	0	$4\frac{1}{8}$	33.5	
T40Q72	Q1	$\frac{3}{4} - 2\frac{11}{16}$	11.75	11.463	72	.275	1.407	$2\frac{25}{32}$	$2\frac{1}{2}$	$1\frac{3}{32}$	0	$4\frac{1}{8}$	37.9	
T40Q76	Q1	$\frac{3}{4} - 2\frac{11}{16}$	12.39	12.099	76	.275	1.407	$2\frac{25}{32}$	$2\frac{1}{2}$	$1\frac{3}{32}$	0	$4\frac{1}{8}$	42.5	
T40Q84	Q1	$\frac{3}{4} - 2\frac{11}{16}$	13.66	13.372	84	.275	1.407	$2\frac{25}{32}$	$2\frac{1}{2}$	$1\frac{3}{32}$	0	$4\frac{1}{8}$	52.4	
T40Q95	Q1	$\frac{3}{4} - 2\frac{11}{16}$	15.41	15.122	95	.275	1.407	$2\frac{25}{32}$	$2\frac{1}{2}$	$1\frac{3}{32}$	0	$4\frac{1}{8}$	67.9	
T40Q102	Q1	$\frac{3}{4} - 2\frac{11}{16}$	16.53	16.236	102	.275	1.407	$2\frac{25}{32}$	$2\frac{1}{2}$	$1\frac{3}{32}$	0	$4\frac{1}{8}$	78.5	



**GOODWILL**

# No.50 | Sprockets with Split Taper Bushings

- Pitch **2"**
- Roller  $\phi$  **0.400"**
- Tooth width B1 **0.343"**



## Single-Split Taper Bushed

Part Number	Bushing	Bore Range	De	Dp	No. Teeth	Type	B1	OL	L	P	C	H	Wt. Less Bushing
H50G11	H	3/8 - 1"	2.50"	2.219"	11	3	.343"	1 <sup>19/32</sup>	1"	1 1/16"	13/32"	2"	.4
H50G12	H	3/8 - 1"	2.70	2.415	12	3	.343	1 <sup>19/32</sup>	1	1 1/16"	13/32	2	.5
H50G13	H	3/8 - 1"	2.91	2.612	13	3	.343	1 1/4	1	2 <sup>3/32</sup>	1/16	2	.6
H50H13	H	3/8 - 1 1/2	2.91	2.612	13	3	.343	1 <sup>21/32</sup>	1 1/4	1 1/8	7/32	2 1/2	.6
H50H14	H	3/8 - 1 1/2	3.11	2.809	14	3	.343	1 <sup>19/32</sup>	1 1/4	1 1/16	5/32	2 1/2	.6
H50H15	H	3/8 - 1 1/2	3.32	3.006	15	3	.343	1 1/2	1 1/4	1 1/16	0	2 1/2	.8
H50P15	H	1/2 - 1 3/4	3.32	3.006	15	4	.343	2 3/16	1 1/4	1 <sup>19/32</sup>	0	2 1/2	1.1
H50H16	H	3/8 - 1 1/2	3.52	3.204	16	4	.343	1 1/2	1 1/4	1 <sup>19/32</sup>	0	3	.9
H50P16	H	1/2 - 1 3/4	3.52	3.204	16	4	.343	2 3/16	1 1/4	1 <sup>19/32</sup>	0	3	1.4
H50H17	H	3/8 - 1 1/2	3.72	3.401	17	3	.343	1 1/2	1 1/4	1 3/16	1/16	2	1.0
H50P17	H	1/2 - 1 3/4	3.72	3.401	17	4	.343	2 3/16	1 1/4	1 <sup>19/32</sup>	0	3	1.4
H50H18	H	3/8 - 1 1/2	3.92	3.559	18	3	.343	1 1/2	1 1/4	1 <sup>19/32</sup>	1/16	2 1/2	1.1
H50P18	H	1/2 - 1 3/4	3.92	3.559	18	4	.343	2 3/16	1 1/4	1 <sup>19/32</sup>	0	3	1.8
H50H19	H	3/8 - 1 1/2	4.12	3.797	19	3	.343	1 1/2	1 1/4	1 <sup>19/32</sup>	1/16	2 1/2	1.3
H50P19	H	1/2 - 1 3/4	4.12	3.797	19	4	.343	2 3/16	1 1/4	1 <sup>19/32</sup>	0	3	1.8
H50H20	H	3/8 - 1 1/2	4.32	3.995	20	3	.343	1 1/2	1 1/4	1 <sup>19/32</sup>	1/16	2 1/2	1.5
H50P20	H	1/2 - 1 3/4	4.32	3.995	20	4	.343	2 3/16	1 1/4	1 <sup>19/32</sup>	0	3	2.0
H50H21	H	1/2 - 1 1/2	4.52	4.194	21	3	.343	1 1/2	1 1/4	1 <sup>19/32</sup>	1/16	2 1/2	1.4
H50P21	H	1/2 - 1 3/4	4.52	4.194	21	4	.343	2 3/16	1 1/4	1 <sup>19/32</sup>	0	3	2.1
H50H22	H	3/8 - 1 1/2	4.72	4.392	22	3	.343	1 1/2	1 1/4	1 <sup>19/32</sup>	1/16	2 1/2	1.5
H50P22	H	1/2 - 1 3/4	4.72	4.392	22	4	.343	2 3/16	1 1/4	1 <sup>19/32</sup>	0	3	2.2
H50H23	H	3/8 - 1 1/2	4.92	4.590	23	3	.343	1 1/2	1 1/4	1 <sup>19/32</sup>	1/16	2 1/2	1.7
H50P23	H	1/2 - 1 3/4	4.92	4.590	23	4	.343	2 3/16	1 1/4	1 <sup>19/32</sup>	0	3	2.4
H50Q23	H	1/2 - 1 1/2	4.92	4.590	23	4	.343	2 <sup>25/32</sup>	2 1/2	2 3/32	0	4 1/8	3.2
H50Q24	H	3/4 - 1 1/2	5.12	4.788	24	3	.343	1 1/2	1 1/4	1 <sup>19/32</sup>	1/16	2 1/2	1.8
H50P24	H	1/2 - 1 3/4	5.12	4.788	24	4	.343	2 3/16	1 1/4	1 <sup>19/32</sup>	0	3	2.6
H50Q24	H	3/4 - 2 <sup>11/16</sup>	5.12	4.788	24	4	.343	2 <sup>25/32</sup>	2 1/2	2 3/32	0	4 1/8	3.5
H50H25	H	3/8 - 1 1/2	5.32	4.987	25	3	.343	1 1/2	1 1/4	1 <sup>19/32</sup>	1/16	2 1/2	1.9
H50P25	H	1/2 - 1 3/4	5.32	4.987	25	4	.343	2 3/16	1 1/4	1 <sup>19/32</sup>	0	3	2.7
H50Q25	H	3/4 - 2 <sup>11/16</sup>	5.32	4.987	25	4	.343	2 <sup>25/32</sup>	2 1/2	2 5/32	0	4 1/8	3.6
H50H26	H	3/8 - 1 1/2	5.52	5.185	26	3	.343	1 1/2	1 1/4	1 <sup>19/32</sup>	1/16	2 1/2	2.0
H50P26	H	1/2 - 1 3/4	5.52	5.185	26	4	.343	2 3/16	1 1/4	1 <sup>19/32</sup>	0	3	2.8
H50Q26	H	3/4 - 2 <sup>11/16</sup>	5.52	5.185	26	4	.343	2 <sup>25/32</sup>	2 1/2	2 3/32	0	4 1/8	3.7
H50H27	H	3/8 - 1 1/2	5.72	5.384	27	3	.343	1 1/2	1 1/4	1 <sup>19/32</sup>	1/16	2 1/2	2.2
H50P27	H	1/2 - 1 3/4	5.72	5.384	27	4	.343	2 3/16	1 1/4	1 <sup>19/32</sup>	0	3	2.9
H50Q27	H	3/4 - 2 <sup>11/16</sup>	5.72	5.384	27	4	.343	2 <sup>25/32</sup>	2 1/2	2 5/32	0	4 1/8	3.8
H50H28	H	3/8 - 1 1/2	5.92	5.582	28	3	.343	1 1/2	1 1/4	2 3/32	1/16	2 1/2	2.5
H50P28	H	1/2 - 1 3/4	5.92	5.582	28	4	.343	2 3/16	1 1/4	1 <sup>19/32</sup>	0	3	3.0
H50Q28	H	3/4 - 2 <sup>11/16</sup>	5.92	5.582	28	4	.343	2 <sup>25/32</sup>	2 1/2	2 3/32	0	4 1/8	4.0
H50P29	H	1/2 - 1 3/4	6.12	5.781	29	4	.343	2 3/16	1 1/4	1 <sup>19/32</sup>	0	3	3.4
H50H30	H	3/8 - 1 1/2	6.32	5.979	30	3	.343	1 1/2	1 1/4	1 <sup>19/32</sup>	1/16	2 1/2	2.9
H50P30	H	1/2 - 1 3/4	6.32	5.979	30	4	.343	2 3/16	1 1/4	1 <sup>19/32</sup>	0	3	3.6
H50Q30	H	3/4 - 2 <sup>11/16</sup>	6.32	5.979	30	4	.343	2 <sup>25/32</sup>	2 1/2	2 3/32	0	4 1/8	5.6
H50H32	H	3/8 - 1 1/2	6.72	6.376	32	3	.343	1 1/2	1 1/4	1 <sup>19/32</sup>	1/16	2 1/2	3.2
H50H33	H	3/8 - 1 1/2	6.92	6.575	33	3	.343	1 1/2	1 1/4	1 <sup>19/32</sup>	1/16	2 1/2	3.4
H50H34	H	3/8 - 1 1/2	7.12	6.774	34	3	.343	1 1/2	1 1/4	1 <sup>19/32</sup>	1/16	2 1/2	3.7
H50H35	H	3/8 - 1 1/2	7.32	6.972	35	3	.343	1 1/2	1 1/4	1 <sup>19/32</sup>	1/16	2 1/2	3.8
H50H36	H	3/8 - 1 1/2	7.52	7.171	36	3	.343	1 1/2	1 1/4	1 <sup>19/32</sup>	1/16	2 1/2	4.0
H50H38	H	3/8 - 1 1/2	7.92	7.569	38	3	.343	1 1/2	1 1/4	1 <sup>19/32</sup>	1/16	2 1/2	4.4
H50H40	H	3/8 - 1 1/2	8.32	7.966	40	3	.343	1 1/2	1 1/4	1 <sup>19/32</sup>	1/16	2 1/2	4.8

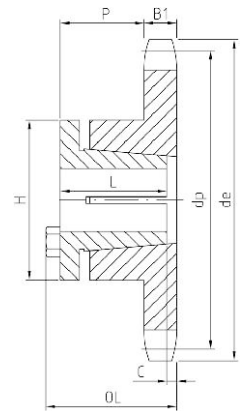

TYPE 3

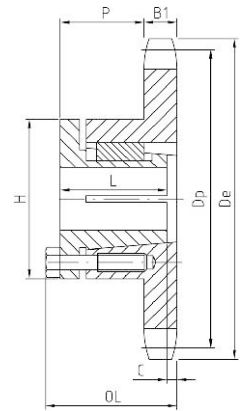

TYPE 4

Sprockets



**GOODWILL**

# No.50 | Sprockets with Split Taper Bushings

- Pitch **5/8"**     Roller  $\phi$  **0.400"**
- Tooth width B1 **0.343"**

## Single-Split Taper Bushed

Part Number	Bushing	Bore Range	De	Dp	No. Teeth	Type	B1	OL	L	P	C	H	Wt. Less Bushing
50G11	G	3/8 - 1"	2.50"	2.219"	11	3	.343"	1 19/32"	1"	1 1/16"	3/32"	2"	.5
50G12	G	3/8 - 1"	2.70	2.415	12	3	.343	1 19/32	1	1 1/16	3/32	2	.55
50H13	H	3/8 - 1 1/2	2.91	2.612	13	3	.343	1 21/32	1 1/4	1 1/8	7/32	2 1/2	.6
50H14	H	3/8 - 1 1/2	3.11	2.809	14	3	.343	1 19/32	1 1/4	1 1/8	5/32	2 1/2	.6
50H15	H	3/8 - 1 1/2	3.32	3.006	15	3	.343	1 1/2	1 1/4	1 1/8	5/32	2 1/2	.8
50P15	P1	1/2 - 1 3/4	3.32	3.006	15	4	.343	2 3/16	1 15/16	1 19/32	0	3	1.1
50H16	H	3/8 - 1 1/2	3.52	3.204	16	3	.343	1 1/2	1 1/4	1 1/8	5/32	2 1/2	.9
50P16	P1	1/2 - 1 1/2	3.52	3.204	16	4	.343	2 3/16	1 15/16	1 19/32	0	3	1.3
50H17	H	3/8 - 1 1/2	3.72	3.401	17	3	.343	1 1/2	1 1/4	1 1/8	5/32	2 1/2	1.0
50P17	P1	1/2 - 1 3/4	3.72	3.401	17	4	.343	2 3/16	1 15/16	1 19/32	0	3	1.4
50H18	H	3/8 - 1 1/2	3.92	3.599	18	3	.343	1 1/2	1 1/4	1 1/8	5/32	2 1/2	1.0
50P18	P1	1/2 - 1 3/4	3.92	3.599	18	4	.343	2 3/16	1 15/16	1 19/32	0	3	1.6
50H19	H	3/8 - 1 1/2	4.12	3.797	19	3	.343	1 1/2	1 1/4	1 1/8	5/32	2 1/2	1.1
50P19	P1	1/2 - 1 3/4	4.12	3.797	19	4	.343	2 3/16	1 15/16	1 19/32	0	3	1.8
50H20	H	3/8 - 1 1/2	4.32	3.995	20	3	.343	1 1/2	1 1/4	1 1/8	5/32	2 1/2	1.5
50P20	P1	1/2 - 1 3/4	4.32"	3.995"	20	4	.343	2 3/16"	1 15/16"	1 19/32"	0	3"	2.0
50P21	P1	1/2 - 1 3/4	4.52	4.194	21	4	.343	2 3/16	1 15/16	1 19/32	0	3	2.1
50P22	P1	1/2 - 1 3/4	4.70	4.392	22	4	.343	2 3/16	1 15/16	1 19/32	0	3	2.3
50P23	P1	1/2 - 1 3/4	4.92	3.599	23	4	.343	2 5/16	1 15/16	1 19/32	0	3	2.4
50Q23	Q1	3/4 - 2 11/16	4.92	3.599	23	4	.343	2 25/32	2 1/2	2 5/32	0	4 1/8	3.4
50P24	P1	1/2 - 1 3/4	5.12	4.788	24	4	.343	2 3/16	1 15/16	1 19/32	0	3	2.5
50Q24	Q1	3/4 - 2 11/16	5.12	4.788	24	4	.343	2 25/32	2 1/2	2 5/32	0	4 1/8	3.4
50P25	P1	1/2 - 1 3/4	5.32	4.987	25	4	.343	2 3/16	1 15/16	1 19/32	0	3	2.6
50Q25	Q1	3/4 - 2 11/16	5.32	4.987	25	4	.343	2 25/32	2 1/2	2 5/32	0	4 1/8	3.7
50P26	P1	1/2 - 1 3/4	5.52	5.185	26	4	.343	2 3/16	1 15/16	1 19/32	0	3	2.9
50Q26	Q1	3/4 - 2 11/16	5.52	5.185	26	4	.343	2 25/32	2 1/2	2 5/32	0	4 1/8	3.9
50P27	P1	1/2 - 1 3/4	5.72	5.384	27	4	.343	2 3/16	1 15/16	1 19/32	0	3	3.0
50Q27	Q1	3/4 - 2 11/16	5.72	5.384	27	4	.343	2 25/32	2 1/2	2 5/32	0	4 1/8	3.9
50P28	P1	1/2 - 1 3/4	5.92	5.582	28	4	.343	2 3/16	1 15/16	1 19/32	0	3	3.2
50Q28	Q1	3/4 - 2 11/16	5.92	5.582	28	4	.343	2 25/32	2 1/2	2 5/32	0	4 1/8	4.0
50P29	P1	1/2 - 1 3/4	6.12	5.781	29	4	.343	2 3/16	1 15/16	1 19/32	0	3	3.3
50P30	P1	1/2 - 1 3/4	6.32	5.979	30	4	.343	2 3/16	1 15/16	1 19/32	0	3	3.5
50Q30	Q1	3/4 - 2 11/16	6.32	5.979	30	4	.343	2 25/32	2 1/2	2 5/32	0	4 1/8	5.6
50P31	P1	1/2 - 1 3/4	6.52	6.178	31	4	.343	2 3/16	1 15/16	1 19/32	0	3	3.6
50P32	P1	1/2 - 1 3/4	6.72	6.376	32	4	.343	2 3/16	1 15/16	1 19/32	0	3	3.9
50Q32	Q1	3/4 - 2 11/16	6.72	6.376	32	4	.343	2 25/32	2 1/2	2 5/32	0	4 1/8	6.1
50P33	P1	1/2 - 1 3/4	6.92	6.575	33	4	.343	2 3/16	1 15/16	1 19/32	0	3	4.1
50Q33	Q1	3/4 - 2 11/16	6.92	6.575	33	4	.343	2 25/32	2 1/2	2 5/32	0	4 1/8	7.0
50P34	P1	1/2 - 1 3/4	7.12	6.774	34	4	.343	2 3/16	1 15/16	1 19/32	0	3	4.3
50P35	P1	1/2 - 1 3/4	7.32	6.972	35	4	.343	2 3/16	1 15/16	1 19/32	0	3	4.3
50Q35	Q1	3/4 - 2 11/16	7.32	6.972	35	4	.343	2 25/32	2 1/2	2 5/32	0	4 1/8	6.8
50P36	P1	1/2 - 1 3/4	7.52	7.171	36	4	.343	2 3/16	1 15/16	1 19/32	0	3	4.8
50Q36	Q1	3/4 - 2 11/16	7.52	7.171	36	4	.343	2 25/32	2 1/2	2 5/32	0	4 1/8	6.8
50Q37	Q1	3/4 - 2 11/16	7.72	7.370	37	4	.343	2 25/32	2 1/2	2 5/32	0	4 1/8	7.0
50Q38	Q1	3/4 - 2 11/16	7.92	7.569	38	4	.343	2 25/32	2 1/2	2 5/32	0	4 1/8	7.4
50Q39	Q1	3/4 - 2 11/16	8.12	7.767	39	4	.343	2 25/32	2 1/2	2 5/32	0	4 1/8	7.6
50Q40	Q1	3/4 - 2 11/16	8.32	7.966	40	4	.343	2 25/32	2 1/2	2 5/32	0	4 1/8	8.0
50Q41	Q1	3/4 - 2 11/16	8.52	8.165	41	4	.343	2 25/32	2 1/2	2 5/32	0	4 1/8	8.2
50Q42	Q1	3/4 - 2 11/16	8.72	8.363	42	4	.343	2 25/32	2 1/2	2 5/32	0	4 1/8	8.3
50Q44	Q1	3/4 - 2 11/16	9.11	8.761	44	4	.343	2 25/32	2 1/2	2 5/32	0	4 1/8	8.6
50Q45	Q1	3/4 - 2 11/16	9.31	8.960	45	4	.343	2 25/32	2 1/2	2 5/32	0	4 1/8	9.0
50Q47	Q1	3/4 - 2 11/16	9.71	9.357	47	4	.343	2 25/32	2 1/2	2 5/32	0	4 1/8	9.3
50Q48	Q1	3/4 - 2 11/16	9.91	9.556	48	4	.343	2 25/32	2 1/2	2 5/32	0	4 1/8	9.6
50Q50	Q1	3/4 - 2 11/16	10.31	9.954	50	4	.343	2 25/32	2 1/2	2 5/32	0	4 1/8	9.8
50Q54	Q1	3/4 - 2 11/16	11.11	10.749	54	4	.343	2 25/32	2 1/2	2 5/32	0	4 1/8	11.3
50Q56	Q1	3/4 - 2 11/16	11.50	11.147	56	4	.343	2 25/32	2 1/2	2 5/32	0	4 1/8	12.3
50Q60	Q1	3/4 - 2 11/16	12.30	11.942	60	4	.343	2 25/32	2 1/2	2 5/32	0	4 1/8	13.3
50Q70	Q1	3/4 - 2 11/16	14.29	13.931	70	4	.343	2 25/32	2 1/2	2 5/32	0	4 1/8	16.9
50Q72	Q1	3/4 - 2 11/16	14.69	14.329	72	4	.343	2 25/32	2 1/2	2 5/32	0	4 1/8	18.1
50Q80	Q1	3/4 - 2 11/16	16.28	15.920	80	4	.343	2 25/32	2 1/2	2 5/32	0	4 1/8	21.1
50Q84	Q1	3/4 - 2 11/16	17.08	16.715	84	4	.343	2 25/32	2 1/2	2 5/32	0	4 1/8	24.3
50Q96	Q1	3/4 - 2 11/16	19.47	19.102	96	4	.343	2 25/32	2 1/2	2 5/32	0	4 1/8	29.8
50Q112	Q1	3/4 - 2 11/16	22.65	22.285	112	4	.343	2 25/32	2 1/2	2 5/32	0	4 1/8	39.3

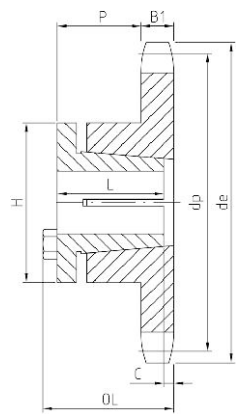

TYPE 3

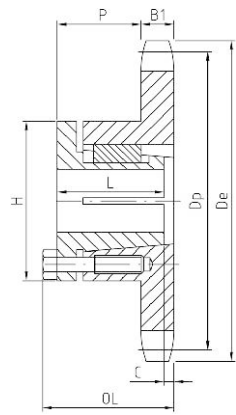

TYPE 4

Sprockets

# No.50-2

# No.50-3 | Sprockets with Split Taper Bushings



- Pitch  $5/8''$
- Roller  $\phi$  0.400''
- Tooth width b1 0.332''
- Tooth width B2 1.045''

## Double-Split Taper Bushed

Part Number	Bushing	Bore Range	De	Dp	No. Teeth	Type	B1	B2	OL	L	P	C	H	Wt. Less Bushing	
<b>HARDENED TEETH</b>	D50H14	H1	3/8 - 1 1/2"	3.11"	2.809"	14	11	.332"	1.045"	2 5/16"	1 1/4"	1 3/32"	7/8"	2 1/2"	1.2
	D50P15	P1	1/2 - 1 3/4"	3.32	3.006	15	16	.332	1.045	3 3/16"	1 15/16"	1 13/32"	1 1/4"	3	2.0
	D50P16	P1	1/2 - 1 3/4"	3.52	3.204	16	12	.332	1.045	2 11/16"	1 15/16"	1 13/32"	1/2"	3	1.6
	D50P17	P1	1/2 - 1 3/4"	3.72	3.401	17	12	.332	1.045	2 11/16"	1 15/16"	1 13/32"	1/2"	3	2.1
	D50P18	P1	1/2 - 1 3/4"	3.92	3.599	18	12	.332	1.045	2 11/16"	1 15/16"	1 13/32"	1/2"	3	2.5
	D50P19	P1	1/2 - 1 3/4"	4.12	3.797	19	12	.332	1.045	2 3/16"	1 15/16"	29/32"	0	3	2.0
	D50P20	P1	1/2 - 1 3/4"	4.32	3.995	20	12	.332	1.045	2 3/16"	1 15/16"	29/32"	0	3	2.5
	D50P21	P1	1/2 - 1 3/4"	4.52	4.194	21	12	.332	1.045	2 3/16"	1 15/16"	29/32"	0	3	2.8
	D50P22	P1	1/2 - 1 3/4"	4.70	4.392	22	12	.332	1.045	2 3/16"	1 15/16"	29/32"	0	3	3.2
	D50P23	P1	1/2 - 1 3/4"	4.92	4.590	23	12	.332	1.045	2 3/16"	1 15/16"	29/32"	0	3	3.6
	D50Q24	Q1	3/4 - 2 11/16"	5.12	4.788	24	12	.332	1.045	2 25/32"	2 1/2"	1 15/32"	0	4 1/8"	4.0
	D50Q25	Q1	3/4 - 2 11/16"	5.32	4.987	25	12	.332	1.045	2 25/32"	2 1/2"	1 15/32"	0	4 1/8"	4.5
D50Q26	Q1	3/4 - 2 11/16"	5.52	5.185	26	12	.332	1.045	2 25/32"	2 1/2"	1 15/32"	0	4 1/8"	5.3	
D50Q27	Q1	3/4 - 2 11/16"	5.72	5.384	27	12	.332	1.045	2 25/32"	2 1/2"	1 15/32"	0	4 1/8"	5.9	
D50Q28	Q1	3/4 - 2 11/16"	5.92	5.582	28	12	.332	1.045	2 25/32"	2 1/2"	1 15/32"	0	4 1/8"	6.3	
D50Q30	Q1	3/4 - 2 11/16"	6.32	5.979	30	12	.332	1.045	2 25/32"	2 1/2"	1 15/32"	0	4 1/8"	7.5	
D50Q32	Q1	3/4 - 2 11/16"	6.72	6.376	32	12	.332	1.045	2 25/32"	2 1/2"	1 15/32"	0	4 1/8"	8.5	
D50Q35	Q1	3/4 - 2 11/16"	7.32	6.972	35	12	.332	1.045	2 25/32"	2 1/2"	1 15/32"	0	4 1/8"	10.4	
D50Q36	Q1	3/4 - 2 11/16"	7.52	7.171	36	12	.332	1.045	2 25/32"	2 1/2"	1 15/32"	0	4 1/8"	11.0	
D50Q40	Q1	3/4 - 2 11/16"	8.32	7.966	40	12	.332	1.045	2 25/32"	2 1/2"	1 15/32"	0	4 1/8"	13.6	
D50Q42	Q1	3/4 - 2 11/16"	8.72	8.363	42	12	.332	1.045	2 25/32"	2 1/2"	1 15/32"	0	4 1/8"	15.0	
D50Q45	Q1	3/4 - 2 11/16"	9.31	8.960	45	12	.332	1.045	2 25/32"	2 1/2"	1 15/32"	0	4 1/8"	17.5	
D50Q48	Q1	3/4 - 2 11/16"	9.91	9.556	48	12	.332	1.045	2 25/32"	2 1/2"	1 15/32"	0	4 1/8"	20.4	
D50Q52	Q1	3/4 - 2 11/16"	10.71	10.351	52	12	.332	1.045	2 25/32"	2 1/2"	1 15/32"	0	4 1/8"	23.3	
D50Q54	Q1	3/4 - 2 11/16"	11.11	10.749	54	12	.332	1.045	2 25/32"	2 1/2"	1 15/32"	0	4 1/8"	23.3	
D50Q60	Q1	3/4 - 2 11/16"	12.30	11.942	60	12	.332	1.045	2 25/32"	2 1/2"	1 15/32"	0	4 1/8"	25.5	
D50Q72	Q1	3/4 - 2 11/16"	14.69	14.329	72	12	.332	1.045	2 25/32"	2 1/2"	1 15/32"	0	4 1/8"	43.1	
D50Q76	Q1	3/4 - 2 11/16"	15.49	15.124	76	12	.332	1.045	2 25/32"	2 1/2"	1 15/32"	0	4 1/8"	46.0	
D50Q84	Q1	3/4 - 2 11/16"	17.08	16.715	84	12	.332	1.045	2 25/32"	2 1/2"	1 15/32"	0	5 1/8"	56.7	
D50R95	R1	1 1/8 - 3 3/4"	19.27	18.903	95	12	.332	1.045	3 3/32"	2 7/8"	2 3/32"	0	5 1/8"	72.3	
D50R96	R1	1 1/8 - 3 3/4"	19.47	19.102	96	12	.332	1.045	3 3/32"	2 7/8"	2 3/32"	0	5 1/8"	80.7	
D50R102	R1	1 1/8 - 3 3/4"	20.66	20.295	102	12	.332	1.045	3 3/32"	2 7/8"	2 3/32"	0	5 1/8"	84.5	
D50R112	R1	1 1/8 - 3 3/4"	22.65	22.285	112	12	.332	1.045	3 3/32"	2 7/8"	2 3/32"	0	5 1/8"	93.2	

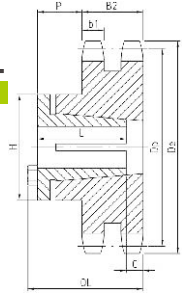

TYPE 11

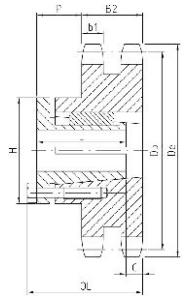

TYPE 12

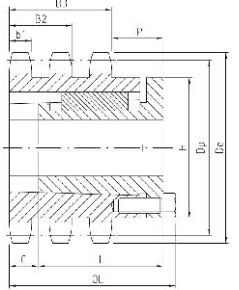

TYPE 22

- Pitch  $5/8''$
- Roller  $\phi$  0.400''
- Tooth width b1 0.332''
- Tooth width B2 1.045''
- Tooth width B3 1.758''

## Double-Split Taper Bushed

Part Number	Bushing	Bore Range	De	Dp	No. Teeth	Type	B1	B2	OL	L	P	C	H	Wt. Less Bushing	
<b>HARDENED TEETH</b>	T50P15	P2	3/4 - 1 3/4"	3.32"	3.006"	15	27	.332"	1.758"	4 1/8"	2 15/16"	1 3/8"	15/16"	3"	2.5
	T50P16	P2	3/4 - 1 3/4"	3.52	3.204	16	22	.332	1.758	3 3/8"	2 15/16"	1 3/8"	3/16"	3	2.4
	T50P17	P2	3/4 - 1 3/4"	3.72	3.401	17	22	.332	1.758	3 3/8"	2 15/16"	1 3/8"	3/16"	3	2.8
	T50P18	P2	3/4 - 1 3/4"	3.92	3.599	18	22	.332	1.758	3 3/8"	2 15/16"	1 3/8"	3/16"	3	3.4
	T50P19	P1	1/2 - 1 3/4"	4.12	3.797	19	24	.332	1.758	2 5/8"	1 15/16"	5/8"	7/16"	3	2.9
	T50P20	P1	1/2 - 1 3/4"	4.32	3.995	20	24	.332	1.758	2 5/8"	1 15/16"	5/8"	7/16"	3	3.1
	T50P21	P1	1/2 - 1 3/4"	4.52	4.194	21	24	.332	1.758	2 5/8"	1 15/16"	5/8"	7/16"	3	3.5
	T50P23	Q1	3/4 - 2 11/16"	4.92	4.590	23	24	.332	1.758	2 5/8"	1 15/16"	5/8"	7/16"	3	4.5
	T50Q24	Q1	3/4 - 2 11/16"	5.12	4.788	24	23	.332	1.758	2 25/32"	2 1/2"	3/4"	0	4 1/8"	4.7
	T50Q25	Q1	3/4 - 2 11/16"	5.32	4.987	25	23	.332	1.758	2 25/32"	2 1/2"	3/4"	0	4 1/8"	5.0
	T50Q26	Q1	3/4 - 2 11/16"	5.52	5.185	26	23	.332	1.758	2 25/32"	2 1/2"	3/4"	0	4 1/8"	5.9
	T50Q28	Q1	3/4 - 2 11/16"	5.92	5.582	28	23	.332	1.758	2 25/32"	2 1/2"	3/4"	0	4 1/8"	7.3
T50Q30	Q1	3/4 - 2 11/16"	6.32	5.979	30	23	.332	1.758	2 25/32"	2 1/2"	3/4"	0	4 1/8"	8.8	
T50Q32	Q1	3/4 - 2 11/16"	6.72	6.376	32	23	.332	1.758	2 25/32"	2 1/2"	3/4"	0	4 1/8"	10.9	
T50Q35	Q1	3/4 - 2 11/16"	7.32	6.972	35	23	.332	1.758	2 25/32"	2 1/2"	3/4"	0	4 1/8"	13.7	
T50Q36	Q1	3/4 - 2 11/16"	7.52	7.171	36	23	.332	1.758	2 25/32"	2 1/2"	3/4"	0	4 1/8"	14.6	
T50Q40	Q1	3/4 - 2 11/16"	8.32	7.966	40	23	.332	1.758	2 25/32"	2 1/2"	3/4"	0	4 1/8"	19.1	
T50Q42	Q1	3/4 - 2 11/16"	8.72	8.363	42	23	.332	1.758	2 25/32"	2 1/2"	3/4"	0	4 1/8"	21.5	
T50Q48	Q1	3/4 - 2 11/16"	9.91	9.556	48	23	.332	1.758	2 25/32"	2 1/2"	3/4"	0	4 1/8"	29.6	
T50Q52	Q1	3/4 - 2 11/16"	10.71	10.351	52	23	.332	1.758	2 25/32"	2 1/2"	3/4"	0	4 1/8"	36.4	
T50R60	R1	1 1/8 - 3 3/4"	12.30	11.942	60	22	.332	1.758	2 3/32"	2 7/8"	1 1/8"	0	5 3/8"	48.0	
T50R68	R1	1 1/8 - 3 3/4"	13.89	13.533	68	22	.332	1.758	2 3/32"	2 7/8"	1 1/8"	0	5 3/8"	63.5	
T50R72	R1	1 1/8 - 3 3/4"	14.69	14.329	72	22	.332	1.758	2 3/32"	2 7/8"	1 1/8"	0	5 3/8"	72.0	
T50R76	R1	1 1/8 - 3 3/4"	15.49	15.124	76	22	.332	1.758	2 3/32"	2 7/8"	1 1/8"	0	5 3/8"	81.0	
T50R84	R1	1 1/8 - 3 3/4"	17.08	16.715	84	22	.332	1.758	2 3/32"	2 7/8"	1 1/8"	0	5 3/8"	100.0	
T50R95	R1	1 1/8 - 3 3/4"	19.27	18.903	95	22	.332	1.758	2 3/32"	2 7/8"	1 1/8"	0	5 3/8"	130.0	
T50R102	R1	1 1/8 - 3 3/4"	20.66	20.295	102	22	.332	1.758	2 3/32"	2 7/8"	1 1/8"	0	5 3/8"	151.0	

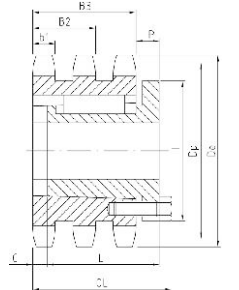

TYPE 23

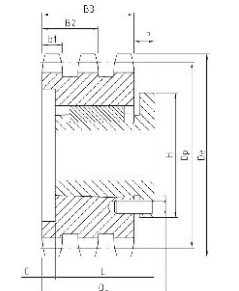

TYPE 24

# No.60 | Sprockets with Split Taper Bushings

- Pitch  $3/4''$
- Roller  $\phi$   $0.468''$
- Tooth width B1  $0.459''$

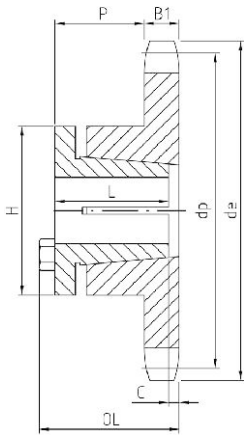

TYPE 3

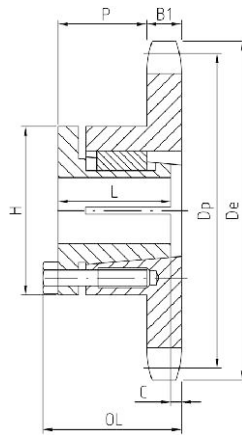

TYPE 4



## Single-Split Taper Bushed

Part Number	Bushing	Bore Range	De	Dp	No. Teeth	Type	B1	OL	L	P	C	H	Wt. Less Bushing
H60G10	G	3/8 - 1/2	2.76"	2.427"	10	3	.459"	1 3/4"	1"	1 3/32"	9/16"	2	.6
H60H11	H	3/8 - 1/2	2.96	2.662	11	3	.459	1 13/16	1 1/4"	1 5/32"	3/8	2 1/2	.7
H60H12	H	3/8 - 1/2	3.25	2.898	12	3	.459	1 3/4	1 1/4	1 3/32"	5/16	2 1/2	.8
H60H13	H	3/8 - 1/2	3.45	3.134	13	3	.459	1 1/2	1 1/4	1 27/32"	1/16	2 1/2	.8
H60P13	P1	1/2 - 3/4	3.45	3.134	13	4	.459	2 3/16	1 15/16	1 15/32"	0	3	1.2
H60H14	H	3/8 - 1/2	3.74	3.371	14	3	.459	1 1/2	1 1/4	1 27/32"	1/16	2 1/2	1.1
H60P14	P1	1/2 - 3/4	3.74	3.371	14	4	.459	2 3/16	1 15/16	1 15/32"	0	3	1.4
H60H15	H	3/8 - 1/2	3.98	3.607	15	3	.459	1 1/2	1 1/4	1 27/32"	1/16	2 1/2	1.4
H60P15	P1	1/2 - 3/4	3.98	3.607	15	4	.459	2 3/16	1 15/16	1 15/32"	0	3	1.7
H60H16	H	3/8 - 1/2	4.22	3.844	16	3	.459	1 1/2	1 1/4	1 27/32"	1/16	2 1/2	1.3
H60P16	P1	1/2 - 3/4	4.22	3.844	16	4	.459	2 3/16	1 15/16	1 15/32"	0	3	1.8
H60H17	H	3/8 - 1/2	4.46	4.082	17	3	.459	1 1/2	1 1/4	1 27/32"	1/16	2 1/2	1.5
H60P17	P1	1/2 - 3/4	4.46	4.082	17	4	.459	2 3/16	1 15/16	1 15/32"	0	3	2.1
H60H18	H	3/8 - 1/2	4.70	4.319	18	3	.459	1 1/2	1 1/4	1 27/32"	1/16	2 1/2	1.7
H60P18	P1	1/2 - 3/4	4.70	4.319	18	4	.459	2 3/16	1 15/16	1 15/32"	0	3	2.2
H60H19	H	3/8 - 1/2	4.95	4.557	19	3	.459	1 1/2	1 1/4	1 27/32"	1/16	2 1/2	1.9
H60P19	P1	1/2 - 3/4	4.95	4.557	19	4	.459	2 3/16	1 15/16	1 15/32"	0	3	2.5
H60H20	H	3/8 - 1/2	5.19	4.794	20	3	.459	1 1/2	1 1/4	1 27/32"	1/16	2 1/2	2.1
H60P20	P1	1/2 - 3/4	5.19	4.794	20	4	.459	2 3/16	1 15/16	1 15/32"	0	3	3.1
H60Q20	Q1	3/4 - 2 11/16	5.19	4.794	20	4	.459	2 25/32	2 1/2	2 1/32"	0	4 1/8	3.5
H60P21	P1	1/2 - 3/4	5.43	5.032	21	4	.459	2 3/16	1 15/16	1 15/32"	0	3	2.9
H60Q21	Q1	3/4 - 2 11/16	5.43	5.032	21	4	.459	2 25/32	2 1/2	2 1/32"	0	4 1/8	3.6
H60H22	H	3/8 - 1/2	5.67	5.270	22	3	.459	1 1/2	1 1/4	1 27/32"	1/16	2 1/2	2.6
H60P22	P1	1/2 - 3/4	5.67	5.270	22	4	.459	2 3/16	1 15/16	1 15/32"	0	3	3.2
H60Q22	Q1	3/4 - 2 11/16	5.67	5.270	22	4	.459	2 25/32	2 1/2	2 1/32"	0	4 1/8	4.0
H60P23	P1	1/2 - 3/4	5.91	5.508	23	4	.459	2 3/16	1 15/16	1 15/32"	0	3	3.5
H60Q23	Q1	3/4 - 2 11/16	5.91	5.508	23	4	.459	2 25/32	2 1/2	2 1/32"	0	4 1/8	4.1
H60H24	H	3/8 - 1/2	6.15	5.746	24	3	.459	1 1/2	1 1/4	1 27/32"	1/16	2 1/2	3.0
H60P24	P1	1/2 - 3/4	6.15	5.746	24	4	.459	2 3/16	1 15/16	1 15/32"	0	3	3.8
H60Q24	Q1	3/4 - 2 11/16	6.15	5.746	24	4	.459	2 25/32	2 1/2	2 1/32"	0	4 1/8	4.5
H60P25	P1	1/2 - 3/4	6.39	5.984	25	4	.459	2 3/16	1 15/16	1 15/32"	0	3	4.1
H60Q25	Q1	3/4 - 2 11/16	6.39	5.984	25	4	.459	2 25/32	2 1/2	2 1/32"	0	4 1/8	5.9
H60P26	P1	1/2 - 3/4	6.63	6.222	26	4	.459	2 3/16	1 15/16	1 15/32"	0	3	4.3
H60Q26	Q1	3/4 - 2 11/16	6.63	6.222	26	4	.459	2 25/32	2 1/2	2 1/32"	0	4 1/8	6.3
H60P27	P1	1/2 - 3/4	6.87	6.640	27	4	.459	2 3/16	1 15/16	1 15/32"	0	3	4.5
H60Q27	Q1	3/4 - 2 11/16	6.87	6.640	27	4	.459	2 25/32	2 1/2	2 1/32"	0	4 1/8	6.4
H60P28	P1	1/2 - 3/4	7.11	6.999	28	4	.459	2 3/16	1 15/16	1 15/32"	0	3	4.9
H60Q28	Q1	3/4 - 2 11/16	7.11	6.999	28	4	.459	2 25/32	2 1/2	2 1/32"	0	4 1/8	6.9
H60Q29	Q1	3/4 - 2 11/16	7.35	6.937	29	4	.459	2 25/32	2 1/2	2 1/32"	0	4 1/8	7.3
H60P30	P1	1/2 - 3/4	7.59	7.175	30	4	.459	2 3/16	1 15/16	1 15/32"	0	3	5.6
H60Q30	Q1	3/4 - 2 11/16	7.59	7.175	30	4	.459	2 25/32	2 1/2	2 1/32"	0	4 1/8	7.6

Sprockets



# No.60 | Sprockets with Split Taper Bushings

Pitch  $\frac{3}{4}$ "     Roller  $\phi$  0.468"  
 Tooth width B1 0.459"

## Single-Split Taper Bushed

Part Number	Bushing	Bore Range	De	Dp	No. Teeth	Type	B1	OL	L	P	C	H	Wt. Less Bushing
60G10	G	$\frac{3}{8}-1$	2.76"	2.427"	10	3	.459"	$1\frac{3}{4}$ "	1"	$1\frac{3}{32}$ "	$\frac{9}{16}$ "	2"	.6
60H11	H	$\frac{3}{8}-1\frac{1}{2}$	2.96	2.662	11	3	.459	$1\frac{13}{16}$ "	$1\frac{1}{4}$ "	$1\frac{5}{32}$ "	$\frac{3}{8}$ "	$2\frac{1}{2}$ "	.7
60H12	H	$\frac{3}{8}-1\frac{1}{2}$	3.25	2.898	12	3	.459	$1\frac{3}{4}$ "	$1\frac{1}{4}$ "	$1\frac{3}{32}$ "	$\frac{5}{16}$ "	$2\frac{1}{2}$ "	.8
60H13	H	$\frac{3}{8}-1\frac{1}{2}$	3.45	3.134	13	3	.459	$1\frac{1}{2}$ "	$1\frac{1}{4}$ "	$27/32$ "	$\frac{1}{16}$ "	$2\frac{1}{2}$ "	.8
60P15	P	$\frac{1}{2}-2\frac{3}{4}$	3.45	3.134	13	4	.459	$2\frac{3}{16}$ "	$1\frac{15}{16}$ "	$1\frac{15}{32}$ "	0	3	1.1
60P13	P	$\frac{1}{2}-2\frac{3}{4}$	3.45	3.134	13	4	.459	$2\frac{3}{16}$ "	$1\frac{15}{16}$ "	$1\frac{15}{32}$ "	0	3	1.1
60H14	H	$\frac{3}{8}-1\frac{1}{2}$	3.74	3.371	14	3	.459	$1\frac{1}{2}$ "	$1\frac{1}{4}$ "	$27/32$ "	$\frac{1}{16}$ "	$2\frac{1}{2}$ "	1.0
60P14	P	$\frac{3}{8}-1\frac{1}{2}$	3.74	3.371	14	4	.459	$2\frac{3}{16}$ "	$1\frac{15}{16}$ "	$1\frac{15}{32}$ "	0	3	1.2
60H15	H	$\frac{3}{8}-1\frac{1}{2}$	3.98	3.607	15	3	.459	$1\frac{1}{2}$ "	$1\frac{1}{4}$ "	$27/32$ "	$\frac{1}{16}$ "	$2\frac{1}{2}$ "	1.2
60P15	P	$\frac{1}{2}-1\frac{3}{4}$	3.98	3.607	15	4	.459	$2\frac{3}{16}$ "	$1\frac{15}{16}$ "	$1\frac{15}{32}$ "	1	3	1.6
60P16	P	$\frac{1}{2}-1\frac{3}{4}$	4.22	3.844	16	4	.459	$2\frac{3}{16}$ "	$1\frac{15}{16}$ "	$1\frac{15}{32}$ "	0	3	2.0
60P17	P	$\frac{1}{2}-1\frac{3}{4}$	4.46	4.082	17	4	.459	$2\frac{3}{16}$ "	$1\frac{15}{16}$ "	$1\frac{15}{32}$ "	0	3	2.2
60P18	P	$\frac{1}{2}-1\frac{3}{4}$	4.70	4.319	18	4	.459	$2\frac{3}{16}$ "	$1\frac{15}{16}$ "	$1\frac{15}{32}$ "	0	3	2.4
60P19	P	$\frac{1}{2}-1\frac{3}{4}$	4.95	4.557	19	4	.459	$2\frac{3}{16}$ "	$1\frac{15}{16}$ "	$1\frac{15}{32}$ "	0	3	3.0
60P20	P	$\frac{1}{2}-1\frac{3}{4}$	5.19	4.794	20	4	.459	$2\frac{3}{16}$ "	$1\frac{15}{16}$ "	$1\frac{15}{32}$ "	0	3	3.5
60Q20	Q	$\frac{3}{4}-2\frac{11}{16}$	5.19	4.794	20	4	.459	$2\frac{25}{32}$ "	$2\frac{1}{2}$ "	$2\frac{1}{32}$ "	0	$4\frac{1}{8}$ "	3.5
60P21	P	$\frac{1}{2}-1\frac{3}{4}$	5.43	5.032	21	4	.459	$2\frac{3}{16}$ "	$1\frac{15}{16}$ "	$1\frac{15}{32}$ "	0	3	3.0
60Q21	Q	$\frac{3}{4}-2\frac{11}{16}$	5.43	5.032	21	4	.459	$2\frac{25}{32}$ "	$2\frac{1}{2}$ "	$2\frac{1}{32}$ "	0	$4\frac{1}{8}$ "	3.8
60P22	P	$\frac{1}{2}-1\frac{3}{4}$	5.67	5.270	22	4	.459	$2\frac{3}{16}$ "	$1\frac{15}{16}$ "	$1\frac{15}{32}$ "	0	3	3.3
60Q22	Q	$\frac{3}{4}-2\frac{11}{16}$	5.67	5.270	22	4	.459	$2\frac{25}{32}$ "	$2\frac{1}{2}$ "	$2\frac{1}{32}$ "	0	$4\frac{1}{8}$ "	4.1
60P23	P	$\frac{1}{2}-1\frac{3}{4}$	5.91	5.508	23	4	.459	$2\frac{3}{16}$ "	$1\frac{15}{16}$ "	$1\frac{15}{32}$ "	0	3	3.5
60Q23	Q	$\frac{3}{4}-2\frac{11}{16}$	5.91	5.508	23	4	.459	$2\frac{25}{32}$ "	$2\frac{1}{2}$ "	$2\frac{1}{32}$ "	0	$4\frac{1}{8}$ "	4.3
60P24	P	$\frac{3}{4}-1\frac{3}{4}$	6.15	5.746	24	4	.459	$2\frac{3}{16}$ "	$1\frac{15}{16}$ "	$1\frac{15}{32}$ "	0	3	3.9
60Q24	Q	$\frac{3}{4}-1\frac{3}{4}$	6.15	5.746	24	4	.459	$2\frac{25}{32}$ "	$2\frac{1}{2}$ "	$2\frac{1}{32}$ "	0	$4\frac{1}{8}$ "	4.5
60P25	P	$\frac{1}{2}-1\frac{3}{4}$	6.39	5.984	25	4	.459	$2\frac{3}{16}$ "	$1\frac{15}{16}$ "	$1\frac{15}{32}$ "	0	3	4.3
60Q25	Q	$\frac{3}{4}-2\frac{11}{16}$	6.39	5.984	25	4	.459	$2\frac{25}{32}$ "	$2\frac{1}{2}$ "	$2\frac{1}{32}$ "	0	$4\frac{1}{8}$ "	6.0
60P26	P	$\frac{1}{2}-1\frac{3}{4}$	6.63	6.222	26	4	.459	$2\frac{3}{16}$ "	$1\frac{15}{16}$ "	$1\frac{15}{32}$ "	0	3	4.3
60Q26	Q	$\frac{3}{4}-2\frac{11}{16}$	6.63	6.222	26	4	.459	$2\frac{25}{32}$ "	$2\frac{1}{2}$ "	$2\frac{1}{32}$ "	0	$4\frac{1}{8}$ "	6.4
60P27	P	$\frac{3}{4}-1\frac{3}{4}$	6.87	6.460	27	4	.459	$2\frac{3}{16}$ "	$1\frac{15}{16}$ "	$1\frac{15}{32}$ "	0	3	4.6
60Q27	Q	$\frac{3}{4}-1\frac{3}{4}$	6.87	6.460	27	4	.459	$2\frac{25}{32}$ "	$2\frac{1}{2}$ "	$2\frac{1}{32}$ "	0	$4\frac{1}{8}$ "	6.6
60P28	P	$\frac{1}{2}-1\frac{3}{4}$	7.11	6.699	28	4	.459	$2\frac{3}{16}$ "	$1\frac{15}{16}$ "	$1\frac{15}{32}$ "	0	3	5.0
60Q28	Q	$\frac{3}{4}-2\frac{11}{16}$	7.11	6.699	28	4	.459	$2\frac{25}{32}$ "	$2\frac{1}{2}$ "	$2\frac{1}{32}$ "	0	$4\frac{1}{8}$ "	6.9
60Q29	Q	$\frac{3}{4}-2\frac{11}{16}$	7.35	6.937	29	4	.459	$2\frac{25}{32}$ "	$2\frac{1}{2}$ "	$2\frac{1}{32}$ "	0	$4\frac{1}{8}$ "	7.3
60P30	P	$\frac{1}{2}-1\frac{3}{4}$	7.59	7.175	30	4	.459	$2\frac{3}{16}$ "	$1\frac{15}{16}$ "	$1\frac{15}{32}$ "	0	3	5.6
60Q30	Q	$\frac{3}{4}-2\frac{11}{16}$	7.59	7.175	30	4	.459	$2\frac{25}{32}$ "	$2\frac{1}{2}$ "	$2\frac{1}{32}$ "	0	$4\frac{1}{8}$ "	7.7
60Q31	Q	$\frac{3}{4}-2\frac{11}{16}$	7.83	7.413	31	4	.459	$2\frac{25}{32}$ "	$2\frac{1}{2}$ "	$2\frac{1}{32}$ "	0	$4\frac{1}{8}$ "	7.8
60Q32	Q	$\frac{3}{4}-2\frac{11}{16}$	8.07	7.652	32	4	.459	$2\frac{25}{32}$ "	$2\frac{1}{2}$ "	$2\frac{1}{32}$ "	0	$4\frac{1}{8}$ "	8.3
60Q33	Q	$\frac{3}{4}-2\frac{11}{16}$	8.30	7.890	33	4	.459	$2\frac{25}{32}$ "	$2\frac{1}{2}$ "	$2\frac{1}{32}$ "	0	$4\frac{1}{8}$ "	8.7
60Q34	Q	$\frac{3}{4}-2\frac{11}{16}$	8.54	8.129	34	4	.459	$2\frac{25}{32}$ "	$2\frac{1}{2}$ "	$2\frac{1}{32}$ "	0	$4\frac{1}{8}$ "	9.1
60Q35	Q	$\frac{3}{4}-2\frac{11}{16}$	8.78	8.367	35	4	.459	$2\frac{25}{32}$ "	$2\frac{1}{2}$ "	$2\frac{1}{32}$ "	0	$4\frac{1}{8}$ "	9.3
60Q36	Q	$\frac{3}{4}-2\frac{11}{16}$	9.02	8.605	36	4	.459	$2\frac{25}{32}$ "	$2\frac{1}{2}$ "	$2\frac{1}{32}$ "	0	$4\frac{1}{8}$ "	9.9
60Q37	Q	$\frac{3}{4}-2\frac{11}{16}$	9.26	8.844	37	4	.459	$2\frac{25}{32}$ "	$2\frac{1}{2}$ "	$2\frac{1}{32}$ "	0	$4\frac{1}{8}$ "	10.3
60Q38	Q	$\frac{3}{4}-2\frac{11}{16}$	9.50	9.082	38	4	.459	$2\frac{25}{32}$ "	$2\frac{1}{2}$ "	$2\frac{1}{32}$ "	0	$4\frac{1}{8}$ "	10.6
60Q39	Q	$\frac{3}{4}-2\frac{11}{16}$	9.74	9.321	39	4	.459	$2\frac{25}{32}$ "	$2\frac{1}{2}$ "	$2\frac{1}{32}$ "	0	$4\frac{1}{8}$ "	11.1
60Q40	Q	$\frac{3}{4}-2\frac{11}{16}$	9.98	9.559	40	4	.459	$2\frac{25}{32}$ "	$2\frac{1}{2}$ "	$2\frac{1}{32}$ "	0	$4\frac{1}{8}$ "	11.6
60Q41	Q	$\frac{3}{4}-2\frac{11}{16}$	10.22	9.798	41	4	.459	$2\frac{25}{32}$ "	$2\frac{1}{2}$ "	$2\frac{1}{32}$ "	0	$4\frac{1}{8}$ "	11.9
60Q42	Q	$\frac{3}{4}-2\frac{11}{16}$	10.46	10.036	42	4	.459	$2\frac{25}{32}$ "	$2\frac{1}{2}$ "	$2\frac{1}{32}$ "	0	$4\frac{1}{8}$ "	12.6
60Q44	Q	$\frac{3}{4}-2\frac{11}{16}$	10.94	10.513	44	4	.459	$2\frac{25}{32}$ "	$2\frac{1}{2}$ "	$2\frac{1}{32}$ "	0	$4\frac{1}{8}$ "	13.4
60Q45	Q	$\frac{3}{4}-2\frac{11}{16}$	11.18	10.752	45	4	.459	$2\frac{25}{32}$ "	$2\frac{1}{2}$ "	$2\frac{1}{32}$ "	0	$4\frac{1}{8}$ "	13.9
60Q47	Q	$\frac{3}{4}-2\frac{11}{16}$	11.65	11.229	47	4	.459	$2\frac{25}{32}$ "	$2\frac{1}{2}$ "	$2\frac{1}{32}$ "	0	$4\frac{1}{8}$ "	16.3
60Q48	Q	$\frac{3}{4}-2\frac{11}{16}$	11.89	11.467	48	4	.459	$2\frac{25}{32}$ "	$2\frac{1}{2}$ "	$2\frac{1}{32}$ "	0	$4\frac{1}{8}$ "	16.4
60Q50	Q	$\frac{3}{4}-2\frac{11}{16}$	12.37	11.945	50	4	.459	$2\frac{25}{32}$ "	$2\frac{1}{2}$ "	$2\frac{1}{32}$ "	0	$4\frac{1}{8}$ "	16.9
60Q54	Q	$\frac{3}{4}-2\frac{11}{16}$	13.33	12.899	54	4	.459	$2\frac{25}{32}$ "	$2\frac{1}{2}$ "	$2\frac{1}{32}$ "	0	$4\frac{1}{8}$ "	19.6
60Q56	Q	$\frac{3}{4}-2\frac{11}{16}$	13.81	13.376	56	4	.459	$2\frac{25}{32}$ "	$2\frac{1}{2}$ "	$2\frac{1}{32}$ "	0	$4\frac{1}{8}$ "	20.3
60Q60	Q	$\frac{3}{4}-2\frac{11}{16}$	14.73	14.331	60	4	.459	$2\frac{25}{32}$ "	$2\frac{1}{2}$ "	$2\frac{1}{32}$ "	0	$4\frac{1}{8}$ "	22.9
60Q70	Q	$\frac{3}{4}-2\frac{11}{16}$	17.12	16.717	70	4	.459	$2\frac{25}{32}$ "	$2\frac{1}{2}$ "	$2\frac{1}{32}$ "	0	$4\frac{1}{8}$ "	30.9
60R70	R	$1\frac{1}{8}-3\frac{3}{4}$	17.12	16.717	70	4	.459	$3\frac{5}{32}$ "	$2\frac{7}{8}$ "	$2\frac{13}{32}$ "	0	$5\frac{3}{8}$ "	31.8
60Q72	Q	$\frac{3}{4}-2\frac{11}{16}$	17.63	17.194	72	4	.459	$2\frac{25}{32}$ "	$2\frac{1}{2}$ "	$2\frac{1}{32}$ "	0	$4\frac{1}{8}$ "	31.9
60R72	R	$1\frac{1}{8}-3\frac{3}{4}$	17.63	17.194	72	4	.459	$3\frac{5}{32}$ "	$2\frac{7}{8}$ "	$2\frac{13}{32}$ "	0	$5\frac{3}{8}$ "	34.1
60Q80	Q	$\frac{3}{4}-2\frac{11}{16}$	19.54	19.103	80	4	.459	$2\frac{25}{32}$ "	$2\frac{1}{2}$ "	$2\frac{1}{32}$ "	0	$4\frac{1}{8}$ "	39.1
60R80	R	$1\frac{1}{8}-3\frac{3}{4}$	19.54	19.103	80	4	.459	$3\frac{5}{32}$ "	$2\frac{7}{8}$ "	$2\frac{13}{32}$ "	0	$5\frac{3}{8}$ "	41.5
60Q84	Q	$\frac{3}{4}-2\frac{11}{16}$	20.49	20.058	84	4	.459	$2\frac{25}{32}$ "	$2\frac{1}{2}$ "	$2\frac{1}{32}$ "	0	$4\frac{1}{8}$ "	41.6
60R84	R	$1\frac{1}{8}-3\frac{3}{4}$	20.49	20.058	84	4	.459	$3\frac{5}{32}$ "	$2\frac{7}{8}$ "	$2\frac{13}{32}$ "	0	$5\frac{3}{8}$ "	44.8
60Q96	Q	$\frac{3}{4}-2\frac{11}{16}$	23.36	22.922	96	4	.459	$2\frac{25}{32}$ "	$2\frac{1}{2}$ "	$2\frac{1}{32}$ "	0	$4\frac{1}{8}$ "	54.0
60Q96	Q	$\frac{3}{4}-2\frac{11}{16}$	23.36	22.922	96	4	.459	$2\frac{25}{32}$ "	$2\frac{1}{2}$ "	$2\frac{1}{32}$ "	0	$4\frac{1}{8}$ "	56.0
60R96	R	$1\frac{1}{8}-3\frac{3}{4}$	23.36	22.922	96	4	.459	$3\frac{5}{32}$ "	$2\frac{7}{8}$ "	$2\frac{13}{32}$ "	0	$5\frac{3}{8}$ "	63.0
60Q112	Q	$\frac{3}{4}-2\frac{11}{16}$	27.18	26.742	112	4	.459	$2\frac{25}{32}$ "	$2\frac{1}{2}$ "	$2\frac{1}{32}$ "	0	$4\frac{1}{8}$ "	73.0
60R112	R	$1\frac{1}{8}-3\frac{3}{4}$	27.18	26.742	112	4	.459	$3\frac{5}{32}$ "	$2\frac{7}{8}$ "	$2\frac{13}{32}$ "	0	$5\frac{3}{8}$ "	74.5

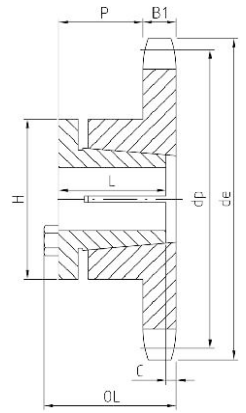

TYPE 3

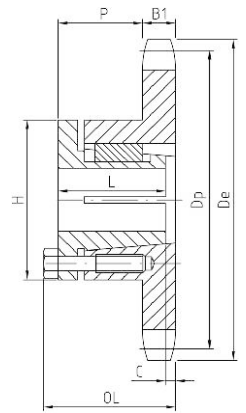

TYPE 4

Sprockets



**GOODWILL**

# No.60-2 | Sprockets with Split Taper Bushings

- Pitch  $3/4"$
- Roller  $\phi$   $0.468"$
- Tooth width  $b1$   $0.444"$
- Tooth width  $B2$   $1.341"$

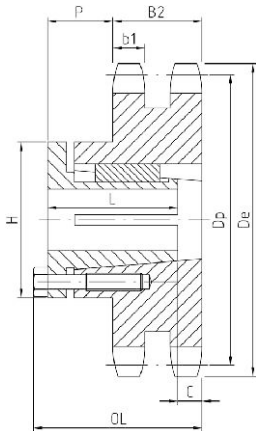

TYPE 12

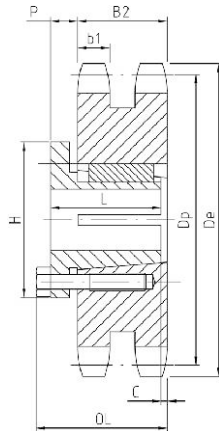

TYPE 13

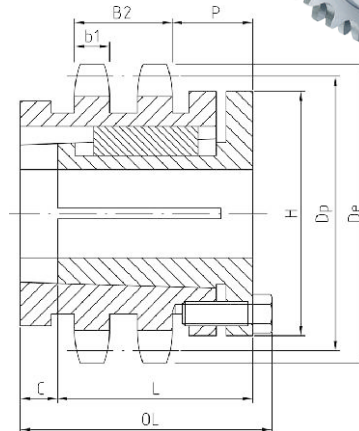

TYPE 16

## Double-Split Taper Bushed

Part Number	Bushing	Bore Range	De	Dp	No. Teeth	Type	B1	B2	OL	L	P	C	H	Wt. Less Bushing	
<b>HARDENED TEETH</b>	D60P13	P1	1/2 - 1 3/4	3.45	3.134	13	16	.444"	1.341"	3 13/16"	1 15/16"	1 13/32"	1 5/8"	3"	2.5
	D60P14	P1	1/2 - 1 3/4	3.74	3.371	14	12	.444	1.341	3	1 15/16"	1 13/32"	1 3/8"	3	2.3
	D60P15	P1	1/2 - 1 3/4	3.98	3.607	15	12	.444	1.341	3	1 15/16"	1 13/32"	1 3/8"	3	2.7
	D60P16	P1	1/2 - 1 3/4	4.22	3.844	16	13	.444	1.341	2 7/32"	1 15/16"	5/8"	1 1/32"	3	2.4
	D60P17	P1	1/2 - 1 3/4	4.46	4.082	17	13	.444	1.341	2 7/32"	1 15/16"	5/8"	1 1/32"	3	2.8
	D60P18	P1	1/2 - 1 3/4	4.70	4.319	18	13	.444	1.341	2 7/32"	1 15/16"	5/8"	1 1/32"	3	3.4
	D60P19	P1	1/2 - 1 3/4	4.95	4.557	19	13	.444	1.341	2 7/32"	1 15/16"	5/8"	1 1/32"	3	4.0
	D60P20	P1	1/2 - 1 3/4	5.19	4.794	20	13	.444	1.341	2 7/32"	1 15/16"	5/8"	1 1/32"	3	4.7
	D60Q21	Q1	3/4 - 2 11/16	5.43	5.032	21	12	.444	1.341	2 25/32"	2 1/2"	1 5/32"	0	4 1/8"	4.8
	D60Q22	Q1	3/4 - 2 11/16	5.67	5.270	22	12	.444	1.341	2 25/32"	2 1/2"	1 5/32"	0	4 1/8"	5.6
	D60Q23	Q1	3/4 - 2 11/16	5.91	5.508	23	12	.444	1.341	2 25/32"	2 1/2"	1 5/32"	0	4 1/8"	6.3
	D60Q24	Q1	3/4 - 2 11/16	6.15	5.746	24	12	.444	1.341	2 25/32"	2 1/2"	1 5/32"	0	4 1/8"	7.0
	D60Q25	Q1	3/4 - 2 11/16	6.39	5.984	25	12	.444	1.341	2 25/32"	2 1/2"	1 5/32"	0	4 1/8"	7.9
	D60Q26	Q1	3/4 - 2 11/16	6.63	6.222	26	12	.444	1.341	2 25/32"	2 1/2"	1 5/32"	0	4 1/8"	8.8
	D60Q27	Q1	3/4 - 2 11/16	6.87	6.460	27	12	.444	1.341	2 25/32"	2 1/2"	1 5/32"	0	4 1/8"	9.2
	D60Q28	Q1	3/4 - 2 11/16	7.11	6.699	28	12	.444	1.341	2 25/32"	2 1/2"	1 5/32"	0	4 1/8"	10.5
	D60Q30	Q1	3/4 - 2 11/16	7.59	7.175	30	12	.444	1.341	2 25/32"	2 1/2"	1 5/32"	0	4 1/8"	12.3
	D60Q32	Q1	3/4 - 2 11/16	8.07	7.652	32	12	.444	1.341	2 25/32"	2 1/2"	1 5/32"	0	4 1/8"	14.3
	D60Q35	Q1	3/4 - 2 11/16	8.78	8.367	35	12	.444	1.341	2 25/32"	2 1/2"	1 5/32"	0	4 1/8"	17.7
	D60Q36	Q1	3/4 - 2 11/16	9.02	8.605	36	12	.444	1.341	2 25/32"	2 1/2"	1 5/32"	0	4 1/8"	18.4
D60Q40	Q1	3/4 - 2 11/16	9.98	9.559	40	12	.444	1.341	2 25/32"	2 1/2"	1 5/32"	0	4 1/8"	23.9	
D60Q42	R1	3/4 - 2 11/16	10.46	10.036	42	12	.444	1.341	2 25/32"	2 1/2"	1 5/32"	0	4 1/8"	26.3	
D60R42	R1	1 1/8 - 3 3/4	10.46	10.036	42	12	.444	1.341	3 5/32"	2 7/8"	1 17/32"	0	5 3/8"	25.7	
D60R45	R1	1 1/8 - 3 3/4	11.18	10.752	45	12	.444	1.341	3 5/32"	2 7/8"	1 17/32"	0	5 3/8"	30.2	
D60R48	R1	1 1/8 - 3 3/4	11.89	11.467	48	12	.444	1.341	3 5/32"	2 7/8"	1 17/32"	0	5 3/8"	35.1	
D60R52	R1	1 1/8 - 3 3/4	12.85	12.422	52	12	.444	1.341	3 5/32"	2 7/8"	1 17/32"	0	5 3/8"	41.8	
D60R54	R1	1 1/8 - 3 3/4	13.33	12.899	54	12	.444	1.341	3 5/32"	2 7/8"	1 17/32"	0	5 3/8"	45.1	
D60R60	R1	1 1/8 - 3 3/4	14.76	14.331	60	12	.444	1.341	3 5/32"	2 7/8"	1 17/32"	0	5 3/8"	54.8	
D60R68	R1	1 1/8 - 3 3/4	16.67	16.240	68	12	.444	1.341	3 5/32"	2 7/8"	1 17/32"	0	5 3/8"	73.8	
D60R72	R1	1 1/8 - 3 3/4	17.63	17.194	72	12	.444	1.341	3 5/32"	2 7/8"	1 17/32"	0	5 3/8"	81.8	
D60R76	R1	1 1/8 - 3 3/4	18.58	18.149	76	12	.444	1.341	3 5/32"	2 7/8"	1 17/32"	0	5 3/8"	93.0	
D60R84	R1	1 1/8 - 3 3/4	20.49	20.058	84	12	.444	1.341	3 5/32"	2 7/8"	1 17/32"	0	5 3/8"	111.0	
D60R95	R1	1 1/8 - 3 3/4	23.12	22.683	95	12	.444	1.341	3 5/32"	2 7/8"	1 17/32"	0	5 3/8"	148.0	
D60R96	R1	1 1/8 - 3 3/4	23.36	22.922	96	12	.444	1.341	3 5/32"	2 7/8"	1 17/32"	0	5 3/8"	155.0	

Sprockets

# No.60-3

# No.80 | Sprockets with Split Taper Bushings



- Pitch  $3/4"$   Roller  $\phi$   $0.468"$
- Tooth width b1  $0.444"$   Tooth width B2  $1.341"$   Tooth width B3  $2.238"$

## Triple-Split Taper Bushed

Part Number	Bushing	Bore Range	De	Dp	No. Teeth	Type	B1	B2	OL	L	P	C	H	Wt. Less Bushing
<b>HARDENED TEETH</b>	T60P13	P2	3/4 - 1 3/4	3.49	3.134	13	.444"	2.238"	4 <sup>23/32</sup>	2 <sup>15/16</sup>	1 <sup>13/32</sup>	1 <sup>17/32</sup>	3"	3.3
	T60P14	P2	3/4 - 1 3/4	3.74	3.371	14	.444	2.238	3 <sup>29/32</sup>	2 <sup>15/16</sup>	1 <sup>13/32</sup>	1 <sup>23/32</sup>	3	3.3
	T60P15	P2	3/4 - 1 3/4	3.98	3.607	15	.444	2.238	3 <sup>29/32</sup>	2 <sup>15/16</sup>	1 <sup>13/32</sup>	1 <sup>23/32</sup>	3	4.0
	T60P16	P1	1/2 - 1 3/4	4.22	3.844	16	.444	2.238	3 1/8	1 <sup>15/16</sup>	5/8	1 <sup>15/16</sup>	3	3.4
	T60Q17	Q1	3/4 - 2 1/16	4.46	4.082	17	.444	2.238	5	3 1/2	1 <sup>21/32</sup>	1 <sup>13/32</sup>	4 1/8	4.6
	T60Q18	Q1	3/4 - 2 1/16	4.70	4.319	18	.444	2.238	4 3/16	3 1/2	1 <sup>21/32</sup>	1 <sup>13/32</sup>	4 1/8	5.0
	T60Q19	Q1	3/4 - 2 1/16	4.95	4.577	19	.444	2.238	4 3/16	3 1/2	1 <sup>21/32</sup>	1 <sup>13/32</sup>	4 1/8	5.9
	T60Q20	Q1	3/4 - 2 1/16	5.19	4.794	20	.444	2.238	4 3/16	3 1/2	1 <sup>21/32</sup>	1 <sup>13/32</sup>	4 1/8	7.0
	T60Q21	Q1	3/4 - 2 1/16	5.43	5.032	21	.444	2.238	3 1/4	2 1/2	3/4	1 <sup>15/32</sup>	4 1/8	5.7
	T60Q22	Q1	3/4 - 2 1/16	5.67	5.270	22	.444	2.238	3 1/4	2 1/2	3/4	1 <sup>15/32</sup>	4 1/8	6.6
	T60Q23	Q1	3/4 - 2 1/16	5.91	5.508	23	.444	2.238	2 <sup>25/32</sup>	2 1/2	1/4	0	4 1/8	7.7
	T60Q24	Q1	3/4 - 2 1/16	6.15	5.746	24	.444	2.238	2 <sup>25/32</sup>	2 1/2	1/4	0	4 1/8	8.8
T60Q25	Q1	3/4 - 2 1/16	6.39	5.984	25	.444	2.238	2 <sup>25/32</sup>	2 1/2	1/4	0	4 1/8	10.0	
T60Q26	Q1	3/4 - 2 1/16	6.63	6.222	26	.444	2.238	2 <sup>25/32</sup>	2 1/2	1/4	0	4 1/8	11.1	
T60Q27	Q1	3/4 - 2 1/16	6.87	6.460	27	.444	2.238	2 <sup>25/32</sup>	2 1/2	1/4	0	4 1/8	12.4	
T60Q28	Q1	3/4 - 2 1/16	7.11	6.699	28	.444	2.238	2 <sup>25/32</sup>	2 1/2	1/4	0	4 1/8	13.6	
T60R30	R1	1 1/8 - 3 3/4	7.59	7.175	30	.444	2.238	3 5/32	2 7/8	5/8	0	5 3/8	14.0	
T60R32	R1	1 1/8 - 3 3/4	8.07	7.652	32	.444	2.238	3 5/32	2 7/8	5/8	0	5 3/8	19.0	
T60R35	R1	1 1/8 - 3 3/4	8.78	8.367	35	.444	2.238	3 5/32	2 7/8	5/8	0	5 3/8	22.0	
T60R36	R1	1 1/8 - 3 3/4	9.02	8.605	36	.444	2.238	3 5/32	2 7/8	5/8	0	5 3/8	23.4	
T60R40	R1	1 1/8 - 3 3/4	9.98	9.559	40	.444	2.238	3 5/32	2 7/8	5/8	0	5 3/8	31.3	
T60R42	R1	1 1/8 - 3 3/4	10.46	10.036	42	.444	2.238	3 5/32	2 7/8	5/8	0	5 3/8	35.3	
T60R52	S1	1 1/8 - 3 3/4	12.85	12.422	52	.444	2.238	3 5/32	2 7/8	5/8	0	5 3/8	63.2	
T60S68	S1	1 1/16 - 4	16.67	16.240	68	.444	2.238	5 1/8	4 3/8	2 <sup>9/64</sup>	0	6 3/8	122.0	

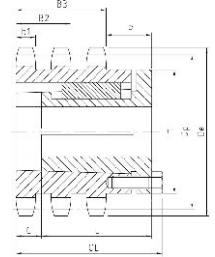

TYPE 22

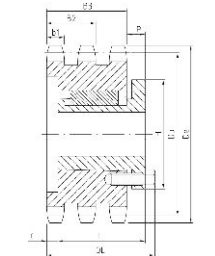

TYPE 24

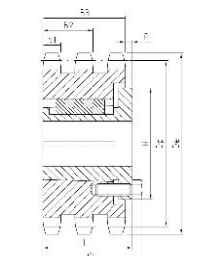

TYPE 25

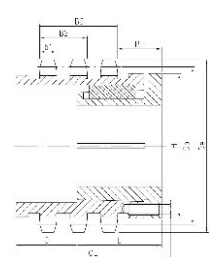

TYPE 27

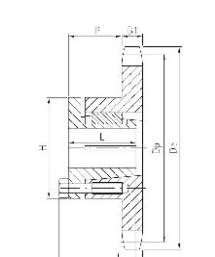

TYPE 4

- Pitch  $1"$   Roller  $\phi$   $0.625"$
- Tooth width B1  $0.575"$

## Single-Split Taper Bushed

Part Number	Bushing	Bore Range	De	Dp	No. Teeth	Type	B1	OL	L	P	C	H	Wt. Less Bushing
H80H11	H	3/8 - 1 1/2	3.98"	3.550"	11	3	.575"	1 1/2	1 1/4	1 3/4	1/16	2 1/2	1.3
H80P11	P1	1/2 - 1 3/4	3.98	3.550	11	4	.575	2 11/32	1 15/16	1 17/32	5/32	3	1.6
H80P12	P1	1/2 - 1 3/4	4.33	3.864	12	4	.575	2 11/32	1 15/16	1 3/8	0	3	2.0
H80P13	P1	1/2 - 1 3/4	4.66	4.179	13	4	.575	2 11/32	1 15/16	1 3/8	0	3	2.4
H80P14	P1	1/2 - 1 3/4	4.98	4.494	14	4	.575	2 11/32	1 15/16	1 3/8	0	3	2.6
H80Q14	Q1	3/4 - 2 1/16	4.98	4.494	14	4	.575	2 <sup>25/32</sup>	2 1/2	1 <sup>15/16</sup>	0	4 1/8	2.9
H80P15	P1	1/2 - 1 3/4	5.31	4.810	15	4	.575	2 3/16	1 <sup>15/16</sup>	1 3/8	0	3	3.0
H80Q15	Q1	3/4 - 2 1/16	5.31	4.810	15	4	.575	2 <sup>25/32</sup>	2 1/2	1 <sup>15/16</sup>	0	4 1/8	3.4
H80P16	P1	1/2 - 1 3/4	5.63	5.126	16	4	.575	2 3/16	1 <sup>15/16</sup>	1 3/8	0	3	3.5
H80Q16	Q1	3/4 - 2 1/16	5.63	5.126	16	4	.575	2 <sup>25/32</sup>	2 1/2	1 <sup>15/16</sup>	0	4 1/8	4.6
H80P17	P1	1/2 - 1 3/4	5.95	5.442	17	4	.575	2 3/16	1 <sup>15/16</sup>	1 3/8	0	3	3.8
H80Q17	Q1	3/4 - 2 1/16	5.95	5.442	17	4	.575	2 <sup>25/32</sup>	2 1/2	1 <sup>15/16</sup>	0	4 1/8	5.3
H80P18	P1	1/2 - 1 3/4	6.27	5.759	18	4	.575	2 3/16	1 <sup>15/16</sup>	1 3/8	0	3	4.4
H80Q18	Q1	3/4 - 2 1/16	6.27	5.759	18	4	.575	2 <sup>25/32</sup>	2 1/2	1 <sup>15/16</sup>	0	4 1/8	6.0
H80P19	P1	1/2 - 1 3/4	6.59	6.076	19	4	.575	2 3/16	1 <sup>15/16</sup>	1 3/8	0	3	4.9
H80Q19	Q1	3/4 - 2 1/16	6.59	6.076	19	4	.575	2 <sup>25/32</sup>	2 1/2	1 <sup>15/16</sup>	0	4 1/8	6.5
H80Q20	Q1	3/4 - 2 1/16	6.91	6.392	20	4	.575	2 <sup>25/32</sup>	2 1/2	1 <sup>15/16</sup>	0	4 1/8	7.0
H80Q21	Q1	3/4 - 2 1/16	7.24	6.710	21	4	.575	2 <sup>25/32</sup>	2 1/2	1 <sup>15/16</sup>	0	4 1/8	7.3
H80Q22	Q1	3/4 - 2 1/16	7.56	7.027	22	4	.575	2 <sup>25/32</sup>	2 1/2	1 <sup>15/16</sup>	0	4 1/8	8.2
H80Q23	Q1	3/4 - 2 1/16	7.88	7.344	23	4	.575	2 <sup>25/32</sup>	2 1/2	1 <sup>15/16</sup>	0	4 1/8	8.8
H80Q24	Q1	3/4 - 2 1/16	8.20	7.661	24	4	.575	2 <sup>25/32</sup>	2 1/2	1 <sup>15/16</sup>	0	4 1/8	9.1
H80Q25	Q1	3/4 - 2 1/16	8.52	7.979	25	4	.575	2 <sup>25/32</sup>	2 1/2	1 <sup>15/16</sup>	0	4 1/8	9.6
H80Q26	Q1	3/4 - 2 1/16	8.84	8.296	26	4	.575	2 <sup>25/32</sup>	2 1/2	1 <sup>15/16</sup>	0	4 1/8	10.6
H80Q27	Q1	3/4 - 2 1/16	9.16	8.614	27	4	.575	2 <sup>25/32</sup>	2 1/2	1 <sup>15/16</sup>	0	4 1/8	10.9
H80Q28	Q1	3/4 - 2 1/16	9.48	8.931	28	4	.575	2 <sup>25/32</sup>	2 1/2	1 <sup>15/16</sup>	0	4 1/8	12.4
H80Q29	Q1	3/4 - 2 1/16	9.80	9.249	29	4	.575	2 <sup>25/32</sup>	2 1/2	1 <sup>15/16</sup>	0	4 1/8	12.6
H80Q30	Q1	3/4 - 2 1/16	10.11	9.567	30	4	.575	2 <sup>25/32</sup>	2 1/2	1 <sup>15/16</sup>	0	4 1/8	13.4

Sprockets



**GOODWILL**

# No.80 | Sprockets with Split Taper Bushings

- Pitch 1"
- Roller  $\phi$  0.625"
- Tooth width B1 0.575"

## Single-Split Taper Bushed

Part Number	Bushing	Bore Range	De	Dp	No. Teeth	Type	B1	OL	L	P	C	H	Wt. Less Bushing
80H10	H	$\frac{3}{8}$ - $1\frac{1}{2}$ "	3.68"	3.236"	10	3	.575"	$2\frac{3}{32}$ "	$1\frac{1}{4}$ "	$1\frac{21}{64}$ "	$\frac{21}{32}$ "	$2\frac{1}{2}$ "	2.0
80H11	H	$\frac{3}{8}$ - $1\frac{1}{2}$ "	3.98	3.550	11	3	.575	$1\frac{1}{2}$ "	$1\frac{1}{4}$ "	$\frac{3}{4}$ "	$\frac{1}{16}$ "	$2\frac{1}{2}$ "	1.3
80P11	P1	$\frac{1}{2}$ - $1\frac{3}{4}$ "	3.98	3.550	11	4	.575	$2\frac{1}{32}$ "	$1\frac{15}{16}$ "	$1\frac{17}{32}$ "	$\frac{5}{32}$ "	$2\frac{1}{2}$ "	1.8
80P12	P1	$\frac{1}{2}$ - $1\frac{3}{4}$ "	4.33	3.864	12	4	.575	$2\frac{1}{16}$ "	$1\frac{15}{16}$ "	$1\frac{3}{8}$ "	0	3	2.0
80P13	P1	$\frac{1}{2}$ - $1\frac{3}{4}$ "	4.66	4.179	13	4	.575	$2\frac{1}{16}$ "	$1\frac{15}{16}$ "	$1\frac{3}{8}$ "	0	3	2.3
80P14	P1	$\frac{1}{2}$ - $1\frac{3}{4}$ "	4.98	4.494	14	4	.575	$2\frac{1}{16}$ "	$1\frac{15}{16}$ "	$1\frac{3}{8}$ "	0	3	2.7
80Q14	Q1	$\frac{3}{4}$ - $2\frac{11}{16}$ "	4.98	4.494	14	4	.575	$2\frac{25}{32}$ "	$2\frac{1}{2}$ "	$1\frac{15}{16}$ "	0	$4\frac{1}{8}$ "	3.0
80P15	P1	$\frac{1}{2}$ - $1\frac{3}{4}$ "	5.31	4.810	15	4	.575	$2\frac{1}{16}$ "	$1\frac{15}{16}$ "	$1\frac{3}{8}$ "	0	3	3.2
80Q15	Q1	$\frac{3}{4}$ - $2\frac{11}{16}$ "	5.31	4.810	15	4	.575	$2\frac{25}{32}$ "	$2\frac{1}{2}$ "	$1\frac{15}{16}$ "	0	$4\frac{1}{8}$ "	3.6
80P16	P1	$\frac{1}{2}$ - $1\frac{3}{4}$ "	5.63	5.126	16	4	.575	$2\frac{1}{16}$ "	$1\frac{15}{16}$ "	$1\frac{3}{8}$ "	0	3	3.6
80Q16	Q1	$\frac{3}{4}$ - $2\frac{11}{16}$ "	5.63	5.126	16	4	.575	$2\frac{25}{32}$ "	$2\frac{1}{2}$ "	$1\frac{15}{16}$ "	0	$4\frac{1}{8}$ "	4.6
80P17	P1	$\frac{1}{2}$ - $1\frac{3}{4}$ "	5.95	5.442	17	4	.575	$2\frac{1}{16}$ "	$1\frac{15}{16}$ "	$1\frac{3}{8}$ "	0	3	3.9
80Q17	Q1	$\frac{3}{4}$ - $2\frac{11}{16}$ "	5.95	5.442	17	4	.575	$2\frac{25}{32}$ "	$2\frac{1}{2}$ "	$1\frac{15}{16}$ "	0	$4\frac{1}{8}$ "	5.4
80P18	P1	$\frac{1}{2}$ - $1\frac{3}{4}$ "	6.27	5.759	18	4	.575	$2\frac{1}{16}$ "	$1\frac{15}{16}$ "	$1\frac{3}{8}$ "	0	3	4.5
80Q18	Q1	$\frac{3}{4}$ - $2\frac{11}{16}$ "	6.27	5.759	18	4	.575	$2\frac{25}{32}$ "	$2\frac{1}{2}$ "	$1\frac{15}{16}$ "	0	$4\frac{1}{8}$ "	6.0
80P19	P1	$\frac{1}{2}$ - $1\frac{3}{4}$ "	6.59	6.079	19	4	.575	$2\frac{1}{16}$ "	$1\frac{15}{16}$ "	$1\frac{3}{8}$ "	0	3	4.8
80Q19	Q1	$\frac{3}{4}$ - $2\frac{11}{16}$ "	6.59	6.079	19	4	.575	$2\frac{25}{32}$ "	$2\frac{1}{2}$ "	$1\frac{15}{16}$ "	0	$4\frac{1}{8}$ "	6.4
80Q20	Q1	$\frac{3}{4}$ - $2\frac{11}{16}$ "	6.91	6.392	20	4	.575	$2\frac{25}{32}$ "	$2\frac{1}{2}$ "	$1\frac{15}{16}$ "	0	$4\frac{1}{8}$ "	6.9
80Q21	Q1	$\frac{3}{4}$ - $2\frac{11}{16}$ "	7.24	6.710	21	4	.575	$2\frac{25}{32}$ "	$2\frac{1}{2}$ "	$1\frac{15}{16}$ "	0	$4\frac{1}{8}$ "	7.4
80Q22	Q1	$\frac{3}{4}$ - $2\frac{11}{16}$ "	7.56	7.027	22	4	.575	$2\frac{25}{32}$ "	$2\frac{1}{2}$ "	$1\frac{15}{16}$ "	0	$4\frac{1}{8}$ "	8.0
80Q23	Q1	$\frac{3}{4}$ - $2\frac{11}{16}$ "	7.88	7.344	23	4	.575	$2\frac{25}{32}$ "	$2\frac{1}{2}$ "	$1\frac{15}{16}$ "	0	$4\frac{1}{8}$ "	8.5
80Q24	Q1	$\frac{3}{4}$ - $2\frac{11}{16}$ "	8.20	7.661	24	4	.575	$2\frac{25}{32}$ "	$2\frac{1}{2}$ "	$1\frac{15}{16}$ "	0	$4\frac{1}{8}$ "	9.3
80Q25	Q1	$\frac{3}{4}$ - $2\frac{11}{16}$ "	8.52	7.979	25	4	.575	$2\frac{25}{32}$ "	$2\frac{1}{2}$ "	$1\frac{15}{16}$ "	0	$4\frac{1}{8}$ "	9.9
80Q26	Q1	$\frac{3}{4}$ - $2\frac{11}{16}$ "	8.84	8.296	26	4	.575	$2\frac{25}{32}$ "	$2\frac{1}{2}$ "	$1\frac{15}{16}$ "	0	$4\frac{1}{8}$ "	10.4
80Q27	Q1	$\frac{3}{4}$ - $2\frac{11}{16}$ "	9.16	8.614	27	4	.575	$2\frac{25}{32}$ "	$2\frac{1}{2}$ "	$1\frac{15}{16}$ "	0	$4\frac{1}{8}$ "	10.9
80Q28	Q1	$\frac{3}{4}$ - $2\frac{11}{16}$ "	9.48	8.931	28	4	.575	$2\frac{25}{32}$ "	$2\frac{1}{2}$ "	$1\frac{15}{16}$ "	0	$4\frac{1}{8}$ "	11.5
80Q29	Q1	$\frac{3}{4}$ - $2\frac{11}{16}$ "	9.80	9.567	29	4	.575	$2\frac{25}{32}$ "	$2\frac{1}{2}$ "	$1\frac{15}{16}$ "	0	$4\frac{1}{8}$ "	12.5
80Q30	Q1	$\frac{3}{4}$ - $2\frac{11}{16}$ "	10.11	9.567	30	4	.575	$2\frac{25}{32}$ "	$2\frac{1}{2}$ "	$1\frac{15}{16}$ "	0	$4\frac{1}{8}$ "	13.0
80Q31	Q1	$\frac{3}{4}$ - $2\frac{11}{16}$ "	10.43	9.885	31	4	.575	$2\frac{25}{32}$ "	$2\frac{1}{2}$ "	$1\frac{15}{16}$ "	0	$4\frac{1}{8}$ "	13.9
80Q32	Q1	$\frac{3}{4}$ - $2\frac{11}{16}$ "	10.75	10.202	32	4	.575	$2\frac{25}{32}$ "	$2\frac{1}{2}$ "	$1\frac{15}{16}$ "	0	$4\frac{1}{8}$ "	14.8
80Q33	Q1	$\frac{3}{4}$ - $2\frac{11}{16}$ "	11.07	10.520	33	4	.575	$2\frac{25}{32}$ "	$2\frac{1}{2}$ "	$1\frac{15}{16}$ "	0	$4\frac{1}{8}$ "	15.5
80Q34	Q1	$\frac{3}{4}$ - $2\frac{11}{16}$ "	11.39	10.838	34	4	.575	$2\frac{25}{32}$ "	$2\frac{1}{2}$ "	$1\frac{15}{16}$ "	0	$4\frac{1}{8}$ "	16.3
80Q35	Q1	$\frac{3}{4}$ - $2\frac{11}{16}$ "	11.71	11.156	35	4	.575	$2\frac{25}{32}$ "	$2\frac{1}{2}$ "	$1\frac{15}{16}$ "	0	$4\frac{1}{8}$ "	17.8
80Q36	Q1	$\frac{3}{4}$ - $2\frac{11}{16}$ "	11.98	11.474	36	4	.575	$2\frac{25}{32}$ "	$2\frac{1}{2}$ "	$1\frac{15}{16}$ "	0	$4\frac{1}{8}$ "	18.1
80R36	R1	$1\frac{1}{8}$ - $3\frac{3}{4}$ "	11.98	11.474	36	4	.575	$3\frac{5}{32}$ "	$2\frac{7}{8}$ "	$2\frac{5}{16}$ "	0	$5\frac{3}{8}$ "	19.5
80Q37	Q1	$\frac{3}{4}$ - $2\frac{11}{16}$ "	12.35	11.792	37	4	.575	$2\frac{25}{32}$ "	$2\frac{1}{2}$ "	$1\frac{15}{16}$ "	0	$4\frac{1}{8}$ "	18.5
80Q38	Q1	$\frac{3}{4}$ - $2\frac{11}{16}$ "	12.67	12.110	38	4	.575	$2\frac{25}{32}$ "	$2\frac{1}{2}$ "	$1\frac{15}{16}$ "	0	$4\frac{1}{8}$ "	20.0
80R39	R1	$1\frac{1}{8}$ - $3\frac{3}{4}$ "	12.99	12.428	39	4	.575	$3\frac{5}{32}$ "	$2\frac{7}{8}$ "	$2\frac{5}{16}$ "	0	$5\frac{3}{8}$ "	22.8
80Q40	Q1	$\frac{3}{4}$ - $2\frac{11}{16}$ "	13.31	12.746	40	4	.575	$2\frac{25}{32}$ "	$2\frac{1}{2}$ "	$1\frac{15}{16}$ "	0	$4\frac{1}{8}$ "	23.9
80R40	R1	$1\frac{1}{8}$ - $3\frac{3}{4}$ "	13.31	12.746	40	4	.575	$3\frac{5}{32}$ "	$2\frac{7}{8}$ "	$2\frac{5}{16}$ "	0	$5\frac{3}{8}$ "	23.4
80R41	R1	$1\frac{1}{8}$ - $3\frac{3}{4}$ "	13.63	13.064	41	4	.575	$3\frac{5}{32}$ "	$2\frac{7}{8}$ "	$2\frac{5}{16}$ "	0	$5\frac{3}{8}$ "	23.9
80Q42	Q1	$\frac{3}{4}$ - $2\frac{11}{16}$ "	13.94	13.382	42	4	.575	$2\frac{25}{32}$ "	$2\frac{1}{2}$ "	$1\frac{15}{16}$ "	0	$4\frac{1}{8}$ "	23.8
80R42	R1	$1\frac{1}{8}$ - $3\frac{3}{4}$ "	13.94	13.382	42	4	.575	$3\frac{5}{32}$ "	$2\frac{7}{8}$ "	$2\frac{5}{16}$ "	0	$5\frac{3}{8}$ "	25.4
80R44	R1	$1\frac{1}{8}$ - $3\frac{3}{4}$ "	14.58	14.018	44	4	.575	$3\frac{5}{32}$ "	$2\frac{7}{8}$ "	$2\frac{5}{16}$ "	0	$5\frac{3}{8}$ "	27.2
80Q45	Q1	$\frac{3}{4}$ - $2\frac{11}{16}$ "	14.90	14.336	45	4	.575	$2\frac{25}{32}$ "	$2\frac{1}{2}$ "	$1\frac{15}{16}$ "	0	$4\frac{1}{8}$ "	27.8
80R45	R1	$1\frac{1}{8}$ - $3\frac{3}{4}$ "	14.90	14.336	45	4	.575	$3\frac{5}{32}$ "	$2\frac{7}{8}$ "	$2\frac{5}{16}$ "	0	$5\frac{3}{8}$ "	28.5
80R47	R1	$1\frac{1}{8}$ - $3\frac{3}{4}$ "	15.54	14.972	47	4	.575	$3\frac{5}{32}$ "	$2\frac{7}{8}$ "	$2\frac{5}{16}$ "	0	$5\frac{3}{8}$ "	31.0
80Q48	Q1	$\frac{3}{4}$ - $2\frac{11}{16}$ "	15.86	15.290	48	4	.575	$2\frac{25}{32}$ "	$2\frac{1}{2}$ "	$1\frac{15}{16}$ "	0	$4\frac{1}{8}$ "	30.8
80R48	R1	$1\frac{1}{8}$ - $3\frac{3}{4}$ "	15.86	15.290	48	4	.575	$3\frac{5}{32}$ "	$2\frac{7}{8}$ "	$2\frac{5}{16}$ "	0	$5\frac{3}{8}$ "	32.3
80R50	R1	$1\frac{1}{8}$ - $3\frac{3}{4}$ "	16.50	15.926	50	4	.575	$3\frac{5}{32}$ "	$2\frac{7}{8}$ "	$2\frac{5}{16}$ "	0	$5\frac{3}{8}$ "	35.1
80Q54	Q1	$\frac{3}{4}$ - $2\frac{11}{16}$ "	17.77	17.198	54	4	.575	$2\frac{25}{32}$ "	$2\frac{1}{2}$ "	$1\frac{15}{16}$ "	0	$4\frac{1}{8}$ "	38.5
80R54	R1	$1\frac{1}{8}$ - $3\frac{3}{4}$ "	17.77	17.198	54	4	.575	$3\frac{5}{32}$ "	$2\frac{7}{8}$ "	$2\frac{5}{16}$ "	0	$5\frac{3}{8}$ "	40.8
80R56	R1	$1\frac{1}{8}$ - $3\frac{3}{4}$ "	18.41	17.835	56	4	.575	$3\frac{5}{32}$ "	$2\frac{7}{8}$ "	$2\frac{5}{16}$ "	0	$5\frac{3}{8}$ "	44.0
80Q60	Q1	$\frac{3}{4}$ - $2\frac{11}{16}$ "	19.68	19.107	60	4	.575	$2\frac{25}{32}$ "	$2\frac{1}{2}$ "	$1\frac{15}{16}$ "	0	$4\frac{1}{8}$ "	46.8
80R60	R1	$1\frac{1}{8}$ - $3\frac{3}{4}$ "	19.68	19.107	60	4	.575	$3\frac{5}{32}$ "	$2\frac{7}{8}$ "	$2\frac{5}{16}$ "	0	$5\frac{3}{8}$ "	47.3
80Q70	Q1	$\frac{3}{4}$ - $2\frac{11}{16}$ "	22.83	22.289	70	4	.575	$2\frac{25}{32}$ "	$2\frac{1}{2}$ "	$1\frac{15}{16}$ "	0	$4\frac{1}{8}$ "	60.0
80R70	R1	$1\frac{1}{8}$ - $3\frac{3}{4}$ "	22.83	22.289	70	4	.575	$3\frac{5}{32}$ "	$2\frac{7}{8}$ "	$2\frac{5}{16}$ "	0	$5\frac{3}{8}$ "	63.5
80Q72	Q1	$\frac{3}{4}$ - $2\frac{11}{16}$ "	23.46	22.926	72	4	.575	$2\frac{25}{32}$ "	$2\frac{1}{2}$ "	$1\frac{15}{16}$ "	0	$4\frac{1}{8}$ "	67.5
80R72	R1	$1\frac{1}{8}$ - $3\frac{3}{4}$ "	23.46	22.926	72	5	.575	$3\frac{5}{32}$ "	$2\frac{7}{8}$ "	$\frac{7}{8}$ "	$1\frac{1}{16}$ "	$5\frac{3}{8}$ "	69.4
80R80	R1	$1\frac{1}{8}$ - $3\frac{3}{4}$ "	26.01	25.471	80	5	.575	$3\frac{5}{32}$ "	$2\frac{7}{8}$ "	$\frac{7}{8}$ "	$1\frac{1}{16}$ "	$5\frac{3}{8}$ "	85.0
80R84	R1	$1\frac{1}{8}$ - $3\frac{3}{4}$ "	27.33	26.744	84	5	.575	$3\frac{5}{32}$ "	$2\frac{7}{8}$ "	$\frac{7}{8}$ "	$1\frac{1}{16}$ "	$5\frac{3}{8}$ "	90.0
80R96	R1	$1\frac{1}{8}$ - $3\frac{3}{4}$ "	31.15	30.563	96	5	.575	$3\frac{5}{32}$ "	$2\frac{7}{8}$ "	$\frac{7}{8}$ "	$1\frac{1}{16}$ "	$5\frac{3}{8}$ "	110.0
80S112	S1	$1\frac{11}{16}$ - $4\frac{1}{4}$ "	36.24	35.655	112	5	.575	$4\frac{3}{4}$ "	$4\frac{3}{8}$ "	$1\frac{1}{8}$ "	$2\frac{3}{4}$ "	$6\frac{3}{8}$ "	165.0

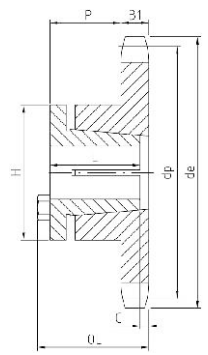

TYPE 3

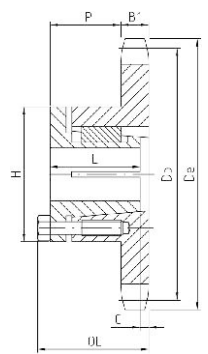

TYPE 4

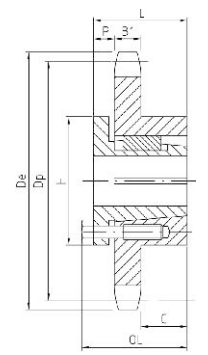

TYPE 5

Sprockets

# No.80-2

# No.80-3 | Sprockets with Split Taper Bushings



- Pitch **1"**  Roller  $\phi$  **0.625"**
- Tooth width b1 **0.557"**  Tooth width B2 **1.710"**

## Double-Split Taper Bushed

Part Number	Bushing	Bore Range	De	Dp	No. Teeth	Type	b1	B2	OL	L	P	C	H	Wt. Less Bushing	
<b>HARDEN TEETH</b>	D80P13	P1	1/2 - 1 3/4"	4.66"	4.179"	13	13	.557"	1.710"	2 19/32"	1 15/16"	1 5/8"	13/32"	3"	3.6
	D80Q14	Q2	1 - 2 5/8"	4.98	4.494	14	16	.557	1.710	4 5/8"	3 1/2"	1 3/4"	27/32"	4 1/8"	5.4
	D80Q15	Q2	1 - 2 5/8"	5.31	4.810	15	12	.557	1.710	3 25/32"	3 1/2"	1 3/4"	-	4 1/8"	5.4
	D80Q16	Q2	3/4 - 2 11/16"	5.63	5.126	16	13	.557	1.710	2 29/32"	2 1/2"	3/4"	-	4 1/8"	4.8
	D80Q17	Q1	3/4 - 2 11/16"	5.95	5.442	17	13	.557	1.710	2 29/32"	2 1/2"	3/4"	-	4 1/8"	6.0
	D80Q18	Q1	3/4 - 2 11/16"	6.27	5.759	18	13	.557	1.710	2 25/32"	2 1/2"	3/4"	-	4 1/8"	7.3
	D80Q19	Q1	3/4 - 2 11/16"	6.59	6.076	19	13	.557	1.710	2 25/32"	2 1/2"	3/4"	-	4 1/8"	8.5
	D80R20	R1	1 1/8 - 3 3/4"	6.91	6.392	20	12	.557	1.710	3 5/32"	2 7/8"	1 5/32"	-	5 3/8"	7.8
	D80R21	R1	1 1/8 - 3 3/4"	7.24	6.710	21	12	.557	1.710	3 5/32"	2 7/8"	1 5/32"	-	5 3/8"	9.4
	D80R22	R1	1 1/8 - 3 3/4"	7.56	7.027	22	12	.557	1.710	3 5/32"	2 7/8"	1 5/32"	-	5 3/8"	10.8
D80R23	R1	1 1/8 - 3 3/4"	7.88	7.344	23	12	.557	1.710	3 5/32"	2 7/8"	1 5/32"	-	5 3/8"	12.3	
D80R24	R1	1 1/8 - 3 3/4"	8.20	7.661	24	12	.557	1.710	3 5/32"	2 7/8"	1 5/32"	-	5 3/8"	14.1	
D80R25	R1	1 1/8 - 3 3/4"	8.52	7.979	25	12	.557	1.710	3 5/32"	2 7/8"	1 5/32"	-	5 3/8"	15.8	
D80R26	R1	1 1/8 - 3 3/4"	8.84"	8.296"	26	12	.557"	1.710"	3 5/32"	2 7/8"	1 5/32"	-	5 3/8"	18.1	
D80R27	R1	1 1/8 - 3 3/4"	9.16	8.614	27	12	.557	1.710	3 5/32"	2 7/8"	1 5/32"	-	5 3/8"	20.4	
D80R28	R1	1 1/8 - 3 3/4"	9.48	8.931	28	12	.557	1.710	3 5/32"	2 7/8"	1 5/32"	-	5 3/8"	22.7	
D80R30	R1	1 1/8 - 3 3/4"	10.11	9.567	30	12	.557	1.710	3 5/32"	2 7/8"	1 5/32"	-	5 3/8"	26.8	
D80R36	R1	1 1/8 - 3 3/4"	12.03	11.474	36	12	.557	1.710	3 5/32"	2 7/8"	1 5/32"	-	5 3/8"	41.6	
D80R42	R1	1 1/8 - 3 3/4"	13.94	13.382	42	12	.557	1.710	3 5/32"	2 7/8"	1 5/32"	-	5 3/8"	58.0	
D80R45	R1	1 1/8 - 3 3/4"	14.90	14.336	45	12	.557	1.710	3 5/32"	2 7/8"	1 5/32"	-	5 3/8"	68.0	
D80R48	R2	1 3/8 - 3 5/8"	15.86	15.290	48	15	.557	1.710	5 5/32"	4 7/8"	7/8"	29/32"	5 3/8"	86.0	
D80S2	R2	1 3/8 - 3 5/8"	17.13	16.562	52	15	.557	1.710	5 5/32"	4 7/8"	7/8"	29/32"	5 3/8"	103.0	
D80S54	R2	1 3/8 - 3 5/8"	17.77	17.189	54	15	.557	1.710	5 5/32"	4 7/8"	7/8"	29/32"	5 3/8"	111.0	
D80R60	R2	1 3/8 - 3 5/8"	19.64	19.107	60	15	.557	1.710	5 5/32"	4 7/8"	7/8"	29/32"	5 3/8"	135.0	
D80R68	R2	1 3/8 - 3 5/8"	22.23	21.653	68	15	.557	1.710	5 5/32"	4 7/8"	7/8"	29/32"	5 3/8"	176.0	
D80R72	R2	1 3/8 - 3 5/8"	23.46	22.926	72	15	.557	1.710	5 5/32"	4 7/8"	7/8"	29/32"	5 3/8"	198.0	
D80U76	U0	2 3/8 - 5 1/2"	24.74	24.198	76	22	.557	2.863"	5 23/32"	5 1/4"	1 1/2"	21/32"	8 3/8"	219.0	
D80U95	U0	2 3/8 - 5 1/2"	30.83	30.245	95	25	.557	2.863"	5 23/32"	5 1/4"	1 1/2"	21/32"	8 3/8"	342.0	

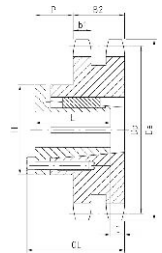

TYPE 12

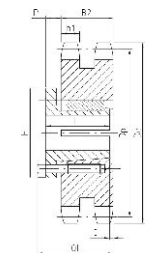

TYPE 13



TYPE 16

- Pitch **1"**  Roller  $\phi$  **0.625"**
- Tooth width b1 **0.575"**  Tooth width B1 **1.710"**  Tooth width B3 **2.863"**

## Triple-Split Taper Bushed

Part Number	Bushing	Bore Range	De	Dp	No. Teeth	Type	b1	B3	OL	L	P	C	H	Wt. Less Bushing	
<b>HARDEN TEETH</b>	T80P13	P2	3/4 - 1 3/4"	4.66	4.179	13	24	.557	2.863	3 3/4"	2 15/16"	5/8"	9/16"	3	5.7
	T80Q14	Q2	1 - 2 5/8"	4.98	4.494	14	27	.557	2.863	5 25/32"	3 1/2"	1 3/4"	2	4 1/8"	7.5
	T80Q15	Q2	1 - 2 5/8"	5.31	4.810	15	22	.557	2.863	4 29/32"	3 1/2"	1 3/4"	1 1/8"	4 1/8"	8.1
	T80Q16	Q2	1 - 2 5/8"	5.63	5.126	16	25	.557	2.863	3 7/8"	3 1/2"	3/4"	3/32"	4 1/8"	9.3
	T80Q17	Q2	1 - 2 5/8"	5.95	5.442	17	24	.557	2.863	3 29/32"	3 1/2"	3/4"	1/8"	4 1/8"	9.8
	T80Q18	Q2	1 - 2 5/8"	6.27	5.759	18	24	.557	2.863	3 29/32"	3 1/2"	3/4"	1/8"	4 1/8"	12.0
	T80Q19	Q2	1 - 2 5/8"	6.59	6.076	19	24	.557	2.863	3 29/32"	3 1/2"	3/4"	1/8"	4 1/8"	13.9
	T80R20	R1	1 1/8 - 3 3/4"	6.91	6.392	20	24	.557	2.863	4 1/32"	2 7/8"	7/8"	7/8"	5 3/8"	10.2
	T80R21	R1	1 1/8 - 3 3/4"	7.24	6.710	21	24	.557	2.863	4 1/32"	2 7/8"	7/8"	7/8"	5 3/8"	12.4
	T80R22	R1	1 1/8 - 3 3/4"	7.56	7.027	22	24	.557	2.863	4 1/32"	2 7/8"	7/8"	7/8"	5 3/8"	14.6
T80R23	R1	1 1/8 - 3 3/4"	7.88	7.344	23	25	.557	2.863	3 5/32"	2 7/8"	0	0	5 3/8"	15.9	
T80R24	R1	1 1/8 - 3 3/4"	8.20	7.661	24	25	.557	2.863	3 5/32"	2 7/8"	0	0	5 3/8"	18.5	
T80R25	R1	1 1/8 - 3 3/4"	8.52	7.979	25	25	.557	2.863	3 5/32"	2 7/8"	0	0	5 3/8"	20.3	
T80R26	R1	1 1/8 - 3 3/4"	8.84	8.296	26	25	.557	2.863	3 5/32"	2 7/8"	0	0	5 3/8"	23.4	
T80R27	R1	1 1/8 - 3 3/4"	9.16	8.614	27	25	.557	2.863	3 5/32"	2 7/8"	0	0	5 3/8"	25.8	
T80R28	R1	1 1/8 - 3 3/4"	9.48	8.931	28	25	.557	2.863	3 5/32"	2 7/8"	0	0	5 3/8"	28.1	
T80R30	R1	1 1/8 - 3 3/4"	10.11	9.567	30	25	.557	2.863	3 5/32"	2 7/8"	0	0	5 3/8"	33.3	
T80S36	S1	1 11/16 - 4 1/4"	12.03	11.474	36	22	.557	2.863	5 1/8"	4 3/8"	1 1/2"	0	6 3/8"	67.0	
T80S42	S1	1 11/16 - 4 1/4"	13.94	13.382	42	22	.557	2.863	5 1/8"	4 3/8"	1 1/2"	0	6 3/8"	96.1	
T80S45	S1	1 11/16 - 4 1/4"	14.90	14.336	45	22	.557	2.863	5 1/8"	4 3/8"	1 1/2"	0	6 3/8"	112	
T80S52	U0	2 3/8 - 5 1/2"	17.13	16.562	52	22	.557	2.863	5 23/32"	5 1/4"	1 25/32"	0	8 3/8"	150	
T80U60	U0	2 3/8 - 5 1/2"	19.68	19.107	60	22	.557	2.863	5 23/32"	5 1/4"	1 25/32"	0	8 3/8"	207	
T80U68	U0	2 3/8 - 5 1/2"	22.23	21.653	68	22	.557	2.863	5 23/32"	5 1/4"	1 25/32"	0	8 3/8"	271	
T80U76	U0	2 3/8 - 5 1/2"	24.78	24.198	76	22	.557	2.863	5 23/32"	5 1/4"	1 25/32"	0	8 3/8"	344	
T80U95	U0	2 3/8 - 5 1/2"	30.83	30.245	95	25	.557	2.863	5 55/32"	5 1/4"	1 13/32"	1/32"	8 3/8"	183	

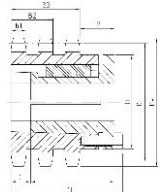

TYPE 22

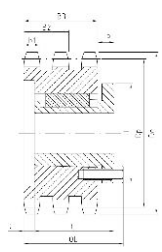

TYPE 24

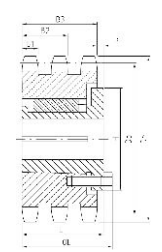

TYPE 25



# No. 100 | Sprockets with Split Taper Bushings

- Pitch **1 1/4"**  Roller  $\phi$  **0.750"**
- Tooth width B1 **0.692"**

## Single-Split Taper Bushed

Part Number	Bushing	Bore Range	De	Dp	No. Teeth	Type	B1	OL	L	P	C	H	Wt. Less Bushing
H100P11	P1	1/2 - 1 3/4	5.01"	4.437"	11	4	.692	2 3/16	1 19/16	1 1/4	0	3"	2.8
H100Q12	OQ1	3/4 - 2 1/16	5.42	4.830	12	4	.692	2 27/32	2 1/2	1 1/8	1/16	4 1/8	3.5
H100Q13	OQ1	3/4 - 2 1/16	5.82	5.223	13	4	.692	2 27/32	2 1/2	1 1/8	1/16	4 1/8	4.3
H100Q14	OQ1	3/4 - 2 1/16	6.23	5.617	14	4	.692	2 25/32	2 1/2	1 13/16	0	4 1/8	5.6
H100Q15	OQ1	3/4 - 2 1/16	6.63	6.012	15	4	.692	2 25/32	2 1/2	1 13/16	0	4 1/8	6.6
<b>HARDEN</b> H100Q16	OQ1	3/4 - 2 1/16	7.03	6.407	16	4	.692	2 25/32	2 1/2	1 13/16	0	4 1/8	7.4
H100Q17	OQ1	3/4 - 2 1/16	7.44	6.803	17	4	.692	2 25/32	2 1/2	1 13/16	0	4 1/8	8.2
H100Q18	OQ1	3/4 - 2 1/16	7.84	7.198	18	4	.692	2 25/32	2 1/2	1 13/16	0	4 1/8	9.0
H100Q19	OQ1	3/4 - 2 1/16	8.24	7.595	19	4	.692	2 25/32	2 1/2	1 13/16	0	4 1/8	9.8
H100Q20	OQ1	3/4 - 2 1/16	8.64	7.991	20	4	.692	2 25/32	2 1/2	1 13/16	0	4 1/8	10.9
H100Q21	OQ1	3/4 - 2 1/16	9.04	8.387	21	4	.692	2 25/32	2 1/2	1 13/16	0	4 1/8	11.8
H100Q22	OQ1	3/4 - 2 1/16	9.44	8.783	22	4	.692	2 25/32	2 1/2	1 13/16	0	4 1/8	12.6
H100Q23	OQ1	3/4 - 2 1/16	9.84	9.180	23	4	.692	2 25/32	2 1/2	1 13/16	0	4 1/8	13.8
H100Q24	OQ1	3/4 - 2 1/16	10.25	9.577	24	4	.692	2 25/32	2 1/2	1 13/16	0	4 1/8	15.4
H100R24	RR1	1 1/8 - 3 3/4	10.25	9.577	24	4	.692	3 5/32	2 7/8	2 3/16	0	5 3/8	15.6
H100Q25	OQ1	3/4 - 2 1/16	10.65	9.973	25	4	.692	2 25/32	2 1/2	1 13/16	0	4 1/8	16.0
H100Q26	OQ1	3/4 - 2 1/16	11.05	10.370	26	4	.692	2 25/32	2 1/2	1 13/16	0	4 1/8	17.3
H100R26	RR1	1 1/8 - 3 3/4	11.05	10.370	26	4	.692	3 5/32	2 7/8	2 3/16	0	5 3/8	17.9
H100R27	RR1	1 1/8 - 3 3/4	11.45	10.767	27	4	.692	3 5/32	2 7/8	2 3/16	0	5 3/8	18.0
H100Q28	OQ1	3/4 - 2 1/16	11.84	11.164	28	4	.692	2 25/32	2 1/2	1 13/16	0	4 1/8	19.6
H100Q30	OQ1	3/4 - 2 1/16	12.64	11.958	30	4	.692	2 25/32	2 1/2	1 13/16	0	4 1/8	22.4
100P11	P1	1/2 - 1 3/4	5.01"	4.437"	11	4	.692	2 3/16	1 19/16	1 1/4	0	3"	3.0
100Q12	OQ1	3/4 - 2 1/16	5.42	4.830	12	4	.692	2 27/32	2 1/2	1 1/8	1/16	4 1/8	3.5
100Q13	OQ1	3/4 - 2 1/16	5.82	5.223	13	4	.692	2 27/32	2 1/2	1 1/8	1/16	4 1/8	4.3
100Q14	OQ1	3/4 - 2 1/16	6.23	5.617	14	4	.692	2 25/32	2 1/2	1 13/16	0	4 1/8	5.6
100Q15	OQ1	3/4 - 2 1/16	6.63	6.012	15	4	.692	2 25/32	2 1/2	1 13/16	0	4 1/8	6.5
100Q16	OQ1	3/4 - 2 1/16	7.03	6.407	16	4	.692	2 25/32	2 1/2	1 13/16	0	4 1/8	7.4
100Q17	OQ1	3/4 - 2 1/16	7.44	6.803	17	4	.692	2 25/32	2 1/2	1 13/16	0	4 1/8	8.2
100Q18	OQ1	3/4 - 2 1/16	7.84	7.198	18	4	.692	2 25/32	2 1/2	1 13/16	0	4 1/8	9.0
100Q19	OQ1	3/4 - 2 1/16	8.24	7.595	19	4	.692	2 25/32	2 1/2	1 13/16	0	4 1/8	9.9
100Q20	OQ1	3/4 - 2 1/16	8.64	7.991	20	4	.692	2 25/32	2 1/2	1 13/16	0	4 1/8	10.8
100Q21	OQ1	3/4 - 2 1/16	9.04	8.387	21	4	.692	2 25/32	2 1/2	1 13/16	0	4 1/8	11.7
100R21	RR1	1 1/8 - 3 3/4	9.04	8.387	21	4	.692	3 5/32	2 7/8	2 3/16	0	5 3/8	13.3
100Q22	OQ1	3/4 - 2 1/16	9.44	8.783	22	4	.692	2 25/32	2 1/2	1 13/16	0	4 1/8	12.5
100Q23	OQ1	3/4 - 2 1/16	9.84	9.180	23	4	.692	2 25/32	2 1/2	1 13/16	0	4 1/8	13.9
100Q24	OQ1	3/4 - 2 1/16	10.25	9.577	24	4	.692	2 25/32	2 1/2	1 13/16	0	4 1/8	15.5
100R24	RR1	1 1/8 - 3 3/4	10.25	9.577	24	4	.692	3 5/32	2 7/8	2 3/16	0	5 3/8	16.1
100Q25	OQ1	3/4 - 2 1/16	10.65	9.973	25	4	.692	2 25/32	2 1/2	1 13/16	0	4 1/8	16.2
100R25	RR1	1 1/8 - 3 3/4	10.65	9.973	25	4	.692	3 5/32	2 7/8	2 3/16	0	5 3/8	17.0
100Q26	OQ1	3/4 - 2 1/16	11.05	10.370	26	4	.692	2 25/32	2 1/2	1 13/16	0	4 1/8	17.9
100R26	RR1	1 1/8 - 3 3/4	11.05	10.370	26	4	.692	3 5/32	2 7/8	2 3/16	0	5 3/8	18.5
100Q27	OQ1	3/4 - 2 1/16	11.45	10.767	27	4	.692	2 25/32	2 1/2	1 13/16	0	4 1/8	18.2
100R27	RR1	1 1/8 - 3 3/4	11.45	10.767	27	4	.692	3 5/32	2 7/8	2 3/16	0	5 3/8	19.6
100Q28	OQ1	3/4 - 2 1/16	11.84	11.164	28	4	.692	2 25/32	2 1/2	1 13/16	0	4 1/8	19.9
100R28	RR1	1 1/8 - 3 3/4	11.84	11.164	28	4	.692	3 5/32	2 7/8	2 3/16	0	5 3/8	21.0
100Q30	OQ1	3/4 - 2 1/16	12.64	11.958	30	4	.692	2 25/32	2 1/2	1 13/16	0	4 1/8	22.6
100R30	RR1	1 1/8 - 3 3/4	12.64	11.958	30	4	.692	3 5/32	2 7/8	2 3/16	0	5 3/8	24.5
100R31	RR1	1 1/8 - 3 3/4	13.04	12.356	31	4	.692	3 5/32	2 7/8	2 3/16	0	5 3/8	25.8
100Q32	OQ1	3/4 - 2 1/16	13.44	12.753	32	4	.692	2 25/32	2 1/2	1 13/16	0	4 1/8	25.3
100R32	RR1	1 1/8 - 3 3/4	13.44	12.753	32	4	.692	3 5/32	2 7/8	2 3/16	0	5 3/8	26.5
100Q35	OQ1	3/4 - 2 1/16	14.64	13.945	35	4	.692	2 25/32	2 1/2	1 13/16	0	4 1/8	30.2
100R35	RR1	1 1/8 - 3 3/4	14.64	13.945	35	4	.692	3 5/32	2 7/8	2 3/16	0	5 3/8	29.8
100R38	RR1	1 1/8 - 3 3/4	15.04	14.342	36	4	.692	3 5/32	2 7/8	2 3/16	0	5 3/8	33.0
100R40	RR1	1 1/8 - 3 3/4	16.63	15.932	40	4	.692	3 5/32	2 7/8	2 3/16	0	5 3/8	40.9
100R42	RR1	1 1/8 - 3 3/4	17.43	16.727	42	4	.692	3 5/32	2 7/8	2 3/16	0	5 3/8	44.3
100R45	RR1	1 1/8 - 3 3/4	18.63	17.920	45	4	.692	3 5/32	2 7/8	2 3/16	0	5 3/8	50.5
100R48	RR1	1 1/8 - 3 3/4	19.82	19.112	48	4	.692	3 5/32	2 7/8	2 3/16	0	5 3/8	57.5
100R54	RR1	1 1/8 - 3 3/4	22.21	21.498	54	5	.692	3 5/32	2 7/8	7/8	1 5/16	5 3/8	69.0
100R60	RR1	1 1/8 - 3 3/4	24.55	23.884	60	5	.692	3 5/32	2 7/8	7/8	1 5/16	5 3/8	84.0
100R70	RR1	1 1/8 - 3 3/4	29.33	27.862	70	5	.692	3 5/32	2 7/8	7/8	1 5/16	5 3/8	104.0
100R72	RR1	1 1/8 - 3 3/4	29.33	28.657	72	5	.692	3 5/32	2 7/8	7/8	1 5/16	5 3/8	106.0
100R80	RR1	1 1/8 - 3 3/4	32.52	31.839	80	5	.692	3 5/32	2 7/8	7/8	1 5/16	5 3/8	135.0
100R84	RR1	1 1/8 - 3 3/4	34.11	33.430	84	5	.692	3 5/32	2 7/8	7/8	1 5/16	5 3/8	138.0

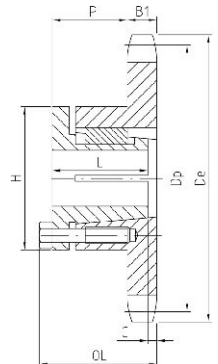

TYPE 4

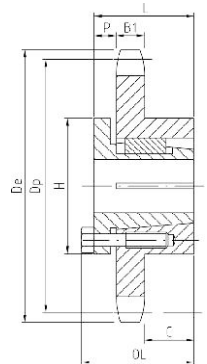

TYPE 5

Sprockets

# No.100-2

# No.120 | Sprockets with Split Taper Bushings



- Pitch **1 1/4"**  Roller  $\phi$  **0.750"**
- Tooth width b1 **0.669"**  Tooth width B2 **2.077"**

## Double-Split Taper Bushed

Part Number	Bushing	Bore Range	De	Dp	No. Teeth	Type	b1	B2	OL	L	P	C	H	Wt. Less Bushing	
<b>HARDEN TEETH</b>	D100P11	P1	1/2 - 1 3/4	5.01	4.437	11	14	.669	2.077	2 15/16	1 15/16	5/8	3/4	3	4.7
	D100Q12	Q2	1 - 2 3/8	5.42	4.830	12	12	.669	2.077	4 7/32	3 1/2	1 55/64	7/16	4 1/8	5.9
	D100Q13	Q2	1 - 2 3/8	5.82	5.223	13	12	.669	2.077	4 7/32	3 1/2	1 55/64	7/16	4 1/8	7.9
	D100Q14	Q1	3/4 - 2 11/16	6.23	5.617	14	14	.669	2.077	3 3/32	2 1/2	2 3/4	5/16	4 1/8	7.4
<b>HARDEN TEETH</b>	D100Q15	Q1	3/4 - 2 11/16	6.63	6.012	15	14	.669	2.077	3 3/32	2 1/2	3/4	5/16	4 1/8	9.1
	D100Q16	Q1	3/4 - 2 11/16	7.03	6.407	16	14	.669	2.077	3 3/32	2 1/2	3/4	5/16	4 1/8	10.9
	D100R17	R1	1 1/8 - 3 3/4	7.44	6.803	17	14	.669	2.077	3 7/32	2 7/8	7/8	1/16	5 3/8	10.0
	D100R18	R1	1 1/8 - 3 3/4	7.84	7.198	18	14	.669	2.077	3 7/32	2 7/8	7/8	1/16	5 3/8	12.3
<b>HARDEN TEETH</b>	D100R19	R1	1 1/8 - 3 3/4	8.24	7.595	19	14	.669	2.077	3 7/32	2 7/8	7/8	1/16	5 3/8	14.9
	D100R20	RR1	1 1/8 - 3 3/4	8.64	7.991	20	14	.669	2.077	3 7/32	2 7/8	7/8	1/16	5 3/8	17.4
	D100R21	RR1	1 1/8 - 3 3/4	9.04	8.387	21	14	.669	2.077	3 7/32	2 7/8	7/8	1/16	5 3/8	20.3
	D100R22	RR1	1 1/8 - 3 3/4	9.44	8.783	22	14	.669	2.077	3 7/32	2 7/8	7/8	1/16	5 3/8	22.8
D100R24	R1	1 1/8 - 3 3/4	10.25	9.577	24	14	.669	2.077	3 7/32	2 7/8	7/8	1/16	5 3/8	29.5	
<b>HARDEN TEETH</b>	D100R35	R1	1 1/8 - 3 3/4	14.64	13.945	35	14	.669	2.077	3 7/32	2 7/8	7/8	1/16	5 3/8	76.8
	D100S45	S1	1 11/16 - 4 1/4	18.63	17.920	45	15	.669	2.077	4 3/4	4 3/4	1 1/16	1 15/64	6 3/8	138.0
	D100S60	S1	1 11/16 - 4 1/4	24.60	23.884	60	15	.669	2.077	4 3/4	4 3/4	1 1/16	1 15/64	6 3/8	251.0
	D100S70	S1	1 11/16 - 4 1/4	28.58	27.862	70	18	.669	2.077	7 1/8	6 3/4	2 7/16	2 1/4	6 3/8	358.0
	D100S80	S1	1 11/16 - 4 1/4	32.57	31.839	80	18	.669	2.077	7 1/8	6 1/16	2 7/16	2 1/4	6 3/8	431.0

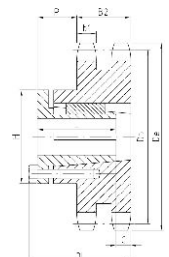

TYPE 12

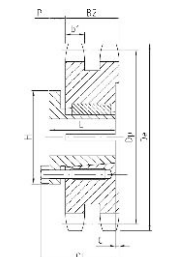

TYPE 14

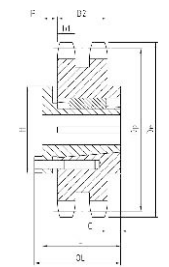

TYPE 15

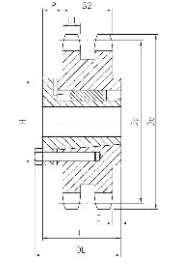

TYPE 18

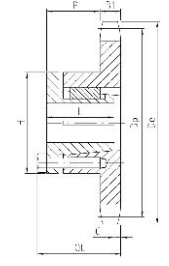

TYPE 4

- Pitch **1 1/2"**  Roller  $\phi$  **0.875"**
- Tooth width B1 **0.924"**

## Single-Split Taper Bushed

Part Number	Bushing	Bore Range	De	Dp	No. Teeth	Type	B1	OL	L	P	C	H	Wt. Less Bushing	
<b>HARDEN TEETH</b>	H120Q11	Q1	3/4 - 2 11/16	6.01	5.324	11	4	.924	2 25/32	2 1/2	1 9/16	0	4 1/8	4.8
	H120Q12	Q1	3/4 - 2 11/16	6.50	5.796	12	4	.924	2 25/32	2 1/2	1 9/16	0	4 1/8	6.3
	H120Q13	Q1	3/4 - 2 11/16	6.99	6.268	13	4	.924	2 25/32	2 1/2	1 9/16	0	4 1/8	7.9
	H120Q14	Q1	3/4 - 2 11/16	7.47	6.741	14	4	.924	2 25/32	2 1/2	1 9/16	0	4 1/8	9.2
<b>HARDEN TEETH</b>	H120Q15	Q1	3/4 - 2 11/16	7.96	7.215	15	4	.924	2 25/32	2 1/2	1 9/16	0	4 1/8	10.4
	H120R16	RR1	1 1/8 - 3 3/4	8.39	7.689	16	4	.924	3 3/32	2 7/8	1 15/16	0	5 3/8	12.0
	H120R17	RR1	1 1/8 - 3 3/4	8.88	8.163	17	4	.924	3 3/32	2 7/8	1 15/16	0	5 3/8	13.7
	H120R18	R1	1 1/8 - 3 3/4	9.41	8.638	18	4	.924	3 3/32	2 7/8	1 15/16	0	5 3/8	15.0
<b>HARDEN TEETH</b>	H120R19	RR1	1 1/8 - 3 3/4	9.89	9.113	19	4	.924	3 3/32	2 7/8	1 15/16	0	5 3/8	16.9
	H120R20	RR1	1 1/8 - 3 3/4	10.37	9.589	20	4	.924	3 3/32	2 7/8	1 15/16	0	5 3/8	18.8
	H120R21	RR1	1 1/8 - 3 3/4	10.85	10.064	21	4	.924	3 3/32	2 7/8	1 15/16	0	5 3/8	20.7
	H120R22	R1	1 1/8 - 3 3/4	11.33	10.540	22	4	.924	3 3/32	2 7/8	1 15/16	0	5 3/8	22.5
H120R23	R1	1 1/8 - 3 3/4	11.81	11.016	23	4	.924	3 3/32	2 7/8	1 15/16	0	5 3/8	24.3	
<b>HARDEN TEETH</b>	H120R24	R1	1 1/8 - 3 3/4	12.29	11.492	24	4	.924	3 3/32	2 7/8	1 15/16	0	5 3/8	27.1
	H120R25	R1	1 1/8 - 3 3/4	12.77	11.968	25	4	.924	3 3/32	2 7/8	1 15/16	0	5 3/8	29.1
	H120R26	R1	1 1/8 - 3 3/4	13.25	12.444	26	5	.924	3 3/32	2 7/8	7/8	1/16	5 3/8	33.3
	H120R28	R1	1 1/8 - 3 3/4	14.21	13.397	28	5	.924	3 3/32	2 7/8	7/8	1/16	5 3/8	38.0
	H120R30	R1	1 1/8 - 3 3/4	15.17	14.350	30	5	.924	3 3/32	2 7/8	7/8	1/16	5 3/8	43.3

Sprockets

# No.120

# No.120-2 | Sprockets with Split Taper Bushings



- Pitch **1 1/2"**
- Roller  $\phi$  **0.875"**
- Tooth width B1 **0.924"**

## Single-Split Taper Bushed

Part Number	Bushing	Bore Range	De	Dp	No. Teeth	Type	B1	OL	L	P	C	H	Wt. Less Bushing
120Q11	Q1	3/4 - 2 11/16	6.01	5.324	11	4	.924	2 25/32	2 1/2	1 9/16	0	4 1/8	4.8
120Q12	Q1	3/4 - 2 11/16	6.50	5.796	12	4	.924	2 25/32	2 1/2	1 9/16	0	4 1/8	6.3
120Q13	Q1	3/4 - 2 11/16	6.99	6.268	13	4	.924	2 25/32	2 1/2	1 9/16	0	4 1/8	7.9
120Q14	Q1	3/4 - 2 11/16	7.47	6.741	14	4	.924	2 25/32	2 1/2	1 9/16	0	4 1/8	9.1
120Q15	Q1	3/4 - 2 11/16	7.96	7.215	15	4	.924	2 25/32	2 1/2	1 9/16	0	4 1/8	10.4
120Q16	Q1	3/4 - 2 11/16	8.39	7.689	16	4	.924	2 25/32	2 1/2	1 9/16	0	4 1/8	11.8
120R16	R1	1 1/8 - 3 3/4	8.89	7.689	16	4	.924	3 5/32	2 7/8	1 9/16	0	5 3/8	12.3
120Q17	Q1	3/4 - 2 11/16	8.88	8.163	17	4	.924	2 25/32	2 1/2	1 9/16	0	4 1/8	13.4
120R17	R1	1 1/8 - 3 3/4	8.88	8.163	17	4	.924	3 5/32	2 7/8	1 9/16	0	5 3/8	13.6
120Q18	Q1	3/4 - 2 11/16	9.41	8.638	18	4	.924	2 25/32	2 1/2	1 9/16	0	4 1/8	15.6
120R18	R1	1 1/8 - 3 3/4	9.41	8.638	18	4	.924	3 5/32	3 5/32	1 9/16	0	5 3/8	15.9
120R19	R1	1 1/8 - 3 3/4	9.89	9.113	19	4	.924	3 5/32	3 5/32	1 9/16	0	5 3/8	16.8
120R20	R1	1 1/8 - 3 3/4	10.37	9.589	20	4	.924	3 5/32	2 7/8	1 9/16	0	5 3/8	18.8
120R21	R1	1 1/8 - 3 3/4	10.85	10.064	21	4	.924	3 5/32	2 7/8	1 9/16	0	5 3/8	21.0
120R22	R1	1 1/8 - 3 3/4	11.33	10.540	22	4	.924	3 5/32	2 7/8	1 9/16	0	5 3/8	22.5
120R23	R1	1 1/8 - 3 3/4	11.81	11.016	23	4	.924	3 5/32	2 7/8	1 9/16	0	5 3/8	24.8
120R24	R1	1 1/8 - 3 3/4	12.29	11.492	24	4	.924	3 5/32	2 7/8	1 9/16	0	5 3/8	26.9
120R25	R1	1 1/8 - 3 3/4	12.77	11.968	25	4	.924	3 5/32	2 7/8	1 9/16	0	5 3/8	29.8
120R26	R1	1 1/8 - 3 3/4	13.25	12.444	26	5	.924	3 5/32	2 7/8	7/8	1 1/16	5 3/8	32.9
120R28	R1	1 1/8 - 3 3/4	14.21	13.397	28	5	.924	3 5/32	2 7/8	7/8	1 1/16	5 3/8	38.3
120R30	R1	1 1/8 - 3 3/4	15.17	14.350	30	5	.924	3 5/32	2 7/8	7/8	1 1/16	5 3/8	43.4
120R32	R1	1 1/8 - 3 3/4	16.13	15.303	32	5	.924	3 5/32	2 7/8	7/8	1 1/16	5 3/8	49.4
120R35	R2	1 3/8 - 3 5/8	17.57	16.734	35	6	.924	5 5/32	4 7/8	1 15/16	2	5 3/8	68.0
120R36	R2	1 3/8 - 3 5/8	18.05	17.211	36	6	.924	5 5/32	4 7/8	1 15/16	2	5 3/8	72.0
120R40	R2	1 3/8 - 3 5/8	19.96	19.118	40	6	.924	5 5/32	4 7/8	1 15/16	2	5 3/8	82.0
120S40	S1	1 11/16 - 4 1/4	19.96	19.118	40	5	.924	4 3/4	4 3/8	1 1/16	2 3/8	6 3/8	83.0
120S42	S1	1 11/16 - 4 1/4	20.92	20.072	42	5	.924	4 3/4	4 3/8	1 1/16	2 3/8	6 3/8	90.0
120R45	R2	1 3/8 - 3 5/8	22.35	21.503	45	6	.924	5 5/32	4 7/8	1 15/16	2	5 3/8	102.0
120S45	S1	1 11/16 - 4 1/4	22.35	21.503	45	5	.924	4 3/4	4 3/8	1 1/16	2 3/8	6 3/8	100.0
120S48	S1	1 11/16 - 4 1/4	23.79	22.935	48	5	.924	4 3/4	4 3/8	1 1/16	2 3/8	6 3/8	111.0
120S54	S1	1 11/16 - 4 1/4	26.65	25.798	54	5	.924	4 3/4	4 3/8	1 1/16	2 3/8	6 3/8	138.0
120R60	R2	1 3/8 - 3 5/8	29.52	28.661	60	6	.924	5 5/32	4 7/8	1 15/16	2	5 3/8	179.0
120S60	S1	1 11/16 - 4 1/4	29.52	28.661	60	5	.924	4 3/4	4 3/8	1 1/16	2 3/8	6 3/8	180.0
120R70	R2	1 3/8 - 3 5/8	34.30	33.434	70	6	.924	5 5/32	4 7/8	1 15/16	2	5 3/8	148.0
120S70	S2	1 7/8 - 4 3/16	34.30	33.434	70	5	.924	7 1/8	6 3/4	2 15/16	2 7/8	6 3/8	167.0
120R80	R2	1 3/8 - 3 5/8	39.08	38.207	80	6	.924	5 5/32	4 7/8	1 15/16	2	5 3/8	291.0
120S80	S2	1 7/8 - 4 3/16	39.08	38.207	80	6	.924	7 1/8	6 3/4	2 15/16	2 7/8	6 3/8	305.0

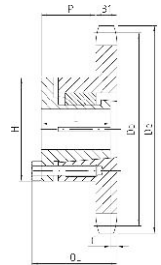

TYPE 4

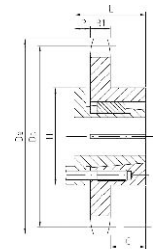

TYPE 5

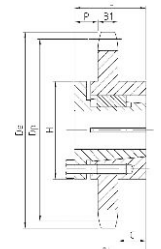

TYPE 6

- Pitch **1 1/2"**
- Roller  $\phi$  **0.875"**
- Tooth width b1 **0.894"**
- Tooth width B2 **2.683"**

## Double-Split Taper Bushed

Part Number	Bushing	Bore Range	De	Dp	Type	No. Teeth	b1	B2	OL	L	P	C	H	Wt. Less Bushing
D120S30	S1	1 11/16 - 4 1/4	15.17	14.350	15	30	.894	2.683	4 3/4	4 3/8	1 1/16	5/8	6 3/8	105
D120S35	S2	1 11/16 - 4 1/4	17.57	16.734	15	35	.894	2.683	4 3/4	4 3/8	1 1/16	5/8	6 3/8	148
D120S45	S2	1 7/8 - 4 3/16	22.35	21.503	18	45	.894	2.683	7 1/8	6 3/4	2 7/32	1 27/32	6 3/8	268
D120U60	U0	2 3/8 - 5 1/2	29.52	28.661	15	60	.894	2.683	5 23/32	5 1/4	1 19/32	1 9/32	8 3/8	183

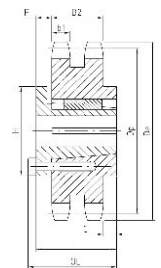

TYPE 15

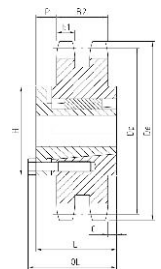

TYPE 16

Sprockets



**GOODWILL**

# No.140 | Sprockets with Split Taper Bushings

- Pitch **1<sup>3</sup>/<sub>4</sub>"**
- Roller  $\phi$  **1.000"**
- Tooth width b1 **0.924"**

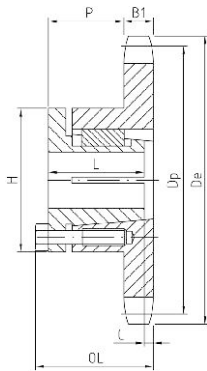

**TYPE 4**

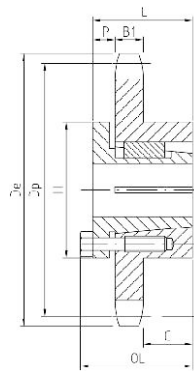

**TYPE 5**

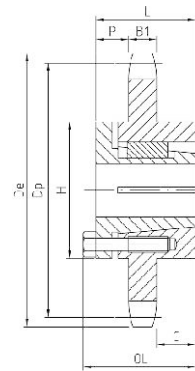

**TYPE 6**

## Single-Split Taper Bushed

Part Number	Bushing	Bore Range	De	Dp	No. Teeth	Type	b1	OL	L	P	C	H	Wt. Less Bushing	
<b>HARDEN TEETH</b>	H140Q11	Q1	3/4 - 2 11/16"	7.01"	6.212"	11	4	.924"	2 <sup>25</sup> / <sub>32</sub> "	2 1/2"	1 9/16"	0	4 1/8"	6.4
	H140Q12	Q1	3/4 - 2 11/16"	7.58	6.762	12	4	.924	2 <sup>25</sup> / <sub>32</sub> "	2 1/2"	1 9/16"	0	4 1/8"	9.0
	H140R13	R1	1 1/8 - 3 3/4"	8.15	7.313	13	4	.924	3 5/32"	2 7/8"	1 15/16"	0	5 3/8"	11.1
	H140R14	R1	1 1/8 - 3 3/4"	8.72	7.864	14	4	.924	3 5/32"	2 7/8"	1 15/16"	0	5 3/8"	12.6
	H140R15	R1	1 1/8 - 3 3/4"	9.28	8.417	15	4	.924	3 5/32"	2 7/8"	1 15/16"	0	5 3/8"	14.7
	H140R16	R1	1 1/8 - 3 3/4"	9.85	8.970	16	4	.924	3 5/32"	2 7/8"	1 15/16"	0	5 3/8"	16.5
	H140R17	R1	1 1/8 - 3 3/4"	10.41	9.524	17	4	.924	3 5/32"	2 7/8"	1 15/16"	0	5 3/8"	18.5
	H140R18	R1	1 1/8 - 3 3/4"	10.97	10.078	18	4	.924	3 5/32"	2 7/8"	1 15/16"	0	5 3/8"	20.5
	H140R19	R1	1 1/8 - 3 3/4"	11.54	10.632	19	4	.924	3 5/32"	2 7/8"	1 15/16"	0	5 3/8"	23.0
	H140R20	R1	1 1/8 - 3 3/4"	12.10	11.187	20	4	.924	3 5/32"	2 7/8"	1 15/16"	0	5 3/8"	25.4
	H140R21	R1	1 1/8 - 3 3/4"	12.66	11.742	21	4	.924	3 5/32"	2 7/8"	1 15/16"	0	5 3/8"	27.8
	H140R22	R1	1 1/8 - 3 3/4"	13.22	12.297	22	5	.924	3 5/32"	2 7/8"	7/8"	1 1/16"	5 3/8"	32.5
	H140R23	R1	1 1/8 - 3 3/4"	13.78	12.852	23	5	.924	3 5/32"	2 7/8"	7/8"	1 1/16"	5 3/8"	36.0
	H140R24	R1	1 1/8 - 3 3/4"	14.34	13.407	24	5	.924	3 5/32"	2 7/8"	7/8"	1 1/16"	5 3/8"	37.6
	H140R25	R1	1 1/8 - 3 3/4"	14.90	13.963	25	5	.924	3 5/32"	2 7/8"	7/8"	1 1/16"	5 3/8"	40.3
	H140R26	R1	1 1/8 - 3 3/4"	15.46	14.513	26	5	.924	3 5/32"	2 7/8"	7/8"	1 1/16"	5 3/8"	44.0
	H140R30	R2	1 3/8 - 3 5/8"	17.70	16.742	30	5	.924	5 5/32"	4 7/8"	7/8"	2	5 3/8"	68.0
	140Q11	Q1	3/4 - 2 11/16"	7.01"	6.212"	11	4	.924"	2 <sup>25</sup> / <sub>32</sub> "	2 1/2"	1 9/16"	0	4 1/8"	6.4
	140Q12	Q1	3/4 - 2 11/16"	7.58	6.762	12	4	.924	2 <sup>25</sup> / <sub>32</sub> "	2 1/2"	1 9/16"	0	4 1/8"	9.0
	140R13	R1	1 1/8 - 3 3/4"	8.15	7.313	13	4	.924	3 5/32"	2 7/8"	1 15/16"	0	5 3/8"	11.1
	140R14	R1	1 1/8 - 3 3/4"	8.72	7.864	14	4	.924	3 5/32"	2 7/8"	1 15/16"	0	5 3/8"	12.6
	140R15	R1	1 1/8 - 3 3/4"	9.28	8.417	15	4	.924	3 5/32"	2 7/8"	1 15/16"	0	5 3/8"	14.7
	140R16	R1	1 1/8 - 3 3/4"	9.85	8.970	16	4	.924	3 5/32"	2 7/8"	1 15/16"	0	5 3/8"	16.5
	140R17	R1	1 1/8 - 3 3/4"	10.41	9.524	17	4	.924	3 5/32"	2 7/8"	1 15/16"	0	5 3/8"	18.5
	140R18	R1	1 1/8 - 3 3/4"	10.97	10.078	18	4	.924	3 5/32"	2 7/8"	1 15/16"	0	5 3/8"	20.5
	140R19	R1	1 1/8 - 3 3/4"	11.54	10.632	19	4	.924	3 5/32"	2 7/8"	1 15/16"	0	5 3/8"	23.0
	140R20	R1	1 1/8 - 3 3/4"	12.10	11.187	20	4	.924	3 5/32"	2 7/8"	1 15/16"	0	5 3/8"	25.4
	140R21	R1	1 1/8 - 3 3/4"	12.66	11.742	21	4	.924	3 5/32"	2 7/8"	1 15/16"	0	5 3/8"	27.8
	140R22	R1	1 1/8 - 3 3/4"	13.22	12.297	22	5	.924	3 5/32"	2 7/8"	7/8"	1 1/16"	5 3/8"	32.5
	140R23	R1	1 1/8 - 3 3/4"	13.78	12.852	23	5	.924	3 5/32"	2 7/8"	7/8"	1 1/16"	5 3/8"	36.0
140R24	R1	1 1/8 - 3 3/4"	14.34	13.407	24	5	.924	3 5/32"	2 7/8"	7/8"	1 1/16"	5 3/8"	37.6	
140R25	R1	1 1/8 - 3 3/4"	14.90	13.963	25	5	.924	3 5/32"	2 7/8"	7/8"	1 1/16"	5 3/8"	40.3	
140R26	R1	1 1/8 - 3 3/4"	15.46	14.513	26	5	.924	3 5/32"	2 7/8"	7/8"	1 1/16"	5 3/8"	44.0	
140R30	R2	1 3/8 - 3 5/8"	17.70	16.742	30	6	.924	5 5/32"	4 7/8"	7/8"	2	5 3/8"	68.0	
140R35	R2	1 3/8 - 3 5/8"	20.49	19.523	35	6	.924	5 5/32"	4 7/8"	7/8"	2	5 3/8"	88.0	
140R36	R2	1 3/8 - 3 5/8"	21.05	20.079	36	6	.924	5 5/32"	4 7/8"	7/8"	2	5 3/8"	90.0	
140S36	S1	1 11/16 - 4 1/4"	21.05	20.079	36	5	.924	4 3/4"	4 3/8"	1 1/16"	2 3/8"	6 3/8"	89.0	
140S40	R2	1 3/8 - 3 5/8"	23.29	22.305	40	6	.924	5 5/32"	4 7/8"	7/8"	2	5 3/8"	109.0	
140S40	S1	1 11/16 - 4 1/4"	23.29	22.305	40	5	.924	4 3/4"	4 3/8"	1 1/16"	2 3/8"	6 3/8"	107.0	
140S45	S1	1 11/16 - 4 1/4"	26.08	25.087	45	5	.924	4 3/4"	4 3/8"	1 1/16"	2 3/8"	6 3/8"	132.0	
140S48	S2	1 7/8 - 4 3/16"	27.75	26.757	48	6	.924	7 1/2"	6 3/4"	2 15/16"	2 7/8"	6 3/8"	169.0	
140S54	S2	1 7/8 - 4 3/16"	31.10	30.097	54	6	.924	7 1/2"	6 3/4"	2 15/16"	2 7/8"	6 3/8"	208.0	
140S60	S2	1 7/8 - 4 3/16"	34.44	33.438	60	6	.924	7 1/2"	6 3/4"	2 15/16"	2 7/8"	6 3/8"	230.0	
140S70	S2	1 7/8 - 4 3/16"	40.02	39.006	70	6	.924	7 1/2"	6 3/4"	2 15/16"	2 7/8"	6 3/8"	311.0	
140S80	S2	1 7/8 - 4 3/16"	45.59	44.575	80	6	.924	7 1/2"	6 3/4"	2 15/16"	2 7/8"	6 3/8"	242.0	

Sprockets



**GOODWILL**

# No. 160 | Sprockets with Split Taper Bushings

- Pitch 2"
- Roller  $\phi$  1.125"
- Tooth width B1 1.156"

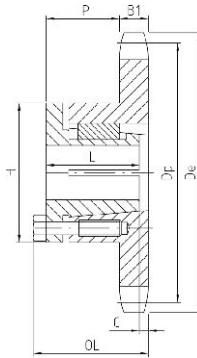

TYPE 4

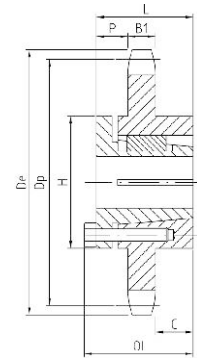

TYPE 6

## Single-Split Taper Bushed

Part Number	Bushing	Bore Range	De	Dp	No. Teeth	Type	B1	OL	L	P	C	H	Wt. Less Bushing	
<b>HARDEN TEETH</b>	H160R11	R1	1 <sup>1</sup> / <sub>8</sub> - 3 <sup>3</sup> / <sub>4</sub> "	8.01"	7.099"	11	4	1.156"	3 <sup>13</sup> / <sub>32</sub> "	2 <sup>7</sup> / <sub>8</sub> "	1 <sup>31</sup> / <sub>32</sub> "	1 <sup>1</sup> / <sub>4</sub> "	5 <sup>3</sup> / <sub>8</sub> "	10.8
	H160R12	R1	1 <sup>1</sup> / <sub>8</sub> - 3 <sup>3</sup> / <sub>4</sub> "	8.66	7.727	12	4	1.156	3 <sup>13</sup> / <sub>32</sub> "	2 <sup>7</sup> / <sub>8</sub> "	1 <sup>31</sup> / <sub>32</sub> "	1 <sup>1</sup> / <sub>4</sub> "	5 <sup>3</sup> / <sub>8</sub> "	14.2
	H160R13	R1	1 <sup>1</sup> / <sub>8</sub> - 3 <sup>3</sup> / <sub>4</sub> "	9.31	8.357	13	4	1.156	3 <sup>5</sup> / <sub>32</sub> "	2 <sup>7</sup> / <sub>8</sub> "	1 <sup>23</sup> / <sub>32</sub> "	0	5 <sup>3</sup> / <sub>8</sub> "	15.5
	H160R14	R1	1 <sup>1</sup> / <sub>8</sub> - 3 <sup>3</sup> / <sub>4</sub> "	9.96	8.988	14	4	1.156	3 <sup>5</sup> / <sub>32</sub> "	2 <sup>7</sup> / <sub>8</sub> "	1 <sup>23</sup> / <sub>32</sub> "	0	5 <sup>3</sup> / <sub>8</sub> "	18.5
	H160R15	R1	1 <sup>1</sup> / <sub>8</sub> - 3 <sup>3</sup> / <sub>4</sub> "	10.61	9.620	15	4	1.156	3 <sup>5</sup> / <sub>32</sub> "	2 <sup>7</sup> / <sub>8</sub> "	1 <sup>23</sup> / <sub>32</sub> "	0	5 <sup>3</sup> / <sub>8</sub> "	21.6
	H140R16	R1	1 <sup>1</sup> / <sub>8</sub> - 3 <sup>3</sup> / <sub>4</sub> "	11.25	10.252	16	4	1.156	3 <sup>5</sup> / <sub>32</sub> "	2 <sup>7</sup> / <sub>8</sub> "	1 <sup>23</sup> / <sub>32</sub> "	0	5 <sup>3</sup> / <sub>8</sub> "	25.0
	H160R17	R1	1 <sup>1</sup> / <sub>8</sub> - 3 <sup>3</sup> / <sub>4</sub> "	11.90	10.885	17	4	1.156	3 <sup>5</sup> / <sub>32</sub> "	2 <sup>7</sup> / <sub>8</sub> "	1 <sup>23</sup> / <sub>32</sub> "	0	5 <sup>3</sup> / <sub>8</sub> "	28.0
	H160R18	R1	1 <sup>1</sup> / <sub>8</sub> - 3 <sup>3</sup> / <sub>4</sub> "	12.54	11.518	18	4	1.156	3 <sup>5</sup> / <sub>32</sub> "	2 <sup>7</sup> / <sub>8</sub> "	1 <sup>23</sup> / <sub>32</sub> "	0	5 <sup>3</sup> / <sub>8</sub> "	31.9
	H160R19	R1	1 <sup>1</sup> / <sub>8</sub> - 3 <sup>3</sup> / <sub>4</sub> "	13.19	12.151	19	4	1.156	3 <sup>5</sup> / <sub>32</sub> "	2 <sup>7</sup> / <sub>8</sub> "	1 <sup>23</sup> / <sub>32</sub> "	0	5 <sup>3</sup> / <sub>8</sub> "	35.9
	H160R20	R2	1 <sup>3</sup> / <sub>8</sub> - 3 <sup>5</sup> / <sub>8</sub> "	13.83	12.785	20	6	1.156	5 <sup>5</sup> / <sub>32</sub> "	4 <sup>7</sup> / <sub>8</sub> "	1 <sup>23</sup> / <sub>32</sub> "	2	5 <sup>3</sup> / <sub>8</sub> "	51.0
	H160R21	R2	1 <sup>3</sup> / <sub>8</sub> - 3 <sup>5</sup> / <sub>8</sub> "	14.47	13.419	21	6	1.156	5 <sup>5</sup> / <sub>32</sub> "	4 <sup>7</sup> / <sub>8</sub> "	1 <sup>23</sup> / <sub>32</sub> "	2	5 <sup>3</sup> / <sub>8</sub> "	56.0
	H160R22	R2	1 <sup>3</sup> / <sub>8</sub> - 3 <sup>5</sup> / <sub>8</sub> "	15.11	14.053	22	6	1.156	5 <sup>5</sup> / <sub>32</sub> "	4 <sup>7</sup> / <sub>8</sub> "	1 <sup>23</sup> / <sub>32</sub> "	2	5 <sup>3</sup> / <sub>8</sub> "	60.0
	H160R23	R2	1 <sup>3</sup> / <sub>8</sub> - 3 <sup>5</sup> / <sub>8</sub> "	15.75	14.688	23	6	1.156	5 <sup>5</sup> / <sub>32</sub> "	4 <sup>7</sup> / <sub>8</sub> "	1 <sup>23</sup> / <sub>32</sub> "	2	5 <sup>3</sup> / <sub>8</sub> "	65.0
	H160R24	R2	1 <sup>3</sup> / <sub>8</sub> - 3 <sup>5</sup> / <sub>8</sub> "	16.39	15.323	24	6	1.156	5 <sup>5</sup> / <sub>32</sub> "	4 <sup>7</sup> / <sub>8</sub> "	1 <sup>23</sup> / <sub>32</sub> "	2	5 <sup>3</sup> / <sub>8</sub> "	71.5
	H160R25	R2	1 <sup>3</sup> / <sub>8</sub> - 3 <sup>5</sup> / <sub>8</sub> "	17.03	15.958	25	6	1.156	5 <sup>5</sup> / <sub>32</sub> "	4 <sup>7</sup> / <sub>8</sub> "	1 <sup>23</sup> / <sub>32</sub> "	2	5 <sup>3</sup> / <sub>8</sub> "	74.0
	H160S26	S2	1 <sup>7</sup> / <sub>8</sub> - 4 <sup>3</sup> / <sub>16</sub> "	17.67	16.593	26	6	1.156	7 <sup>1</sup> / <sub>8</sub> "	6 <sup>3</sup> / <sub>4</sub> "	2 <sup>23</sup> / <sub>32</sub> "	2 <sup>2</sup> / <sub>8</sub> "	6 <sup>3</sup> / <sub>8</sub> "	79.0
	H160S28	S2	1 <sup>7</sup> / <sub>8</sub> - 4 <sup>3</sup> / <sub>16</sub> "	18.95	17.863	28	6	1.156	7 <sup>1</sup> / <sub>8</sub> "	6 <sup>3</sup> / <sub>4</sub> "	2 <sup>23</sup> / <sub>32</sub> "	2 <sup>2</sup> / <sub>8</sub> "	6 <sup>3</sup> / <sub>8</sub> "	99.8
	H160S30	S2	1 <sup>7</sup> / <sub>8</sub> - 4 <sup>3</sup> / <sub>16</sub> "	20.23	19.134	30	6	1.156	7 <sup>1</sup> / <sub>8</sub> "	6 <sup>3</sup> / <sub>4</sub> "	2 <sup>23</sup> / <sub>32</sub> "	2 <sup>2</sup> / <sub>8</sub> "	6 <sup>3</sup> / <sub>8</sub> "	115
	160R11	R1	1 <sup>1</sup> / <sub>8</sub> - 3 <sup>3</sup> / <sub>4</sub> "	8.01"	7.099"	11	4	1.156"	3 <sup>13</sup> / <sub>32</sub> "	2 <sup>7</sup> / <sub>8</sub> "	1 <sup>31</sup> / <sub>32</sub> "	1 <sup>1</sup> / <sub>4</sub> "	5 <sup>3</sup> / <sub>8</sub> "	10.8
	160R12	R1	1 <sup>1</sup> / <sub>8</sub> - 3 <sup>3</sup> / <sub>4</sub> "	8.66	7.727	12	4	1.156	3 <sup>13</sup> / <sub>32</sub> "	2 <sup>7</sup> / <sub>8</sub> "	1 <sup>31</sup> / <sub>32</sub> "	1 <sup>1</sup> / <sub>4</sub> "	5 <sup>3</sup> / <sub>8</sub> "	14.2
160R13	R1	1 <sup>1</sup> / <sub>8</sub> - 3 <sup>3</sup> / <sub>4</sub> "	9.31	8.357	13	4	1.156	3 <sup>5</sup> / <sub>32</sub> "	2 <sup>7</sup> / <sub>8</sub> "	1 <sup>23</sup> / <sub>32</sub> "	0	5 <sup>3</sup> / <sub>8</sub> "	15.5	
160R14	R1	1 <sup>1</sup> / <sub>8</sub> - 3 <sup>3</sup> / <sub>4</sub> "	9.96	8.988	14	4	1.156	3 <sup>5</sup> / <sub>32</sub> "	2 <sup>7</sup> / <sub>8</sub> "	1 <sup>23</sup> / <sub>32</sub> "	0	5 <sup>3</sup> / <sub>8</sub> "	18.5	
160R15	R1	1 <sup>1</sup> / <sub>8</sub> - 3 <sup>3</sup> / <sub>4</sub> "	10.61	9.620	15	4	1.156	3 <sup>5</sup> / <sub>32</sub> "	2 <sup>7</sup> / <sub>8</sub> "	1 <sup>23</sup> / <sub>32</sub> "	0	5 <sup>3</sup> / <sub>8</sub> "	21.6	
160R16	R1	1 <sup>1</sup> / <sub>8</sub> - 3 <sup>3</sup> / <sub>4</sub> "	11.25	10.252	16	4	1.156	3 <sup>5</sup> / <sub>32</sub> "	2 <sup>7</sup> / <sub>8</sub> "	1 <sup>23</sup> / <sub>32</sub> "	0	5 <sup>3</sup> / <sub>8</sub> "	25.0	
160R17	R1	1 <sup>1</sup> / <sub>8</sub> - 3 <sup>3</sup> / <sub>4</sub> "	11.90	10.885	17	4	1.156	3 <sup>5</sup> / <sub>32</sub> "	2 <sup>7</sup> / <sub>8</sub> "	1 <sup>23</sup> / <sub>32</sub> "	0	5 <sup>3</sup> / <sub>8</sub> "	28.0	
160R18	R1	1 <sup>1</sup> / <sub>8</sub> - 3 <sup>3</sup> / <sub>4</sub> "	12.54	11.518	18	4	1.156	3 <sup>5</sup> / <sub>32</sub> "	2 <sup>7</sup> / <sub>8</sub> "	1 <sup>23</sup> / <sub>32</sub> "	0	5 <sup>3</sup> / <sub>8</sub> "	31.9	
160R19	R1	1 <sup>1</sup> / <sub>8</sub> - 3 <sup>3</sup> / <sub>4</sub> "	13.19	12.151	19	4	1.156	3 <sup>5</sup> / <sub>32</sub> "	2 <sup>7</sup> / <sub>8</sub> "	1 <sup>23</sup> / <sub>32</sub> "	0	5 <sup>3</sup> / <sub>8</sub> "	35.9	
160R20	R2	1 <sup>3</sup> / <sub>8</sub> - 3 <sup>5</sup> / <sub>8</sub> "	13.83	12.785	20	6	1.156	5 <sup>5</sup> / <sub>32</sub> "	4 <sup>7</sup> / <sub>8</sub> "	1 <sup>23</sup> / <sub>32</sub> "	2	5 <sup>3</sup> / <sub>8</sub> "	51.0	
160R21	R2	1 <sup>3</sup> / <sub>8</sub> - 3 <sup>5</sup> / <sub>8</sub> "	14.47	13.419	21	6	1.156	5 <sup>5</sup> / <sub>32</sub> "	4 <sup>7</sup> / <sub>8</sub> "	1 <sup>23</sup> / <sub>32</sub> "	2	5 <sup>3</sup> / <sub>8</sub> "	56.0	
160R22	R2	1 <sup>3</sup> / <sub>8</sub> - 3 <sup>5</sup> / <sub>8</sub> "	15.11	14.053	22	6	1.156	5 <sup>5</sup> / <sub>32</sub> "	4 <sup>7</sup> / <sub>8</sub> "	1 <sup>23</sup> / <sub>32</sub> "	2	5 <sup>3</sup> / <sub>8</sub> "	60.0	
160R23	R2	1 <sup>3</sup> / <sub>8</sub> - 3 <sup>5</sup> / <sub>8</sub> "	15.75	14.688	23	6	1.156	5 <sup>5</sup> / <sub>32</sub> "	4 <sup>7</sup> / <sub>8</sub> "	1 <sup>23</sup> / <sub>32</sub> "	2	5 <sup>3</sup> / <sub>8</sub> "	65.0	
160R24	R2	1 <sup>3</sup> / <sub>8</sub> - 3 <sup>5</sup> / <sub>8</sub> "	16.39	15.323	24	6	1.156	5 <sup>5</sup> / <sub>32</sub> "	4 <sup>7</sup> / <sub>8</sub> "	1 <sup>23</sup> / <sub>32</sub> "	2	5 <sup>3</sup> / <sub>8</sub> "	71.5	
160R25	R2	1 <sup>3</sup> / <sub>8</sub> - 3 <sup>5</sup> / <sub>8</sub> "	17.03	15.958	25	6	1.156	5 <sup>5</sup> / <sub>32</sub> "	4 <sup>7</sup> / <sub>8</sub> "	1 <sup>23</sup> / <sub>32</sub> "	2	5 <sup>3</sup> / <sub>8</sub> "	74.0	
160R26	R2	1 <sup>3</sup> / <sub>8</sub> - 3 <sup>5</sup> / <sub>8</sub> "	17.67	16.593	26	6	1.156	5 <sup>5</sup> / <sub>32</sub> "	4 <sup>7</sup> / <sub>8</sub> "	1 <sup>23</sup> / <sub>32</sub> "	2	5 <sup>3</sup> / <sub>8</sub> "	79.0	
160R28	R2	1 <sup>3</sup> / <sub>8</sub> - 3 <sup>5</sup> / <sub>8</sub> "	18.95	17.863	28	6	1.156	5 <sup>5</sup> / <sub>32</sub> "	4 <sup>7</sup> / <sub>8</sub> "	1 <sup>23</sup> / <sub>32</sub> "	2	5 <sup>3</sup> / <sub>8</sub> "	99.8	
160R30	R2	1 <sup>3</sup> / <sub>8</sub> - 3 <sup>5</sup> / <sub>8</sub> "	20.23	19.134	30	6	1.156	5 <sup>5</sup> / <sub>32</sub> "	4 <sup>7</sup> / <sub>8</sub> "	1 <sup>23</sup> / <sub>32</sub> "	2	5 <sup>3</sup> / <sub>8</sub> "	106.0	
160S30	S2	1 <sup>7</sup> / <sub>8</sub> - 4 <sup>3</sup> / <sub>16</sub> "	20.23	19.134	30	6	1.156	7 <sup>1</sup> / <sub>8</sub> "	6 <sup>3</sup> / <sub>4</sub> "	2 <sup>23</sup> / <sub>32</sub> "	2 <sup>7</sup> / <sub>8</sub> "	6 <sup>3</sup> / <sub>8</sub> "	115.0	
160S35	S2	1 <sup>7</sup> / <sub>8</sub> - 4 <sup>3</sup> / <sub>16</sub> "	23.42	22.312	35	6	1.156	7 <sup>1</sup> / <sub>8</sub> "	6 <sup>3</sup> / <sub>4</sub> "	2 <sup>23</sup> / <sub>32</sub> "	2 <sup>7</sup> / <sub>8</sub> "	6 <sup>3</sup> / <sub>8</sub> "	150.0	
160S40	S2	1 <sup>7</sup> / <sub>8</sub> - 4 <sup>3</sup> / <sub>16</sub> "	26.61	25.419	40	6	1.156	7 <sup>1</sup> / <sub>8</sub> "	6 <sup>3</sup> / <sub>4</sub> "	2 <sup>23</sup> / <sub>32</sub> "	2 <sup>7</sup> / <sub>8</sub> "	6 <sup>3</sup> / <sub>8</sub> "	165.0	
160S45	S2	1 <sup>7</sup> / <sub>8</sub> - 4 <sup>3</sup> / <sub>16</sub> "	29.80	28.671	45	6	1.156	7 <sup>1</sup> / <sub>8</sub> "	6 <sup>3</sup> / <sub>4</sub> "	2 <sup>23</sup> / <sub>32</sub> "	2 <sup>7</sup> / <sub>8</sub> "	6 <sup>3</sup> / <sub>8</sub> "	204.0	
160S60	U0	2 <sup>3</sup> / <sub>8</sub> - 5 <sup>1</sup> / <sub>2</sub> "	39.36	38.215	60	6	1.156	5 <sup>25</sup> / <sub>32</sub> "	5 <sup>1</sup> / <sub>4</sub> "	1 <sup>21</sup> / <sub>32</sub> "	1 <sup>15</sup> / <sub>16</sub> "	8 <sup>3</sup> / <sub>8</sub> "	354.0	
160S70	U0	2 <sup>3</sup> / <sub>8</sub> - 5 <sup>1</sup> / <sub>2</sub> "	45.73	44.578	70	6	1.156	5 <sup>25</sup> / <sub>32</sub> "	5 <sup>1</sup> / <sub>4</sub> "	1 <sup>21</sup> / <sub>32</sub> "	1 <sup>15</sup> / <sub>16</sub> "	8 <sup>3</sup> / <sub>8</sub> "	308.0	
160S80	U1	2 <sup>3</sup> / <sub>8</sub> - 5 <sup>1</sup> / <sub>2</sub> "	52.10	50.943	80	6	1.156	7 <sup>19</sup> / <sub>32</sub> "	7 <sup>1</sup> / <sub>8</sub> "	2 <sup>19</sup> / <sub>32</sub> "	2 <sup>7</sup> / <sub>8</sub> "	8 <sup>3</sup> / <sub>8</sub> "	394.0	

Sprockets

# No.200 | Sprockets with Split Taper Bushings

- Pitch **2 1/2"**
- Roller  $\phi$  **1.562"**
- Tooth width B1 **1.389"**

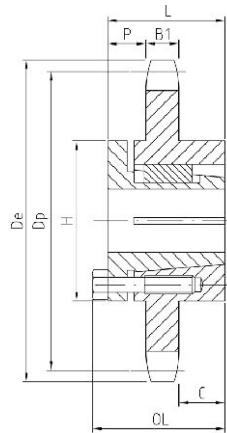

TYPE 6



## Single-Split Taper Bushed

Part Number	Bushing	Bore Range	De	Dp	Type	No. Teeth	B1	OL	L	P	C	H	Wt. Less Bushing
200R12	R2	1 3/8 - 3 5/8"	10.83"	9.660"	6	12	1.389"	5 5/32"	4 7/8"	1 1/2"	2	5 3/8"	35.3
200S13	S2	1 7/8 - 4 3/16	11.64	10.447	6	13	1.389	7 1/8	6 3/4	2 1/2	2 7/8	6 3/8	52.2
200S14	S2	1 7/8 - 4 3/16	12.46	11.235	6	14	1.389	7 1/8	6 3/4	2 1/2	2 7/8	6 3/8	57.5
200S15	S2	1 7/8 - 4 3/16	13.26	12.025	6	15	1.389	7 1/8	6 3/4	2 1/2	2 7/8	6 3/8	61.0
200S16	S2	1 7/8 - 4 3/16	14.07	12.815	6	16	1.389	7 1/8	6 3/4	2 1/2	2 7/8	6 3/8	71.0
200S17	S2	1 7/8 - 4 3/16	14.87	13.605	6	17	1.389	7 1/8	6 3/4	2 1/2	2 7/8	6 3/8	79.0
200U18	U0	2 3/8 - 5 1/2	15.68	14.397	6	18	1.389	5 23/32	5 1/4	2 17/32	1 5/8	8 3/8	76.5
200U19	U0	2 3/8 - 5 1/2	16.48	15.190	6	19	1.389	5 23/32	5 1/4	2 17/32	1 5/8	8 3/8	83.7
200U20	U0	2 3/8 - 5 1/2	17.26	15.982	6	20	1.389	5 23/32	5 1/4	2 17/32	1 5/8	8 3/8	91.3
200U21	U0	2 3/8 - 5 1/2	18.09	16.775	6	21	1.389	5 23/32	5 1/4	2 17/32	1 5/8	8 3/8	99.4
200U22	U0	2 3/8 - 5 1/2	18.89	17.567	6	22	1.389	5 23/32	5 1/4	2 17/32	1 5/8	8 3/8	110.0
200U23	U0	2 3/8 - 5 1/2	19.69	18.360	6	23	1.389	5 23/32	5 1/4	2 17/32	1 5/8	8 3/8	117.0
200U24	U0	2 3/8 - 5 1/2	20.49	19.152	6	24	1.389	5 23/32	5 1/4	2 17/32	1 5/8	8 3/8	126.0
200U25	U0	2 3/8 - 5 1/2	21.29	19.947	6	25	1.389	5 23/32	5 1/4	2 17/32	1 5/8	8 3/8	140.0
200U26	U0	2 3/8 - 5 1/2	22.09	20.740	6	26	1.389	5 23/32	5 1/4	2 17/32	1 5/8	8 3/8	150.0
200U28	U0	2 3/8 - 5 1/2	23.69	22.330	6	28	1.389	5 23/32	5 1/4	2 17/32	1 5/8	8 3/8	169.0
200U30	U0	2 3/8 - 5 1/2	25.29	23.917	6	30	1.389	5 23/32	5 1/4	2 17/32	1 5/8	8 3/8	188.0
200U32	U0	2 3/8 - 5 1/2	26.88	25.505	6	32	1.389	5 23/32	5 1/4	2 17/32	1 5/8	8 3/8	212.0
200U35	U1	2 3/8 - 5 1/2	29.28	27.890	6	35	1.389	7 19/32	7 1/8	2 7/8	2 7/8	8 3/8	252.0
200U40	U1	2 3/8 - 5 1/2	33.27	31.865	6	40	1.389	7 19/32	7 1/8	2 7/8	2 7/8	8 3/8	306.0
200U45	U1	2 3/8 - 5 1/2	37.25	35.840	6	45	1.389	7 19/32	7 1/8	2 7/8	2 7/8	8 3/8	290.0
200U54	U2	2 7/16 - 5 1/2	44.42	42.995	6	54	1.389	10 19/32	10 1/8	3 29/32	4 1/4	8 3/8	385.0
200U60	U2	2 7/16 - 5	49.20	47.767	6	60	1.389	10 19/32	10 1/8	3 29/32	4 1/4	8 3/8	445.0



**GOODWILL**

# No.35 | Sprockets with QD Bushings

- Pitch  $3/8"$
- Roller  $\phi$   $0.200"$
- Tooth width B1  $0.168"$

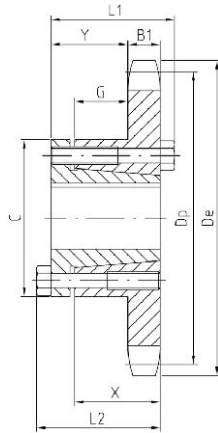

QD-TYPE B

## Single-Type "QD"

No. Teeth	Part Number	Bushing	De	Dp	Type	Max. Bore	L1	L2	C	Y	G	X	B1	Weight(Approx.)	
														With Hub	Rim Only
19	35JA19	JA	2.470	2.278	B	1 1/4	1 1/8	1 1/8	2 1/16	53/64	29/64	5/8	.168	1.18	.28
20	35JA20	JA	2.590	2.397	B	1 1/4	1 1/8	1 1/8	2 1/16	53/64	29/64	5/8	.168	1.22	.32
21	35JA21	JA	2.710	2.516	B	1 1/4	1 1/8	1 1/8	2 1/16	53/64	29/64	5/8	.168	1.24	.34
22	35JA22	JA	2.830	2.635	B	1 1/4	1 1/8	1 1/8	2 1/16	53/64	29/64	5/8	.168	1.26	.36
23	35JA23	JA	2.950	2.754	B	1 1/4	1 1/8	1 1/8	2 1/16	53/64	29/64	5/8	.168	1.28	.38
24	35JA24	JA	3.070	3.873	B	1 1/4	1 1/8	1 1/8	2 1/16	53/64	29/64	5/8	.168	1.30	.40
25	35JA25	JA	3.190	2.992	B	1 1/4	1 1/8	1 1/8	2 1/16	53/64	29/64	5/8	.168	1.34	.44
26	35JA26	JA	3.310	3.111	B	1 1/4	1 1/8	1 1/8	2 1/16	53/64	29/64	5/8	.168	1.36	.46
27	35JA27	JA	3.430	3.230	B	1 1/4	1 1/8	1 1/8	2 1/16	53/64	29/64	5/8	.168	1.38	.48
28	35JA28	JA	3.550	3.349	B	1 1/4	1 1/8	1 1/8	2 1/16	53/64	29/64	5/8	.168	1.42	.52
30	35JA30	JA	3.790	3.588	B	1 1/4	1 1/8	1 1/8	2 1/16	53/64	29/64	5/8	.168	1.46	.56
32	35JA32	JA	4.030	3.862	B	1 1/4	1 1/8	1 1/8	2 1/16	53/64	29/64	5/8	.168	1.68	.78
35	35JA35	JA	4.390	4.183	B	1 1/4	1 1/8	1 1/8	2 1/16	53/64	29/64	5/8	.168	1.94	1.04
36	35SH36	SH	4.510	4.303	B	1 5/8	1 7/16	1 7/16	2 11/16	1 5/8	4 1/64	1 3/16	.168	2.06	1.06
40	35SH40	SH	4.990	4.780	B	1 5/8	1 7/16	1 7/16	2 11/16	1 5/8	4 1/64	1 3/16	.168	2.18	1.18
42	35SH42	SH	5.230	5.018	B	1 5/8	1 7/16	1 7/16	2 11/16	1 5/8	4 1/64	1 3/16	.168	2.26	1.26
45	35SH45	SH	5.590	5.376	B	1 5/8	1 7/16	1 7/16	2 11/16	1 5/8	4 1/64	1 3/16	.168	2.40	1.40
48	35SH48	SH	5.950	5.734	B	1 5/8	1 7/16	1 7/16	2 11/16	1 5/8	4 1/64	1 3/16	.168	2.58	1.58
54	35SH54	SH	6.660	6.449	B	1 5/8	1 7/16	1 7/16	2 11/16	1 5/8	4 1/64	1 3/16	.168	2.88	1.88
60	35SH60	SH	7.380	7.165	B	1 5/8	1 7/16	1 7/16	2 11/16	1 5/8	4 1/64	1 3/16	.168	3.28	2.28
70	35SH70	SH	8.580	8.358	B	1 5/8	1 7/16	1 7/16	2 11/16	1 5/8	4 1/64	1 3/16	.168	3.94	2.94
72	35SH72	SH	8.810	8.597	B	1 5/8	1 7/16	1 7/16	2 11/16	1 5/8	4 1/64	1 3/16	.168	4.14	3.14
80	35SH80	SH	9.770	9.552	B	1 5/8	1 7/16	1 7/16	2 11/16	1 5/8	4 1/64	1 3/16	.168	4.68	3.68
84	35SH84	SH	10.250	10.029	B	1 5/8	1 7/16	1 7/16	2 11/16	1 5/8	4 1/64	1 3/16	.168	4.86	3.96
96	35SH96	SH	11.680	11.461	B	1 5/8	1 7/16	1 7/16	2 11/16	1 5/8	4 1/64	1 3/16	.168	6.38	5.38
112	35SH112	SH	13.590	13.371	B	1 5/8	1 7/16	1 7/16	2 11/16	1 5/8	4 1/64	1 3/16	.168	7.60	6.60

Sprockets

# No.35-2

# No.35-3 | Sprockets with QD Bushings



- Pitch  $\frac{3}{8}$ "
- Roller  $\phi$  0.200"
- Tooth width b1 0.162"
- Tooth width B2 0.561"
- Tooth width B3 0.960"

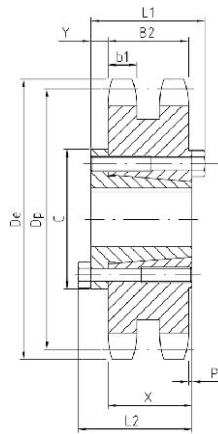

QD-TYPE C

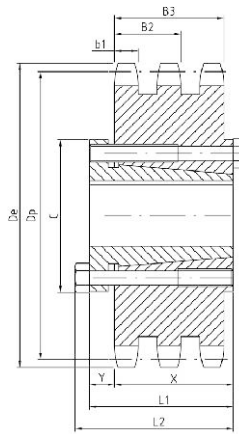

QD-TYPE C

## Double-Type "QD"

No. Teeth	Part Number	Bushing	De	Dp	Type	Max. Bore	L1	L2	C	Y	P	X	B1	B2	Weight(Approx.)	
															With Hub	Rim Only
68	D35SDS68	SDS	8.340	8.120	C	2	1 1/2	1 1/2	3 7/16	9/16	3/16	3/4	.162	.561	8.40	7.40
72	D35SDS72	SDS	8.810	8.597	C	2	1 1/2	1 1/2	3 7/16	9/16	3/16	3/4	.162	.561	9.28	8.28
76	D35SDS76	SDS	9.290	9.074	C	2	1 1/2	1 1/2	3 7/16	9/16	3/16	3/4	.162	.561	10.32	9.32
84	D35SK84	SK	10.250	10.029	C	2 5/8	2 1/8	2 1/8	3 7/8	5/8	1 1/16	1 1/4	.162	.561	13.94	11.94
95	D35SK95	SK	11.560	11.342	C	2 5/8	2 1/8	2 1/8	3 7/8	5/8	1 1/16	1 1/4	.162	.561	17.22	15.22
96	D35SK96	SK	11.680	11.461	C	2 5/8	2 1/8	2 1/8	3 7/8	5/8	1 1/16	1 1/4	.162	.561	17.74	15.74
102	D35SK102	SK	12.400	12.177	C	2 5/8	2 1/8	2 1/8	3 7/8	5/8	1 1/16	1 1/4	.162	.561	19.76	17.76

## Triple-Type "QD"

No. Teeth	Part Number	Bushing	De	Dp	Type	Max. Bore	L1	L2	C	Y	P	X	b1	B3	Weight(Approx.)	
															With Hub	Rim Only
68	E35SK68	SK	8.340	8.120	C	2 5/8	2 1/8	2 1/8	3 7/8	5/8	1 9/64	1 1/4	.162	.960	13.90	11.90
72	E35SK72	SK	8.810	8.597	C	2 5/8	2 1/8	2 1/8	3 7/8	5/8	1 9/64	1 1/4	.162	.960	15.56	13.56
76	E35SK76	SK	9.290	9.074	C	2 5/8	2 1/8	2 1/8	3 7/8	5/8	1 9/64	1 1/4	.162	.960	17.42	15.42
84	E35SK84	SK	10.250	10.029	C	2 5/8	2 1/8	2 1/8	3 7/8	5/8	1 9/64	1 1/4	.162	.960	20.92	18.92
95	E35SK95	SK	11.560	11.342	C	2 5/8	2 1/8	2 1/8	3 7/8	5/8	1 9/64	1 1/4	.162	.960	26.76	24.76
96	E35SK96	SK	11.680	11.461	C	2 5/8	2 1/8	2 1/8	3 7/8	5/8	1 9/64	1 1/4	.162	.960	27.58	25.58
102	E35SK102	SK	12.400	12.177	C	2 5/8	2 1/8	2 1/8	3 7/8	5/8	1 9/64	1 1/4	.162	.960	31.18	29.18

Sprockets

# No.41 | Sprockets with QD Bushings

- Pitch                    2"
- Roller  $\phi$                     0.306"
- Tooth width B1 0.227"

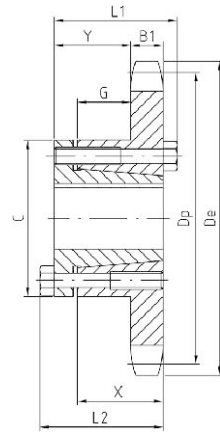

QD-TYPE B



## Single-Type "QD"

No. Teeth	Part Number	Bushing	De	Dp	Type	Max. Bore	L1	L2	C	Y	G	X	B1	Weight(Approx.)	
														With Hub	Rim Only
15	41JA15	JA	2.650	2.405	B	1 <sup>1</sup> / <sub>4</sub>	1 <sup>1</sup> / <sub>8</sub>	1 <sup>1</sup> / <sub>8</sub>	2 <sup>1</sup> / <sub>16</sub>	49 <sup>1</sup> / <sub>64</sub>	25 <sup>1</sup> / <sub>64</sub>	5 <sup>1</sup> / <sub>8</sub>	.227	1.22	.32
16	41JA16	JA	2.810	2.563	B									1.30	.40
17	41JA17	JA	2.980	2.721	B									1.40	.50
18	41JA18	JA	3.140	2.879	B									1.50	.60
19	41JA19	JA	3.300	3.038	B	1 <sup>1</sup> / <sub>4</sub>	1 <sup>1</sup> / <sub>8</sub>	1 <sup>1</sup> / <sub>8</sub>	2 <sup>1</sup> / <sub>16</sub>	49 <sup>1</sup> / <sub>64</sub>	25 <sup>1</sup> / <sub>64</sub>	5 <sup>1</sup> / <sub>8</sub>	.227	1.58	.68
20	41SH20	SH	3.460	3.196	B	1 <sup>5</sup> / <sub>8</sub>	1 <sup>7</sup> / <sub>16</sub>	1 <sup>7</sup> / <sub>16</sub>	2 <sup>1</sup> / <sub>16</sub>	1 <sup>1</sup> / <sub>32</sub>	37 <sup>1</sup> / <sub>64</sub>	13 <sup>1</sup> / <sub>16</sub>	.227	1.78	.78
21	41SH21	SH	3.620	3.355	B									1.82	.82
22	41SH22	SH	3.780	3.513	B									2.06	1.06
23	41SH23	SH	3.940	3.672	B									2.14	1.14
24	41SH24	SH	4.100	3.831	B									2.16	1.16
25	41SH25	SH	4.260	3.989	B									2.22	1.22
26	41SH26	SH	4.420	4.148	B									2.26	1.26
27	41SH27	SH	4.580	4.307	B									2.40	1.40
28	41SH28	SH	4.740	4.466	B									2.54	1.54
30	41SH30	SH	5.060	4.783	B									2.58	1.58
32	41SH32	SH	5.380	5.101	B									2.68	1.68
35	41SH35	SH	5.860	5.578	B	1 <sup>5</sup> / <sub>8</sub>	1 <sup>7</sup> / <sub>16</sub>	1 <sup>7</sup> / <sub>16</sub>	2 <sup>1</sup> / <sub>16</sub>	1 <sup>1</sup> / <sub>32</sub>	37 <sup>1</sup> / <sub>64</sub>	13 <sup>1</sup> / <sub>16</sub>	.227	3.46	2.47
36	41SDS36	SDS	6.020	5.737	B	2	1 <sup>1</sup> / <sub>2</sub>	1 <sup>1</sup> / <sub>2</sub>	3 <sup>3</sup> / <sub>16</sub>	1 <sup>3</sup> / <sub>32</sub>	17 <sup>1</sup> / <sub>32</sub>	3 <sup>1</sup> / <sub>4</sub>	.227	2.92	1.92
40	41SDS40	SDS	6.650	6.373	B									3.32	2.32
42	41SDS42	SDS	6.970	6.691	B									3.44	2.44
45	41SDS45	SDS	7.450	7.168	B									3.76	2.76
48	41SDS48	SDS	7.930	7.645	B									4.36	3.36
54	41SDS54	SDS	8.890	8.599	B									4.98	3.98
60	41SDS60	SDS	9.840	9.554	B	2	1 <sup>1</sup> / <sub>2</sub>	1 <sup>1</sup> / <sub>2</sub>	3 <sup>3</sup> / <sub>16</sub>	1 <sup>3</sup> / <sub>32</sub>	17 <sup>1</sup> / <sub>32</sub>	3 <sup>1</sup> / <sub>4</sub>	.227	6.54	5.54
70	41SK70	SK	11.430	11.145	B	2 <sup>7</sup> / <sub>8</sub>	2 <sup>7</sup> / <sub>8</sub>	2 <sup>7</sup> / <sub>8</sub>	3 <sup>7</sup> / <sub>8</sub>	14 <sup>1</sup> / <sub>64</sub>	1 <sup>1</sup> / <sub>32</sub>	1 <sup>1</sup> / <sub>4</sub>	.227	9.42	7.42
72	41SK72	SK	11.750	11.463	B									10.02	8.02
80	41SK80	SK	13.030	12.736	B									11.64	9.64
84	41SK84	SK	13.660	13.372	B									12.40	10.40
96	41SK96	SK	15.570	15.281	B									14.82	12.82
112	41SK112	SK	18.120	17.828	B	2 <sup>7</sup> / <sub>8</sub>	2 <sup>7</sup> / <sub>8</sub>	2 <sup>7</sup> / <sub>8</sub>	3 <sup>7</sup> / <sub>8</sub>	14 <sup>1</sup> / <sub>64</sub>	1 <sup>1</sup> / <sub>32</sub>	1 <sup>1</sup> / <sub>4</sub>	.227	19.28	17.28

# No.40 | Sprockets with QD Bushings |

- Pitch                    2"     Roller  $\phi$                     0.312"
- Tooth width B1 0.284"

## Single-Type "QD" With Hardened Teeth

No. Teeth	Part Number
15	40JA15H
16	40JA16H
17	40JA17H
18	40JA18H
19	40JA19H
20	40SH20H
21	40SH21H
22	40SH22H
23	40SH23H
24	40SH24H
25	40SH25H
26	40SH26H
27	40SH27H
28	40SH28H
30	40SH30H

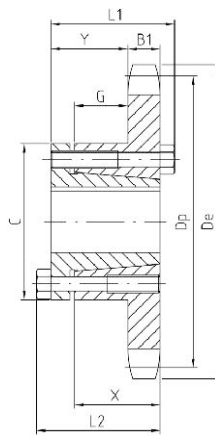

QD-TYPE B

## Single-Type "QD"

No. Teeth	Part Number	Bushing	De	Dp	Type	Max. Bore	L1	L2	C	Y	G	X	B1	Weight(Approx.)	
														With Hub	Rim Only
15	40JA15	JA	2.650	2.405	B	1 <sup>1</sup> / <sub>4</sub>	1 <sup>1</sup> / <sub>8</sub>	1 <sup>1</sup> / <sub>8</sub>	2 <sup>1</sup> / <sub>16</sub>	2 <sup>3</sup> / <sub>32</sub>	1 <sup>1</sup> / <sub>32</sub>	5 <sup>5</sup> / <sub>8</sub>	.284	1.24	.34
16	40JA16	JA	2.810	2.563	B									1.30	.40
17	40JA17	JA	2.980	2.721	B									1.38	.48
18	40JA18	JA	3.140	2.879	B									1.44	.54
19	40JA19	JA	3.300	3.038	B	1 <sup>1</sup> / <sub>4</sub>	1 <sup>1</sup> / <sub>8</sub>	1 <sup>1</sup> / <sub>8</sub>	2 <sup>1</sup> / <sub>16</sub>	2 <sup>3</sup> / <sub>32</sub>	1 <sup>1</sup> / <sub>32</sub>	5 <sup>5</sup> / <sub>8</sub>	.284	1.50	.60
20	40SH20	SH	3.460	3.196	B	1 <sup>7</sup> / <sub>8</sub>	1 <sup>7</sup> / <sub>16</sub>	1 <sup>7</sup> / <sub>16</sub>	2 <sup>1</sup> / <sub>16</sub>	3 <sup>1</sup> / <sub>32</sub>	1 <sup>7</sup> / <sub>32</sub>	1 <sup>3</sup> / <sub>16</sub>	.284	1.76	.76
21	40SH21	SH	3.620	3.355	B									1.84	.84
22	40SH22	SH	3.780	3.513	B									1.92	.92
23	40SH23	SH	3.940	3.672	B									2.14	1.14
24	40SH24	SH	4.100	3.831	B									2.22	1.22
25	40SH25	SH	4.260	3.989	B									2.30	1.30
26	40SH26	SH	4.420	4.148	B									2.44	1.44
27	40SH27	SH	4.580	4.307	B									2.46	1.46
28	40SH28	SH	4.740	4.466	B									2.54	1.54
30	40SH30	SH	5.060	4.783	B									2.72	1.72
32	40SH32	SH	5.380	5.101	B									2.90	1.90
35	40SH35	SH	5.860	5.578	B	1 <sup>5</sup> / <sub>8</sub>	1 <sup>7</sup> / <sub>16</sub>	1 <sup>7</sup> / <sub>16</sub>	3	3 <sup>1</sup> / <sub>32</sub>	1 <sup>7</sup> / <sub>32</sub>	1 <sup>3</sup> / <sub>16</sub>	.284	3.22	2.22
36	40SDS36	SDS	6.020	5.737	B	2	1 <sup>1</sup> / <sub>2</sub>	1 <sup>1</sup> / <sub>2</sub>	3 <sup>3</sup> / <sub>16</sub>	1 <sup>1</sup> / <sub>32</sub>	1 <sup>5</sup> / <sub>32</sub>	3 <sup>3</sup> / <sub>4</sub>	.284	3.20	2.20
40	40SDS40	SDS	6.650	6.373	B									3.72	2.72
42	40SDS42	SDS	6.970	6.691	B									3.92	2.92
45	40SDS45	SDS	7.450	7.168	B									4.32	3.32
48	40SDS48	SDS	7.930	7.645	B									4.70	3.70
54	40SDS54	SDS	8.890	8.599	B									5.78	4.78
60	40SDS60	SDS	9.840	9.554	B	2	1 <sup>1</sup> / <sub>2</sub>	1 <sup>1</sup> / <sub>2</sub>	3 <sup>3</sup> / <sub>16</sub>	1 <sup>1</sup> / <sub>32</sub>	1 <sup>5</sup> / <sub>32</sub>	3 <sup>3</sup> / <sub>4</sub>	.284	6.86	5.86
70	40SK70	SK	11.430	11.145	B	2 <sup>5</sup> / <sub>8</sub>	2 <sup>1</sup> / <sub>8</sub>	2 <sup>1</sup> / <sub>8</sub>	3 <sup>7</sup> / <sub>8</sub>	1 <sup>1</sup> / <sub>32</sub>	3 <sup>1</sup> / <sub>32</sub>	1 <sup>1</sup> / <sub>4</sub>	.284	10.68	8.68
72	40SK72	SK	11.750	11.463	B									10.84	8.84
80	40SK80	SK	13.030	12.736	B									13.20	11.20
84	40SK84	SK	13.660	13.372	B									13.56	11.56
96	40SK96	SK	15.570	15.281	B									17.76	15.76
112	40SK112	SK	18.120	17.828	B	2 <sup>5</sup> / <sub>8</sub>	2 <sup>1</sup> / <sub>8</sub>	2 <sup>1</sup> / <sub>8</sub>	3 <sup>7</sup> / <sub>8</sub>	1 <sup>1</sup> / <sub>32</sub>	3 <sup>1</sup> / <sub>32</sub>	1 <sup>1</sup> / <sub>4</sub>	.284	22.28	20.28

# No.40-2

# No.40-3 | Sprockets with QD Bushings



- Pitch  $1\frac{1}{2}''$
- Roller  $\phi$  0.312''
- Tooth width b1 0.275''
- Tooth width B2 0.841''
- Tooth width B3 1.407''

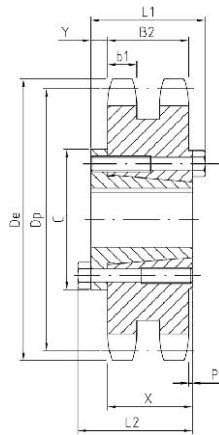

QD-TYPE C

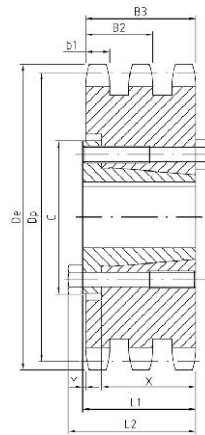

QD-TYPE B

## Double-Type "QD"

No. Teeth	Part Number	Bushing	De	Dp	Type	Max. Bore	L1	L2	C	Y	P	X	b1	B2	Weight(Approx.)	
															With Hub	Rim Only
36	D40SK36	SK	6.020	5.737	C	2 5/8	2 1/8	2 1/8	3 7/8	5/8	13/32	1 1/4	.275	.841	6.68	4.68
40	D40SK40	SK	6.650	6.373	C										8.02	6.02
42	D40SK42	SK	6.970	6.691	C										8.82	6.82
45	D40SK45	SK	7.450	7.168	C										9.98	7.98
48	D40SK48	SK	7.930	7.645	C										11.22	9.22
52	D40SK52	SK	8.570	8.281	C										13.04	11.04
54	D40SK54	SK	8.890	8.599	C										14.06	12.06
60	D40SK60	SK	9.840	9.554	C	2 5/8	2 1/8	2 1/8	3 7/8	5/8	13/32	1 1/4	.275	.841	16.98	14.98
68	D40SF68	SF	11.120	10.826	C	2 15/16	2 1/4	2 1/4	4 5/8	3/4	13/32	1 1/4	.275	.841	22.72	19.72
72	D40SF72	SF	11.750	11.463	C										24.20	22.20
76	D40SF76	SF	12.390	12.099	C										28.20	25.20
84	D40SF84	SF	13.660	13.372	C										33.64	30.64
95	D40SF95	SF	15.410	15.122	C										40.22	37.22
102	D40SF102	SF	16.530	16.236	C										42.70	39.70
112	D40SF112	SF	18.120	17.828	C	2 15/16	2 1/4	2 1/4	4 5/8	3/4	13/32	1 1/4	.275	.841	52.60	49.60

## Triple-Type "QD"

No. Teeth	Part Number	Bushing	De	Dp	Type	Max. Bore	L1	L2	C	Y	X	b1	B3	Weight(Approx.)	
														With Hub	Rim Only
36	E40SK36	SK	6.020	5.737	B	2 5/8	2 1/8	2 1/8	3 7/8	15/32	1 1/4	.275	1.407	8.16	6.16
42	E40SK42	SK	6.970	6.691	B									11.92	9.52
48	E40SK48	SK	7.930	7.645	B									15.13	13.16
52	E40SK52	SK	8.570	8.281	B									18.08	16.08
60	E40SK60	SK	9.840	9.554	B	2 5/8	2 1/8	2 1/8	3 7/8	15/32	1 1/4	.275	1.407	24.60	22.60
68	E40SF68	SF	11.120	10.826	B	2 15/16	2 1/4	2 1/4	4 5/8	19/32	1 1/4	.275	1.407	31.98	29.98
72	E40SF72	SF	11.750	11.463	B									37.40	34.40
76	E40SF76	SF	12.390	12.099	B									51.92	48.92
84	E40SF84	SF	13.660	13.372	B									56.70	53.78
95	E40SF95	SF	15.410	15.122	B									58.94	55.94
102	E40SF102	SF	16.530	16.236	B	2 15/16	2 1/4	2 1/4	4 5/8	19/32	1 1/4	.275	1.407	62.24	59.24

Sprockets

# No.50 | Sprockets with QD Bushings |

- Pitch **5/8"**  Roller  $\phi$  **0.400"**
- Tooth width B1 **0.343"**

## Single-Type "QD" With Hardened Teeth

No. Teeth	Part Number
12	50JA12H
13	50JA13H
14	50JA14H
15	50JA15H
16	50JA16H
17	50SH17H
18	50SH18H
19	50SH19H
20	50SDS20H
21	50SDS21H
22	50SDS22H
23	50SDS23H
24	50SDS24H
25	50SDS25H
26	50SDS26H
27	50SDS27H
28	50SDS28H
30	50SDS30H

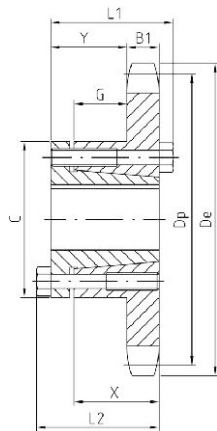

QD-TYPE B

## Single-Type "QD"

No. Teeth	Part Number	Bushing	De	Dp	Type	Max. Bore	L1	L2	C	Y	G	X	B1	Weight(Approx.)	
														With Hub	Rim Only
12	50JA12	JA	2.710	2.415	B	1/4	1/8	1/8	2 1/16	2 1/32	9/32	5/8	.343	1.24	.34
13	50JA13	JA	2.910	2.612	B									1.30	.40
14	50JA14	JA	3.110	2.803	B									1.45	.52
15	50JA15	JA	3.320	3.006	B									1.50	.60
16	50JA16	JA	3.520	3.204	B	1/4	1/8	1/8	2 1/16	2 1/32	9/32	5/8	.343	1.58	.68
17	50SH17	SH	3.720	3.401	B	1 7/8	1 7/16	1 7/16	2 1 1/16	2 29/32	15/32	1 13/16	.343	1.84	.84
18	50SH18	SH	3.920	3.599	B	1 9/8	1 7/16	1 7/16	2 1 1/16	2 29/32	15/32	1 13/16	.343	2.04	1.04
19	50SH19	SH	4.120	3.797	B	1 9/8	1 7/16	1 7/16	2 1 1/16	2 29/32	15/32	1 13/16	.343	2.24	1.24
20	50SDS20	SDS	4.320	3.995	B	2	1 1/2	1 1/2	3 3/16	3 1/32	1 13/32	3/4	.343	2.20	1.20
21	50SDS21	SDS	4.520	4.194	B									2.32	1.32
22	50SDS22	SDS	4.720	4.392	B									2.48	1.42
23	50SDS23	SDS	4.920	4.590	B									2.58	1.58
24	50SDS24	SDS	5.120	4.788	B									2.70	1.70
25	50SDS25	SDS	5.320	4.987	B									2.86	1.86
26	50SDS26	SDS	5.520	5.185	B									3.00	2.00
27	50SDS27	SDS	5.720	5.384	B									3.12	2.12
28	50SDS28	SDS	5.920	5.582	B									3.32	2.32
30	50SDS30	SDS	6.320	5.979	B									3.64	2.64
32	50SDS32	SDS	6.720	6.376	B									3.98	2.98
35	50SDS35	SDS	7.320	6.972	B									4.62	3.62
36	50SDS36	SDS	7.520	7.171	B									4.64	3.64
40	50SDS40	SDS	8.320	7.966	B									5.74	4.74
42	50SDS42	SDS	8.720	8.363	B									6.40	5.40
45	50SDS45	SDS	9.310	8.960	B									6.90	5.90
48	50SDS48	SDS	9.910	9.556	B	2	1 1/2	1 1/2	3 7/16	3 1/32	1 13/32	3/4	.343	7.66	6.66
54	50SK54	S K	11.110	10.749	B	2 5/8	2 7/8	2 7/8	3 7/8	1 17/32	2 29/32	1 1/4	.343	11.68	9.68
60	50SK60	S K	12.300	11.942	B									13.88	11.88
70	50SK70	S K	14.290	13.931	B									17.52	15.52
72	50SK72	S K	14.690	14.329	B	2 5/8	2 7/8	2 7/8	3 7/8	1 17/32	2 29/32	1 1/4	.343	18.44	16.44
80	50SF80	SF	16.280	15.920	B	2 5/16	2 1/4	2 1/4	4 7/8	1 21/32	2 29/32	1 1/4	.343	22.90	19.90
84	50SF84	SF	17.080	16.715	B									25.98	22.98
96	50SF96	SF	19.470	19.102	B									32.88	29.88
112	50SF112	SF	22.650	22.285	B	2 5/16	2 1/4	2 1/4	4 5/8	1 21/32	2 29/32	1 1/4	.343	43.10	40.10

# No.50-2

# No.50-3 | Sprockets with QD Bushings



- Pitch **5/8"**  Roller  $\phi$  **0.400"**
- Tooth width b1 **0.332"**  Tooth width B2 **1.045"**  Tooth width B3 **1.758"**

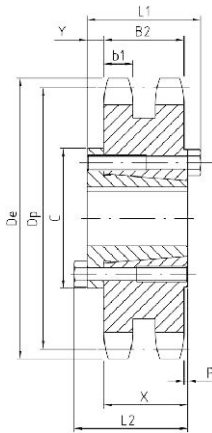

QD-TYPE C

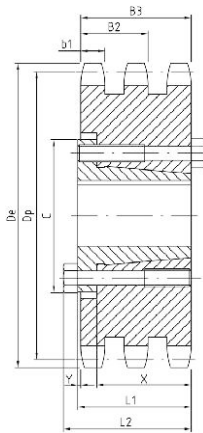

QD-TYPE B

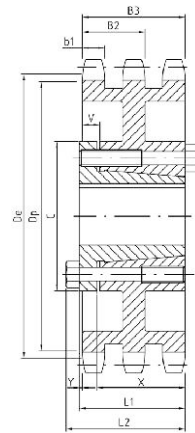

QD-TYPE B1

## Double-Type "QD"

No. Teeth	Part Number	Bushing	De	Dp	Type	Max. Bore	L1	L2	C	Y	P	X	b1	B2	Weight(Approx.)	
															With Hub	Rim Only
36	D50SK36	S K	7.520	7.171	C	2 <sup>5</sup> / <sub>8</sub>	2 <sup>1</sup> / <sub>8</sub>	2 <sup>1</sup> / <sub>8</sub>	3 <sup>7</sup> / <sub>8</sub>	5 <sup>5</sup> / <sub>8</sub>	1 <sup>3</sup> / <sub>64</sub>	1 <sup>1</sup> / <sub>4</sub>	.332	1.045	11.08	9.08
42	D50SK42	S K	8.720	8.363	C	2 <sup>5</sup> / <sub>8</sub>	2 <sup>1</sup> / <sub>8</sub>	2 <sup>1</sup> / <sub>8</sub>	3 <sup>7</sup> / <sub>8</sub>	5 <sup>5</sup> / <sub>8</sub>	1 <sup>3</sup> / <sub>64</sub>	1 <sup>1</sup> / <sub>4</sub>	.332	1.045	15.16	13.16
48	D50SK48	S K	9.910	9.556	C	2 <sup>5</sup> / <sub>8</sub>	2 <sup>1</sup> / <sub>8</sub>	2 <sup>1</sup> / <sub>8</sub>	3 <sup>7</sup> / <sub>8</sub>	5 <sup>5</sup> / <sub>8</sub>	1 <sup>3</sup> / <sub>64</sub>	1 <sup>1</sup> / <sub>4</sub>	.332	1.045	19.90	17.90
52	D50SF52	SF	10.710	10.351	C	2 <sup>15</sup> / <sub>16</sub>	2 <sup>1</sup> / <sub>4</sub>	2 <sup>1</sup> / <sub>4</sub>	4 <sup>5</sup> / <sub>8</sub>	3 <sup>3</sup> / <sub>4</sub>	1 <sup>3</sup> / <sub>64</sub>	1 <sup>1</sup> / <sub>4</sub>	.332	1.045	24.26	21.26
54	D50SF54	SF	11.110	10.749	C										26.18	23.18
60	D50SF60	SF	12.300	11.942	C										32.12	29.12
68	D50SF68	SF	13.890	13.533	C										41.16	38.16
72	D50SF72	SF	14.690	14.329	C										46.28	43.26
76	D50SF76	SF	15.490	15.124	C										47.00	44.00
84	D50SF84	SF	17.080	16.715	C										48.89	45.88
95	D50SF95	SF	19.270	18.903	C										61.80	58.88
102	D50SF102	SF	20.660	20.295	C										69.02	66.02
112	D50SF112	SF	22.650	22.285	C	2 <sup>15</sup> / <sub>16</sub>	2 <sup>1</sup> / <sub>4</sub>	2 <sup>1</sup> / <sub>4</sub>	4 <sup>5</sup> / <sub>8</sub>	3 <sup>3</sup> / <sub>4</sub>	1 <sup>3</sup> / <sub>64</sub>	1 <sup>1</sup> / <sub>4</sub>	.332	1.045	88.26	85.26

## Triple-Type "QD"

No. Teeth	Part Number	Bushing	De	Dp	Type	Max. Bore	L1	L2	C	Y	V	X	B1	B3	Weight(Approx.)	
															With Hub	Rim Only
36	E50SK36	S K	7.520	7.171	B	2 <sup>5</sup> / <sub>8</sub>	2 <sup>1</sup> / <sub>8</sub>	2 <sup>1</sup> / <sub>8</sub>	3 <sup>7</sup> / <sub>8</sub>	1 <sup>1</sup> / <sub>8</sub>		1 <sup>1</sup> / <sub>4</sub>	.332	1.758	14.8	12.8
42	E50SK42	S K	8.720	8.363	B	2 <sup>5</sup> / <sub>8</sub>	2 <sup>1</sup> / <sub>8</sub>	2 <sup>1</sup> / <sub>8</sub>	3 <sup>7</sup> / <sub>8</sub>	1 <sup>1</sup> / <sub>8</sub>		1 <sup>1</sup> / <sub>4</sub>	.332	1.758	21.5	19.5
48	E50SK48	S K	9.910	9.556	B	2 <sup>5</sup> / <sub>8</sub>	2 <sup>1</sup> / <sub>8</sub>	2 <sup>1</sup> / <sub>8</sub>	3 <sup>7</sup> / <sub>8</sub>	1 <sup>1</sup> / <sub>8</sub>		1 <sup>1</sup> / <sub>4</sub>	.332	1.758	29.6	27.6
52	E50SF52	SF	10.710	10.351	B	2 <sup>15</sup> / <sub>16</sub>	2 <sup>1</sup> / <sub>4</sub>	2 <sup>1</sup> / <sub>4</sub>	4 <sup>5</sup> / <sub>8</sub>	1 <sup>1</sup> / <sub>4</sub>		1 <sup>1</sup> / <sub>4</sub>	.332	1.758	31.6	28.6
60	E50SF60	SF	12.300	11.942	B										42.1	39.1
68	E50SF68	SF	13.890	13.533	B										53.8	50.8
72	E50SF72	SF	14.690	14.329	B1										46.6	43.6
76	E50SF76	SF	15.490	15.124	B1						1/2				49.9	46.9
84	E50SF84	SF	17.080	16.715	B1										53.9	50.9
95	E50SF95	SF	19.270	18.903	B1										62.3	59.3
102	E50SF102	SF	20.660	20.295	B1	2 <sup>15</sup> / <sub>16</sub>	2 <sup>1</sup> / <sub>4</sub>	2 <sup>1</sup> / <sub>4</sub>	4 <sup>5</sup> / <sub>8</sub>	1 <sup>1</sup> / <sub>4</sub>	1/2	1 <sup>1</sup> / <sub>4</sub>	.332	1.758	69.3	66.3

NOTE: Triple 50 stock sprockets with 25 teeth or less have hardened teeth.



**GOODWILL**

# No.60 | Sprockets with QD Bushings |

- Pitch  $3/4"$
- Roller  $\phi$   $0.468"$
- Tooth width B1  $0.459"$

## Single-Type "QD" With Hardened Teeth

No. Teeth	Part Number
11	60JA11H
12	60JA12H
13	60JA13H
14	60SH14H
15	60SH15H
16	60SH16H
17	60SDS17H
18	60SDS18H
19	60SDS19H
20	60SDS20H
21	60SDS21H
22	60SDS22H
23	60SDS23H
24	60SDS24H
25	60SDS25H
26	60SK26H
27	60SK27H
28	60SK28H
30	60SK30H

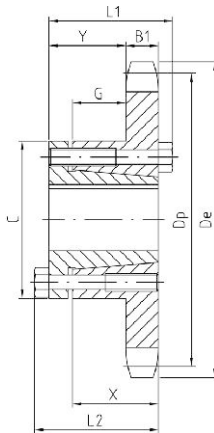

QD-TYPE B



## Single-Type "QD"

No. Teeth	Part Number	Bushing	De	Dp	Type	Max. Bore	L1	L2	C	Y	G	X	B1	Weight(Approx.)	
														With Hub	Rim Only
11	60JA11	JA	3.000	2.662	B	1 1/4	1 7/8	1 1/8	2 1/16	35/64	11/64	5/8	.459	1.36	.46
12	60JA12	JA	3.250	2.898	B	1 1/4	1 7/8	1 1/8	2 1/16	35/64	11/64	5/8	.459	1.50	.60
13	60JA13	JA	3.490	3.134	B	1 1/4	1 7/8	1 1/8	2 1/16	35/64	11/64	5/8	.459	1.66	.76
14	60SH14	SH	3.740	3.371	B	1 5/8	1 7/16	1 7/16	2 11/16	51/64	23/64	13/16	.459	1.88	.88
15	60SH15	SH	3.980	3.607	B	1 5/8	1 7/16	1 7/16	2 11/16	51/64	23/64	13/16	.459	2.08	1.08
16	60SH16	SH	4.220	3.844	B	1 5/8	1 7/16	1 7/16	2 11/16	51/64	23/64	13/16	.459	2.26	1.26
17	60SDS17	SDS	4.460	4.082	B	2	1 1/2	1 1/2	3 3/16	55/64	19/64	3/4	.459	2.38	1.38
18	60SDS18	SDS	4.700	4.319	B									2.56	1.56
19	60SDS19	SDS	4.950	4.557	B									2.76	1.76
20	60SDS20	SDS	5.190	4.794	B									3.00	2.00
21	60SDS21	SDS	5.430	5.032	B									3.20	2.20
22	60SDS22	SDS	5.670	5.270	B									3.44	2.44
23	60SDS23	SDS	5.910	5.508	B									3.70	2.70
24	60SDS24	SDS	6.150	5.746	B									3.94	2.94
25	60SDS25	SDS	6.390	5.984	B	2	1 1/2	1 1/2	3 3/16	55/64	19/64	3/4	.459	4.24	3.24
26	60SK26	SK	6.630	6.222	B	2 5/8	2 7/8	2 1/8	3 7/8	1 27/64	51/64	1 1/4	.459	6.18	4.18
27	60SK27	SK	6.870	6.460	B									6.52	4.52
28	60SK28	SK	7.110	6.699	B									6.72	4.72
30	60SK30	SK	7.590	7.175	B									7.34	5.34
32	60SK32	SK	8.070	7.652	B									8.10	6.10
35	60SK35	SK	8.780	8.367	B									9.42	7.42
36	60SK36	SK	9.020	8.605	B									9.70	7.70
40	60SK40	SK	9.980	9.559	B	2 5/8	2 7/8	2 1/8	3 7/8	1 27/64	51/64	1 1/4	.459	11.56	9.56
42	60SF42	SF	10.460	10.036	B	2 15/16	2 3/4	2 1/4	4 5/8	1 35/64	51/64	1 1/4	.459	13.78	10.78
45	60SF45	SF	11.180	10.752	B									15.40	12.40
48	60SF48	SF	11.890	11.467	B									17.26	14.26
54	60SF54	SF	13.330	12.899	B									20.02	17.02
60	60SF60	SF	14.760	14.331	B									23.76	20.76
70	60SF70	SF	17.150	16.717	B									31.60	28.60
72	60SF72	SF	17.630	17.194	B									32.58	29.58
80	60SF80	SF	19.540	19.103	B									41.24	38.24
84	60SF84	SF	20.490	20.058	B									43.94	40.94
96	60SF96	SF	23.360	22.922	B	2 15/16	2 3/4	2 1/4	4 5/8	1 35/64	51/64	1 1/4	.459	55.40	52.40
112	60E112	E	27.180	26.742	B1	3 1/2	2 5/8	2 15/16	6	2 3/16	1 11/64	1 5/8	.459	83.76	73.76

Sprockets

# No.60-2

# No.60-3 | Sprockets with QD Bushings



- Pitch  $3/4"$   Roller  $\phi$   $0.468"$
- Tooth width b1  $0.444"$   Tooth width B2  $1.341"$   Tooth width B3  $2.238"$

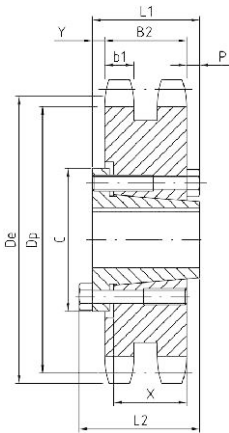

QD-TYPE C1

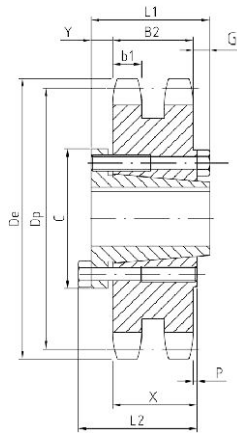

QD-TYPE C2

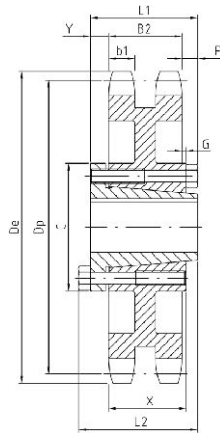

QD-TYPE C4

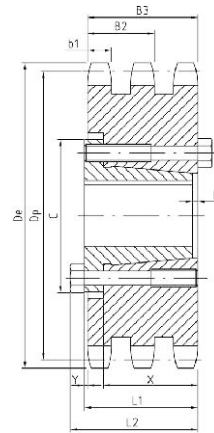

QD-TYPE B2

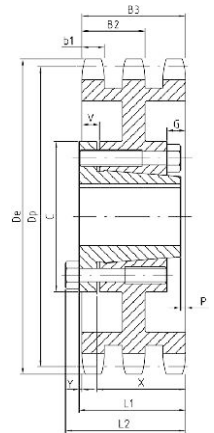

QD-TYPE C1

## Double-Type "QD"

No. Teeth	Part Number	Bushing	De	Dp	Type	Max. Bore	L1	L2	C	Y	P	G	X	b1	B2	Weight(Approx.)	
																With Hub	Rim Only
14	D60SH14H	SH	3.740	3.371	B★	1 <sup>5</sup> / <sub>8</sub>	1 <sup>1</sup> / <sub>32</sub>	1 <sup>3</sup> / <sub>32</sub>	2 <sup>7</sup> / <sub>16</sub>	1/2				.444	1.341	2.5	1.5
22	D60SDS22H	SDS	5.670	5.270	B★	2	1 <sup>7</sup> / <sub>32</sub>	1 <sup>5</sup> / <sub>32</sub>	3 <sup>3</sup> / <sub>16</sub>				3/4	.444	1.341	5.44	4.44
36	D60SF36	SF	9.020	8.605	C1	2 <sup>19</sup> / <sub>16</sub>	2	2 <sup>7</sup> / <sub>4</sub>	4 <sup>9</sup> / <sub>8</sub>	3/4			1 <sup>1</sup> / <sub>4</sub>	.444	1.341	19.26	16.26
42	D60E42	E	10.460	10.036	C2	3 <sup>1</sup> / <sub>2</sub>	2 <sup>5</sup> / <sub>8</sub>	2 <sup>19</sup> / <sub>16</sub>	6	7/8	1 <sup>3</sup> / <sub>32</sub>	9/32	1 <sup>5</sup> / <sub>8</sub>	.444	1.341	34.04	24.04
45	D60E45	E	11.180	10.752	C2											38.26	28.36
52	D60E52	E	12.850	12.422	C2											49.52	39.52
60	D60E60	E	14.760	14.331	C2											63.39	53.74
68	D60E68	E	16.670	16.240	C4											54.32	44.32
76	D60E76	E	18.580	18.149	C4											61.48	51.48
95	D60E95	E	23.120	22.683	C4	3 <sup>1</sup> / <sub>2</sub>	2 <sup>5</sup> / <sub>8</sub>	2 <sup>19</sup> / <sub>16</sub>	6	7/8	1 <sup>3</sup> / <sub>32</sub>	9/32	1 <sup>5</sup> / <sub>8</sub>	.444	1.341	82.96	72.96

★Not illustrated. Dimensions listed correspond approximately to illustrations shown.

## Triple-Type "QD"

No. Teeth	Part Number	Bushing	De	Dp	Type	Max. Bore	L1	L2	C	Y	P	G	V	X	b1	B3	Weight(Approx.)	
																	With Hub	Rim Only
36	E60E36	E	9.020	8.605	B2	3 <sup>1</sup> / <sub>2</sub>	2 <sup>5</sup> / <sub>8</sub>	2 <sup>15</sup> / <sub>16</sub>	6	1 <sup>7</sup> / <sub>64</sub>	1/8			1 <sup>5</sup> / <sub>8</sub>	.444	2.238	49	37
42	E60E42	E	10.460	10.036	B2	3 <sup>1</sup> / <sub>2</sub>	2 <sup>5</sup> / <sub>8</sub>	2 <sup>15</sup> / <sub>16</sub>	6	1 <sup>7</sup> / <sub>64</sub>	1/8			1 <sup>5</sup> / <sub>8</sub>	.444	2.238	62	50
52	E60E52	E	12.850	12.422	B2	3 <sup>1</sup> / <sub>2</sub>	2 <sup>5</sup> / <sub>8</sub>	2 <sup>15</sup> / <sub>16</sub>	6	1 <sup>7</sup> / <sub>64</sub>	1/8			1 <sup>5</sup> / <sub>8</sub>	.444	2.238	80	68
68	E60E68	E	16.670	16.240	C1	3 <sup>1</sup> / <sub>2</sub>	2 <sup>19</sup> / <sub>16</sub>	2 <sup>7</sup> / <sub>64</sub>	6	9/16	3/16	1/8	5/16	1 <sup>5</sup> / <sub>8</sub>	.444	2.238	83	71
76	E60E76	E	18.580	18.149	C1	3 <sup>1</sup> / <sub>2</sub>	2 <sup>19</sup> / <sub>16</sub>	2 <sup>7</sup> / <sub>64</sub>	6	9/16	3/16	1/8	5/16	1 <sup>5</sup> / <sub>8</sub>	.444	2.238	99	87
95	E60E95	E	23.120	22.683	C1	3 <sup>1</sup> / <sub>2</sub>	2 <sup>19</sup> / <sub>16</sub>	2 <sup>7</sup> / <sub>64</sub>	6	9/16	3/16	1/8	5/16	1 <sup>5</sup> / <sub>8</sub>	.444	2.238	129	117

Sprockets

# No.80 | Sprockets with QD Bushings |

- Pitch **1"**
- Roller  $\phi$  **0.625"**
- Tooth width B1 **0.575"**

## Single-Type "QD" With Hardened Teeth

No. Teeth	Part Number
11	80SH11H
12	80SH12H
13	80SDS13H
14	80SDS14H
15	80SK15H
16	80SK16H
17	80SK17H
18	80SK18H
19	80SK19H
20	80SF20H
21	80SF21H
22	80SF22H
23	80SF23H
24	80SF24H
25	80SF25H
26	80SF26H
27	80SF27H
28	80SF28H
30	80SF30H

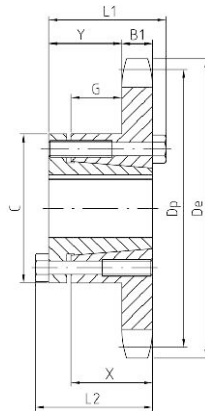

QD-TYPE B

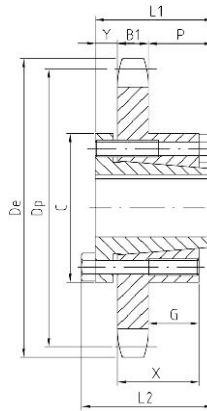

QD-TYPE C



## Single-Type "QD"

No. Teeth	Part Number	Bushing	De	Dp	Type	Max. Bore	L1	L2	C	Y	P	G	X	B1	Weight(Approx.)	
															With Hub	Rim Only
11	80SH11	SH	4.010	3.550	B	1 <sup>7</sup> / <sub>8</sub>	1 <sup>7</sup> / <sub>16</sub>	1 <sup>7</sup> / <sub>16</sub>	2 <sup>7</sup> / <sub>16</sub>	2 <sup>1</sup> / <sub>32</sub>		1 <sup>5</sup> / <sub>64</sub>	1 <sup>3</sup> / <sub>16</sub>	.575	2.0	1.0
12	80SH12	SH	4.330	3.864	B	1 <sup>7</sup> / <sub>8</sub>	1 <sup>7</sup> / <sub>16</sub>	1 <sup>7</sup> / <sub>16</sub>	2 <sup>7</sup> / <sub>16</sub>	2 <sup>1</sup> / <sub>32</sub>		1 <sup>5</sup> / <sub>64</sub>	1 <sup>3</sup> / <sub>16</sub>	.575	2.4	1.4
13	80SDS13	SDS	4.660	4.179	B	2	1 <sup>1</sup> / <sub>2</sub>	1 <sup>1</sup> / <sub>2</sub>	3 <sup>3</sup> / <sub>16</sub>	4 <sup>7</sup> / <sub>64</sub>		1 <sup>1</sup> / <sub>64</sub>	3 <sup>1</sup> / <sub>4</sub>	.575	2.5	1.5
14	80SDS14	SDS	4.980	4.494	B	2	1 <sup>1</sup> / <sub>2</sub>	1 <sup>1</sup> / <sub>2</sub>	3 <sup>3</sup> / <sub>16</sub>	4 <sup>7</sup> / <sub>64</sub>		1 <sup>1</sup> / <sub>64</sub>	3 <sup>1</sup> / <sub>4</sub>	.575	2.8	1.8
15	80SK15	S K	5.300	4.810	B	2 <sup>5</sup> / <sub>8</sub>	2 <sup>7</sup> / <sub>8</sub>	2 <sup>7</sup> / <sub>8</sub>	3 <sup>7</sup> / <sub>8</sub>	1 <sup>19</sup> / <sub>64</sub>		2 <sup>1</sup> / <sub>32</sub>	1 <sup>1</sup> / <sub>4</sub>	.575	4.5	2.5
16	80SK16	S K	5.630	5.126	B										5.1	3.1
17	80SK17	S K	5.950	5.442	B										5.5	3.5
18	80SK18	S K	6.270	5.759	B										5.9	3.9
19	80SK19	S K	6.590	6.076	B	2 <sup>5</sup> / <sub>8</sub>	2 <sup>7</sup> / <sub>8</sub>	2 <sup>7</sup> / <sub>8</sub>	3 <sup>7</sup> / <sub>8</sub>	1 <sup>19</sup> / <sub>64</sub>		2 <sup>1</sup> / <sub>32</sub>	1 <sup>1</sup> / <sub>4</sub>	.575	6.4	4.4
20	80SF20	SF	6.910	6.392	B	2 <sup>15</sup> / <sub>16</sub>	2 <sup>7</sup> / <sub>4</sub>	2 <sup>7</sup> / <sub>4</sub>	4 <sup>7</sup> / <sub>8</sub>	1 <sup>27</sup> / <sub>64</sub>		2 <sup>1</sup> / <sub>32</sub>	1 <sup>1</sup> / <sub>4</sub>	.575	8.3	5.3
21	80SF21	SF	7.240	6.710	B										8.7	5.7
22	80SF22	SF	7.560	7.027	B										9.3	6.3
23	80SF23	SF	7.880	7.344	B										9.8	6.8
24	80SF24	SF	8.200	7.661	B										10.5	7.5
25	80SF25	SF	8.520	7.979	B										11.0	8.0
26	80SF26	SF	8.840	8.296	B										11.6	8.6
27	80SF27	SF	9.160	8.614	B										12.4	9.4
28	80SF28	SF	9.480	8.931	B										13.2	10.2
30	80SF30	SF	10.110	9.567	B										14.3	11.3
32	80SF32	SF	10.750	10.202	B										16.0	13.0
33	80SF33	SF	11.070	10.520	B										16.5	13.5
34	80SF34	SF	11.390	10.838	B										17.1	14.1
35	80SF35	SF	11.710	11.156	B										18.5	15.5
36	80SF36	SF	12.030	11.474	B										19.9	16.9
40	80SF40	SF	13.310	12.746	B										23.6	20.6
42	80SF42	SF	13.940	13.382	B										25.4	22.4
45	80SF45	SF	14.900	14.336	B										28.1	25.1
48	80SF48	SF	15.860	15.290	B										31.6	28.6
54	80SF54	SF	17.770	17.198	B										39.8	36.8
60	80SF60	SF	19.680	19.107	B	2 <sup>15</sup> / <sub>16</sub>	2 <sup>7</sup> / <sub>4</sub>	2 <sup>7</sup> / <sub>4</sub>	4 <sup>7</sup> / <sub>8</sub>	1 <sup>27</sup> / <sub>64</sub>		2 <sup>1</sup> / <sub>32</sub>	1 <sup>1</sup> / <sub>4</sub>	.575	48.8	45.8
70	80E70	E	22.870	22.289	C	3 <sup>1</sup> / <sub>2</sub>	2 <sup>5</sup> / <sub>8</sub>	2 <sup>15</sup> / <sub>16</sub>	6	7 <sup>7</sup> / <sub>8</sub>	1 <sup>3</sup> / <sub>16</sub>	1 <sup>3</sup> / <sub>64</sub>	1 <sup>5</sup> / <sub>8</sub>	.575	65.6	55.6
72	80E72	E	23.500	22.926	C										69.3	59.3
80	80E80	E	26.050	25.471	C										79.2	69.2
84	80E84	E	27.330	26.744	C										84.9	74.9
96	80E96	E	31.150	30.563	C	3 <sup>1</sup> / <sub>2</sub>	2 <sup>5</sup> / <sub>8</sub>	2 <sup>15</sup> / <sub>16</sub>	6	7 <sup>7</sup> / <sub>8</sub>	1 <sup>3</sup> / <sub>16</sub>	1 <sup>3</sup> / <sub>64</sub>	1 <sup>5</sup> / <sub>8</sub>	.575	108	97.5
112	80E112	F	36.240	35.655	C	3 <sup>1</sup> / <sub>16</sub>	3 <sup>3</sup> / <sub>8</sub>	4	6 <sup>5</sup> / <sub>8</sub>	1	2 <sup>1</sup> / <sub>16</sub>	1 <sup>59</sup> / <sub>64</sub>	2 <sup>1</sup> / <sub>2</sub>	.575	145	134

# No.80-2

# No.80-3 | Sprockets with QD Bushings



- Pitch 1"
- Roller  $\phi$  0.625"
- Tooth width b1 0.557"
- Tooth width B2 1.710"
- Tooth width B3 2.863"

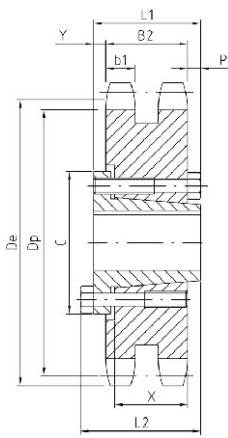

QD-TYPE C1

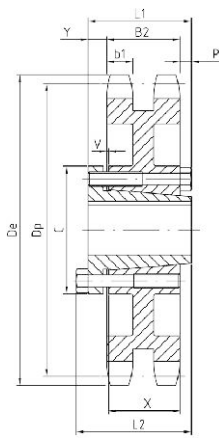

QD-TYPE C3

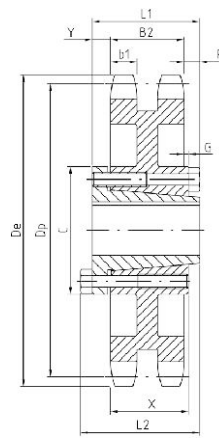

QD-TYPE C4

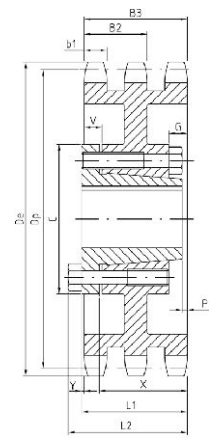

QD-TYPE B2

## Double-Type "QD"

No. Teeth	Part Number	Bushing	De	Dp	Type	Max. Bore	L1	L2	C	Y	P	G	V	X	b1	B2	Weight(Approx.)	
																	With Hub	Rim Only
36	D80E36	E	12.030	11.474	C1	3 <sup>1</sup> / <sub>2</sub>	2 <sup>5</sup> / <sub>8</sub>	2 <sup>19</sup> / <sub>16</sub>	6	5 <sup>1</sup> / <sub>64</sub>	1 <sup>1</sup> / <sub>8</sub>			1 <sup>5</sup> / <sub>8</sub>	.557	1.710	48.3	38.2
42	D80E42	E	13.940	13.382	C1	3 <sup>1</sup> / <sub>2</sub>	2 <sup>5</sup> / <sub>8</sub>	2 <sup>19</sup> / <sub>16</sub>	6	5 <sup>1</sup> / <sub>64</sub>	1 <sup>1</sup> / <sub>8</sub>			1 <sup>5</sup> / <sub>8</sub>	.557	1.710	65.3	55.3
45	D80E45	E	14.900	14.336	C1	3 <sup>1</sup> / <sub>2</sub>	2 <sup>5</sup> / <sub>8</sub>	2 <sup>19</sup> / <sub>16</sub>	6	5 <sup>1</sup> / <sub>64</sub>	1 <sup>1</sup> / <sub>8</sub>			1 <sup>5</sup> / <sub>8</sub>	.557	1.710	74.6	64.6
52	D80E52	E	17.130	16.562	C3	3 <sup>1</sup> / <sub>2</sub>	2 <sup>5</sup> / <sub>8</sub>	2 <sup>19</sup> / <sub>16</sub>	6	5 <sup>1</sup> / <sub>64</sub>	1 <sup>1</sup> / <sub>8</sub>		3 <sup>1</sup> / <sub>32</sub>	1 <sup>5</sup> / <sub>8</sub>	.557	1.710	68.2	58.2
60	D80E60	E	19.680	19.107	C3	3 <sup>1</sup> / <sub>2</sub>	2 <sup>5</sup> / <sub>8</sub>	2 <sup>19</sup> / <sub>16</sub>	6	5 <sup>1</sup> / <sub>64</sub>	1 <sup>1</sup> / <sub>8</sub>		3 <sup>1</sup> / <sub>32</sub>	1 <sup>5</sup> / <sub>8</sub>	.557	1.710	78.2	68.2
68	D80E68	E	22.230	21.653	C3	3 <sup>1</sup> / <sub>2</sub>	2 <sup>5</sup> / <sub>8</sub>	2 <sup>19</sup> / <sub>16</sub>	6	5 <sup>1</sup> / <sub>64</sub>	1 <sup>1</sup> / <sub>8</sub>		3 <sup>1</sup> / <sub>32</sub>	1 <sup>5</sup> / <sub>8</sub>	.557	1.710	84.2	74.2
76	D80E76	E	24.780	24.198	C3	3 <sup>1</sup> / <sub>2</sub>	2 <sup>5</sup> / <sub>8</sub>	2 <sup>19</sup> / <sub>16</sub>	6	5 <sup>1</sup> / <sub>64</sub>	1 <sup>1</sup> / <sub>8</sub>		3 <sup>1</sup> / <sub>32</sub>	1 <sup>5</sup> / <sub>8</sub>	.557	1.710	100	90.1
95	D80F95	F	30.830	30.245	C4	3 <sup>5</sup> / <sub>16</sub>	3 <sup>5</sup> / <sub>8</sub>	4	6 <sup>5</sup> / <sub>8</sub>	1	5 <sup>9</sup> / <sub>64</sub>	5 <sup>1</sup> / <sub>64</sub>		2 <sup>1</sup> / <sub>2</sub>	.557	1.710	152	140

## Triple-Type "QD"

No. Teeth	Part Number	Bushing	De	Dp	Type	Max. Bore	L1	L2	C	Y	P	G	V	X	b1	B3	Weight(Approx.)	
																	With Hub	Rim Only
36	E80E36	E	12.030	11.474	B2	3 <sup>1</sup> / <sub>2</sub>	3 <sup>7</sup> / <sub>64</sub>	3 <sup>27</sup> / <sub>64</sub>	6	1 <sup>1</sup> / <sub>4</sub>	3 <sup>1</sup> / <sub>64</sub>	1 <sup>1</sup> / <sub>8</sub>	5 <sup>1</sup> / <sub>8</sub>	1 <sup>5</sup> / <sub>8</sub>	.557	2.863	65.1	55.1
42	E80E42	E	13.940	13.382	B2	3 <sup>1</sup> / <sub>2</sub>	3 <sup>7</sup> / <sub>64</sub>	3 <sup>27</sup> / <sub>64</sub>	6	1 <sup>1</sup> / <sub>4</sub>	3 <sup>1</sup> / <sub>64</sub>	1 <sup>1</sup> / <sub>8</sub>	5 <sup>1</sup> / <sub>8</sub>	1 <sup>5</sup> / <sub>8</sub>	.557	2.863	81.9	71.9
45	E80E45	E	14.900	14.336	B2	3 <sup>1</sup> / <sub>2</sub>	3 <sup>7</sup> / <sub>64</sub>	3 <sup>27</sup> / <sub>64</sub>	6	1 <sup>1</sup> / <sub>4</sub>	3 <sup>1</sup> / <sub>64</sub>	1 <sup>1</sup> / <sub>8</sub>	5 <sup>1</sup> / <sub>8</sub>	1 <sup>5</sup> / <sub>8</sub>	.557	2.863	75.3	65.3
52	E80E52	E	17.130	16.562	B2	3 <sup>1</sup> / <sub>2</sub>	3 <sup>7</sup> / <sub>64</sub>	3 <sup>27</sup> / <sub>64</sub>	6	1 <sup>1</sup> / <sub>4</sub>	3 <sup>1</sup> / <sub>64</sub>	1 <sup>1</sup> / <sub>8</sub>	5 <sup>1</sup> / <sub>8</sub>	1 <sup>5</sup> / <sub>8</sub>	.557	2.863	90.0	80.0
60	E80F60	F	19.680	19.107	B2	3 <sup>15</sup> / <sub>16</sub>	3 <sup>49</sup> / <sub>64</sub>	4 <sup>3</sup> / <sub>64</sub>	6 <sup>5</sup> / <sub>8</sub>	1 <sup>3</sup> / <sub>16</sub>	3 <sup>1</sup> / <sub>64</sub>	1 <sup>1</sup> / <sub>8</sub>	3 <sup>1</sup> / <sub>16</sub>	2 <sup>1</sup> / <sub>2</sub>	.557	2.863	112	100
68	E80F68	F	22.230	21.653	B2	3 <sup>15</sup> / <sub>16</sub>	3 <sup>49</sup> / <sub>64</sub>	4 <sup>3</sup> / <sub>64</sub>	6 <sup>5</sup> / <sub>8</sub>	1 <sup>3</sup> / <sub>16</sub>	3 <sup>1</sup> / <sub>64</sub>	1 <sup>1</sup> / <sub>8</sub>	3 <sup>1</sup> / <sub>16</sub>	2 <sup>1</sup> / <sub>2</sub>	.557	2.863	132	120
76	E80F76	F	24.780	24.198	B2	3 <sup>15</sup> / <sub>16</sub>	3 <sup>49</sup> / <sub>64</sub>	4 <sup>3</sup> / <sub>64</sub>	6 <sup>5</sup> / <sub>8</sub>	1 <sup>3</sup> / <sub>16</sub>	3 <sup>1</sup> / <sub>64</sub>	1 <sup>1</sup> / <sub>8</sub>	3 <sup>1</sup> / <sub>16</sub>	2 <sup>1</sup> / <sub>2</sub>	.557	2.863	150	138
95	E80F95	F	30.830	30.245	B2	3 <sup>15</sup> / <sub>16</sub>	3 <sup>49</sup> / <sub>64</sub>	4 <sup>3</sup> / <sub>64</sub>	6 <sup>5</sup> / <sub>8</sub>	1 <sup>3</sup> / <sub>16</sub>	3 <sup>1</sup> / <sub>64</sub>	1 <sup>1</sup> / <sub>8</sub>	3 <sup>1</sup> / <sub>16</sub>	2 <sup>1</sup> / <sub>2</sub>	.557	2.863	208	196

Sprockets



**GOODWILL**

# No.100 | Sprockets with QD Bushings

- Pitch  $1\frac{1}{4}''$   Roller  $\phi$   $0.750''$
- Tooth width B1  $0.692''$

## Single-Type "QD" With Hardened Teeth

No. Teeth	Part Number
11	100SDS11H
12	100SDS12H
13	100SK13H
14	100SD14H
15	100SF15H
16	100SF16H
17	100SF17H
18	100E18H
19	100E19H
20	100E20H
21	100E21H
22	100E22H
23	100E23H
24	100E24H
25	100E25H
26	100E26H
27	100E27H
28	100E28H
30	100E30H

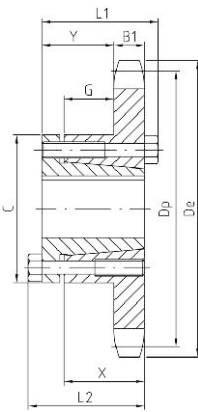

QD-TYPE B

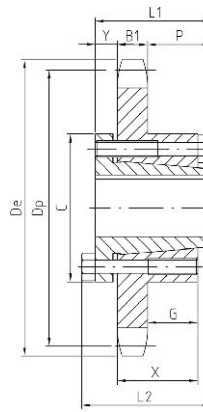

QD-TYPE C

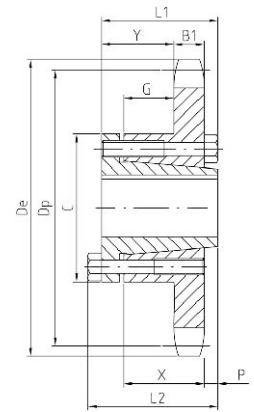

QD-TYPE B1

## Single-Type "QD"

No. Teeth	Part Number	Bushing	De	Dp	Type	Max. Bore	L1	L2	C	Y	P	G	X	B1	Weight(Approx.)	
															With Hub	Rim Only
11	100SDS11	SDS	5.010	4.437	B	2	1½	1½	3 <sup>7</sup> / <sub>16</sub>	5/8		1/16	3/4	.692	3.0	2.0
12	100SDS12	SDS	5.420	4.830	B	2	1½	1½	3 <sup>7</sup> / <sub>16</sub>	5/8		1/16	3/4	.692	3.6	2.6
13	100SK13	SK	5.820	5.223	B	2 <sup>5</sup> / <sub>8</sub>	2 <sup>7</sup> / <sub>8</sub>	1 <sup>1</sup> / <sub>8</sub>	3 <sup>7</sup> / <sub>8</sub>	1 <sup>3</sup> / <sub>64</sub>		9/16	1 <sup>1</sup> / <sub>4</sub>	.692	5.3	3.3
14	100SK14	SK	6.230	5.617	B	2 <sup>5</sup> / <sub>8</sub>	2 <sup>7</sup> / <sub>8</sub>	1 <sup>1</sup> / <sub>8</sub>	3 <sup>7</sup> / <sub>8</sub>	1 <sup>3</sup> / <sub>64</sub>		9/16	1 <sup>1</sup> / <sub>4</sub>	.692	6.1	4.1
15	100SF15	SF	6.630	6.012	B	2 <sup>9</sup> / <sub>16</sub>	2 <sup>1</sup> / <sub>4</sub>	1 <sup>1</sup> / <sub>4</sub>	4 <sup>5</sup> / <sub>8</sub>	1 <sup>9</sup> / <sub>64</sub>		9/16	1 <sup>1</sup> / <sub>4</sub>	.692	7.8	4.8
16	100SF16	SF	7.030	6.407	B	2 <sup>9</sup> / <sub>16</sub>	2 <sup>1</sup> / <sub>4</sub>	1 <sup>1</sup> / <sub>4</sub>	4 <sup>5</sup> / <sub>8</sub>	1 <sup>9</sup> / <sub>64</sub>		9/16	1 <sup>1</sup> / <sub>4</sub>	.692	8.6	5.6
17	100SF17	SF	7.440	6.803	B	2 <sup>9</sup> / <sub>16</sub>	2 <sup>1</sup> / <sub>4</sub>	1 <sup>1</sup> / <sub>4</sub>	4 <sup>5</sup> / <sub>8</sub>	1 <sup>9</sup> / <sub>64</sub>		9/16	1 <sup>1</sup> / <sub>4</sub>	.692	9.5	6.5
18	100E18	E	7.840	7.198	B1	3½	2 <sup>7</sup> / <sub>8</sub>	2 <sup>9</sup> / <sub>16</sub>	6	1 <sup>3</sup> / <sub>16</sub>	1/8	15/16	1 <sup>5</sup> / <sub>8</sub>	.692	19.0	9.0
19	100E19	E	8.240	7.595	B1										20.2	10.2
20	100E20	E	8.640	7.991	B1										21.6	11.6
21	100E21	E	9.040	8.387	B1										22.5	12.5
22	100E22	E	9.440	8.783	B1										23.5	13.5
23	100E23	E	9.840	9.180	B1										24.6	14.6
24	100E24	E	10.250	9.577	B1										25.7	15.7
25	100E25	E	10.650	9.973	B1										26.8	16.8
26	100E26	E	11.050	10.370	B1										28.1	18.1
27	100E27	E	11.440	10.767	B1										29.2	19.2
28	100E28	E	11.840	11.164	B1										30.7	20.7
30	100E30	E	12.640	11.958	B1										33.2	23.2
32	100E32	E	13.440	12.753	B1										35.4	25.4
35	100E35	E	14.640	13.945	B1										40.5	30.5
36	100E36	E	15.040	14.342	B1										42.5	32.3
40	100E40	E	16.630	15.931	B1										49.1	39.1
42	100E42	E	17.430	16.727	B1										53.4	43.4
45	100E45	E	18.630	17.920	B1										58.9	48.9
48	100E48	E	19.820	19.112	B1	3½	2 <sup>7</sup> / <sub>8</sub>	2 <sup>9</sup> / <sub>16</sub>	6	1 <sup>3</sup> / <sub>16</sub>	1/8	15/16	1 <sup>5</sup> / <sub>8</sub>	.692	64.0	54.0
54	100E54	E	22.210	21.498	C	3½	2 <sup>7</sup> / <sub>8</sub>	2 <sup>9</sup> / <sub>16</sub>	6	7/8	1 1/16	15/16	1 <sup>5</sup> / <sub>8</sub>	.692	72.0	62.0
60	100E60	E	24.600	23.884	C	3½	2 <sup>7</sup> / <sub>8</sub>	2 <sup>9</sup> / <sub>16</sub>	6	7/8	1 1/16	15/16	1 <sup>5</sup> / <sub>8</sub>	.692	84.0	74.0
70	100F70	F	28.580	27.862	C	3 <sup>9</sup> / <sub>16</sub>	3 <sup>3</sup> / <sub>8</sub>	4	6 <sup>5</sup> / <sub>8</sub>	1	1 <sup>15</sup> / <sub>16</sub>	1 <sup>15</sup> / <sub>16</sub>	2 <sup>1</sup> / <sub>2</sub>	.692	110.5	99.0
72	100F72	F	29.380	28.657	C										117.5	106
80	100F80	F	32.570	31.839	C										134.5	123
84	100F84	F	34.160	33.430	C	3 <sup>9</sup> / <sub>16</sub>	3 <sup>3</sup> / <sub>8</sub>	4	6 <sup>5</sup> / <sub>8</sub>	1	1 <sup>15</sup> / <sub>16</sub>	1 <sup>15</sup> / <sub>16</sub>	2 <sup>1</sup> / <sub>2</sub>	.692	151.5	140

Sprockets

# No.100-2

# No.100-3 | Sprockets with QD Bushings



- Pitch  $1\frac{1}{4}''$
- Roller  $\phi$  0.750''
- Tooth width b1 0.669''
- Tooth width B2 2.077''
- Tooth width B3 3.485''

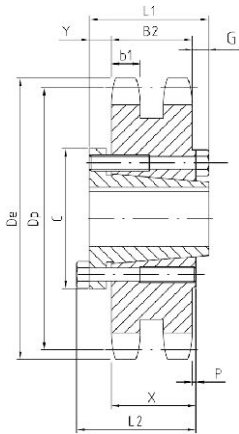

QD-TYPE C2

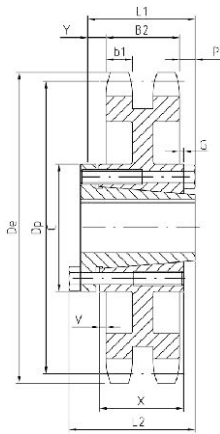

QD-TYPE C6

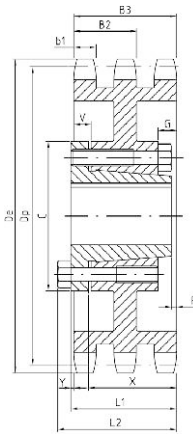

QD-TYPE B2

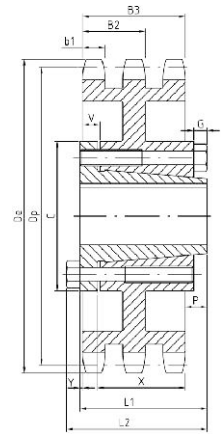

QD-TYPE C3

## Double-Type "QD"

No. Teeth	Part Number	Bushing	De	Dp	Type	Max. Bore	L1	L2	C	Y	P	G	V	X	b1	B2	Weight(Approx.)	
																	With Hub	Rim Only
35	D100F35	F	14.640	13.945	C2	3 <sup>9</sup> / <sub>16</sub>	3 <sup>9</sup> / <sub>8</sub>	4	6 <sup>9</sup> / <sub>8</sub>	1	3 <sup>9</sup> / <sub>64</sub>	2 <sup>7</sup> / <sub>64</sub>		2 <sup>1</sup> / <sub>2</sub>	.669	2.077	84.5	73
45	D100F45	F	18.630	17.920	C2	3 <sup>9</sup> / <sub>16</sub>	3 <sup>9</sup> / <sub>8</sub>	4	6 <sup>9</sup> / <sub>8</sub>	1	3 <sup>9</sup> / <sub>64</sub>	2 <sup>7</sup> / <sub>64</sub>		2 <sup>1</sup> / <sub>2</sub>	.669	2.077	92.5	81
60	D100J60	J	24.600	23.884	C6	4 <sup>7</sup> / <sub>16</sub>	4 <sup>1</sup> / <sub>2</sub>	5	7 <sup>1</sup> / <sub>4</sub>	1 <sup>7</sup> / <sub>32</sub>	1 <sup>9</sup> / <sub>64</sub>	1 <sup>3</sup> / <sub>32</sub>	1 <sup>1</sup> / <sub>32</sub>	3 <sup>3</sup> / <sub>16</sub>	.669	2.077	152	133
70	D100J70	J	28.580	27.862	C6	4 <sup>7</sup> / <sub>16</sub>	4 <sup>1</sup> / <sub>2</sub>	5	7 <sup>1</sup> / <sub>4</sub>	1 <sup>7</sup> / <sub>32</sub>	1 <sup>9</sup> / <sub>64</sub>	1 <sup>3</sup> / <sub>32</sub>	1 <sup>1</sup> / <sub>32</sub>	3 <sup>3</sup> / <sub>16</sub>	.669	2.077	180	161
80	D100J80	J	32.570	31.839	C6	4 <sup>7</sup> / <sub>16</sub>	4 <sup>1</sup> / <sub>2</sub>	5	7 <sup>1</sup> / <sub>4</sub>	1 <sup>7</sup> / <sub>32</sub>	1 <sup>9</sup> / <sub>64</sub>	1 <sup>3</sup> / <sub>32</sub>	1 <sup>1</sup> / <sub>32</sub>	3 <sup>3</sup> / <sub>16</sub>	.669	2.077	215	196

## Triple-Type "QD"

No. Teeth	Part Number	Bushing	De	Dp	Type	Max. Bore	L1	L2	C	Y	P	G	V	X	B1	B3	Weight(Approx.)	
																	With Hub	Rim Only
35	E100F35	F	14.640	13.945	B2	3 <sup>9</sup> / <sub>16</sub>	3 <sup>23</sup> / <sub>64</sub>	4 <sup>23</sup> / <sub>64</sub>	6 <sup>9</sup> / <sub>8</sub>	1 <sup>1</sup> / <sub>2</sub>	2 <sup>23</sup> / <sub>64</sub>	1 <sup>1</sup> / <sub>8</sub>	1 <sup>1</sup> / <sub>2</sub>	2 <sup>1</sup> / <sub>2</sub>	.669	3.485	112	100
45	E100F45	F	18.630	17.820	B2	3 <sup>9</sup> / <sub>16</sub>	3 <sup>23</sup> / <sub>64</sub>	4 <sup>23</sup> / <sub>64</sub>	6 <sup>9</sup> / <sub>8</sub>	1 <sup>1</sup> / <sub>2</sub>	2 <sup>23</sup> / <sub>64</sub>	1 <sup>1</sup> / <sub>8</sub>	1 <sup>1</sup> / <sub>2</sub>	2 <sup>1</sup> / <sub>2</sub>	.669	3.485	139	120
60	E100J60	J	24.600	23.884	C3	4 <sup>7</sup> / <sub>16</sub>	4 <sup>1</sup> / <sub>2</sub>	5	7 <sup>1</sup> / <sub>4</sub>	1 <sup>1</sup> / <sub>2</sub>	3 <sup>33</sup> / <sub>64</sub>	3 <sup>1</sup> / <sub>8</sub>	1 <sup>11</sup> / <sub>16</sub>	3 <sup>3</sup> / <sub>16</sub>	.669	3.485	197	178
70	E100J70	J	28.580	27.862	C3	4 <sup>7</sup> / <sub>16</sub>	4 <sup>1</sup> / <sub>2</sub>	5	7 <sup>1</sup> / <sub>4</sub>	1 <sup>1</sup> / <sub>2</sub>	3 <sup>33</sup> / <sub>64</sub>	3 <sup>1</sup> / <sub>8</sub>	1 <sup>11</sup> / <sub>16</sub>	3 <sup>3</sup> / <sub>16</sub>	.669	3.485	247	228
80	E100J80	J	32.570	31.839	C3	4 <sup>7</sup> / <sub>16</sub>	4 <sup>1</sup> / <sub>2</sub>	5	7 <sup>1</sup> / <sub>4</sub>	1 <sup>1</sup> / <sub>2</sub>	3 <sup>33</sup> / <sub>64</sub>	3 <sup>1</sup> / <sub>8</sub>	1 <sup>11</sup> / <sub>16</sub>	3 <sup>3</sup> / <sub>16</sub>	.669	3.485	287	268

Sprockets



**GOODWILL**

# No.120 | Sprockets with QD Bushings

- Pitch  $1\frac{1}{2}''$  □ Roller  $\phi$   $0.875''$
- Tooth width B1  $0.924''$

## Single-Type "QD" With Hardened Teeth

No. Teeth	Part Number
12	120SF12H
13	120SF13H
14	120SF14H
15	120SF15H
16	120E16H
17	120E17H
18	120E18H
19	120E19H
20	120E20H
21	120E21H
22	120E22H
23	120E23H
24	120E24H
25	120E25H
26	120E26H
28	120E28H
30	120E30H

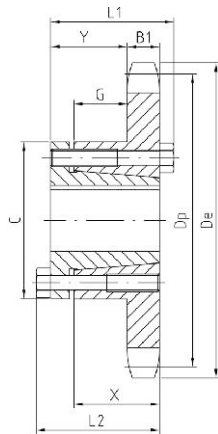

QD-TYPE B

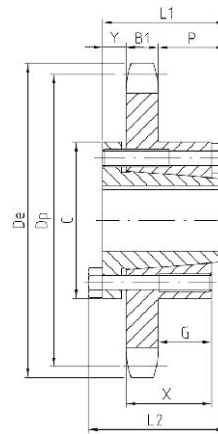

QD-TYPE C

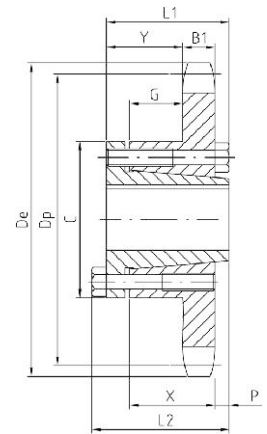

QD-TYPE B1

## Single-Type "QD"

No. Teeth	Part Number	Bushing	De	Dp	Type	Max. Bore	L1	L2	C	Y	P	G	X	B1	Weight(Approx.)		
															With Hub	Rim Only	
12	120SF12	SF	6.500	5.796	B	2 <sup>9</sup> / <sub>16</sub>	2 <sup>1</sup> / <sub>4</sub>	2 <sup>1</sup> / <sub>4</sub>	4 <sup>5</sup> / <sub>8</sub>	1 <sup>5</sup> / <sub>64</sub>		2 <sup>1</sup> / <sub>64</sub>	1 <sup>1</sup> / <sub>4</sub>	.924	7.7	4.7	
13	120SF13	SF	6.990	6.268	B											9.1	6.1
14	120SF14	SF	7.470	6.741	B											10.4	7.4
15	120SF15	SF	7.960	7.215	B	2 <sup>9</sup> / <sub>16</sub>	2 <sup>1</sup> / <sub>4</sub>	2 <sup>1</sup> / <sub>4</sub>	4 <sup>5</sup> / <sub>8</sub>	1 <sup>5</sup> / <sub>64</sub>		2 <sup>1</sup> / <sub>64</sub>	1 <sup>1</sup> / <sub>4</sub>	.924	11.8	8.0	
16	120E16	E	8.440	7.689	B1	3 <sup>1</sup> / <sub>2</sub>	2 <sup>5</sup> / <sub>8</sub>	2 <sup>9</sup> / <sub>16</sub>	6	1 <sup>9</sup> / <sub>16</sub>	1 <sup>1</sup> / <sub>8</sub>	4 <sup>5</sup> / <sub>64</sub>	1 <sup>5</sup> / <sub>8</sub>	.924	21.2	11.2	
17	120E17	E	8.920	8.163	B1										23.4	13.4	
18	120E18	E	9.410	8.638	B1										24.8	14.8	
19	120E19	E	9.890	9.113	B1										26.5	16.5	
20	120E20	E	10.370	9.589	B1										29.2	19.2	
21	120E21	E	10.850	10.064	B1										29.9	19.9	
22	120E22	E	11.330	10.540	B1										31.6	21.6	
23	120E23	E	11.810	11.016	B1										33.8	23.8	
24	120E24	E	12.290	11.492	B1										35.8	25.8	
25	120E25	E	12.770	11.968	B1										38.1	28.1	
26	120E26	E	13.250	12.444	B1										39.9	29.9	
28	120E28	E	14.210	13.397	B1										49.7	34.7	
30	120E30	E	15.170	14.350	B1	3 <sup>1</sup> / <sub>2</sub>	2 <sup>5</sup> / <sub>8</sub>	2 <sup>9</sup> / <sub>16</sub>	6	1 <sup>9</sup> / <sub>16</sub>	1 <sup>1</sup> / <sub>8</sub>	4 <sup>5</sup> / <sub>64</sub>	1 <sup>5</sup> / <sub>8</sub>	.924	49.4	39.4	
32	120F32	F	16.130	15.303	C	3 <sup>9</sup> / <sub>16</sub>	3 <sup>5</sup> / <sub>8</sub>	4	6 <sup>5</sup> / <sub>8</sub>	1	1 <sup>1</sup> / <sub>16</sub>	1 <sup>37</sup> / <sub>64</sub>	2 <sup>1</sup> / <sub>2</sub>	.924	62.0	50.5	
35	120F35	F	17.570	16.734	C										71.0	59.5	
36	120F36	F	18.050	17.211	C										74.9	63.4	
40	120F40	F	19.960	19.118	C										88.5	77.0	
42	120F42	F	20.920	20.072	C										94.5	83.0	
45	120F45	F	22.350	21.503	C										95.5	84.0	
48	120F48	F	23.790	22.935	C										103.5	92.0	
54	120F54	F	26.650	25.798	C	3 <sup>9</sup> / <sub>16</sub>	3 <sup>5</sup> / <sub>8</sub>	4	6 <sup>5</sup> / <sub>8</sub>	1	1 <sup>1</sup> / <sub>16</sub>	1 <sup>37</sup> / <sub>64</sub>	2 <sup>1</sup> / <sub>2</sub>	.924	125	114	
60	120J60	J	29.520	28.661	C	4 <sup>7</sup> / <sub>16</sub>	4 <sup>1</sup> / <sub>2</sub>	5	7 <sup>1</sup> / <sub>4</sub>	1 <sup>3</sup> / <sub>16</sub>	2 <sup>9</sup> / <sub>16</sub>	2 <sup>17</sup> / <sub>64</sub>	3 <sup>3</sup> / <sub>16</sub>	.924	159	140	
70	120J70	J	34.300	33.434	C	4 <sup>7</sup> / <sub>16</sub>	4 <sup>1</sup> / <sub>2</sub>	5	7 <sup>1</sup> / <sub>4</sub>	1 <sup>3</sup> / <sub>16</sub>	2 <sup>9</sup> / <sub>16</sub>	2 <sup>17</sup> / <sub>64</sub>	3 <sup>3</sup> / <sub>16</sub>	.924	196	177	
80	120J80	J	39.080	38.207	C	4 <sup>7</sup> / <sub>16</sub>	4 <sup>1</sup> / <sub>2</sub>	5	7 <sup>1</sup> / <sub>4</sub>	1 <sup>3</sup> / <sub>16</sub>	2 <sup>9</sup> / <sub>16</sub>	2 <sup>17</sup> / <sub>64</sub>	3 <sup>3</sup> / <sub>16</sub>	.924	241	222	

# No.140 | Sprockets with QD Bushings

- Pitch  $1\frac{3}{4}"$   Roller  $\phi$  1.000"
- Tooth width b1 0.924"

## Single-Type "QD" with Hardened Teeth

No. Teeth	Part Number
11	140SF11H
12	140SF12H
13	140SF13H
14	140E14H
15	140E15H
16	140E16H
17	140E17H
18	140E18H
19	140E19H
20	140E20H
21	140E21H
22	140E22H
23	140E23H
24	140E24H
25	140E25H
26	140E26H
30	140E30H

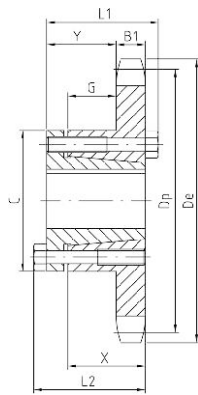

QD-TYPE B

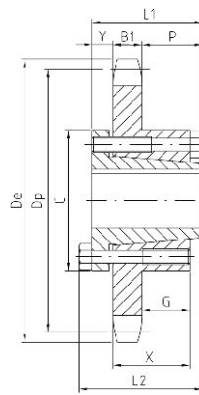

QD-TYPE C

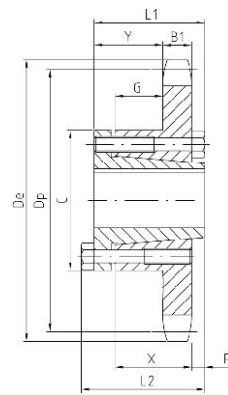

QD-TYPE B1

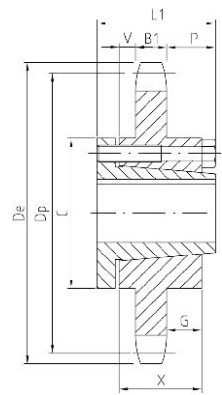

QD-TYPE C1

## Single-Taper Bushed

No. Teeth	Part Number	Bushing	De	Dp	Type	Max. Bore	L1	L2	C	Y	P	G	V	X	B1	Weight(Approx.)	
																With Hub	Rim Only
11	140SF11	SF	7.010	6.212	B	2 <sup>15</sup> / <sub>16</sub>	2 <sup>1</sup> / <sub>4</sub>	2 <sup>1</sup> / <sub>4</sub>	4 <sup>5</sup> / <sub>8</sub>	1 <sup>5</sup> / <sub>64</sub>		2 <sup>1</sup> / <sub>64</sub>		1 <sup>1</sup> / <sub>4</sub>	.924	8.6	5.6
12	140SF12	SF	7.580	6.762	B	2 <sup>15</sup> / <sub>16</sub>	2 <sup>1</sup> / <sub>4</sub>	2 <sup>1</sup> / <sub>4</sub>	4 <sup>5</sup> / <sub>8</sub>	1 <sup>5</sup> / <sub>64</sub>		2 <sup>1</sup> / <sub>64</sub>		1 <sup>1</sup> / <sub>4</sub>	.924	10.4	7.4
13	140SF13	SF	8.150	7.313	B	2 <sup>15</sup> / <sub>16</sub>	2 <sup>1</sup> / <sub>4</sub>	2 <sup>1</sup> / <sub>4</sub>	4 <sup>5</sup> / <sub>8</sub>	1 <sup>5</sup> / <sub>64</sub>		2 <sup>1</sup> / <sub>64</sub>		1 <sup>1</sup> / <sub>4</sub>	.924	11.9	8.9
14	140E14	E	8.720	7.864	B1	3 1/2	2 <sup>3</sup> / <sub>8</sub>	2 <sup>9</sup> / <sub>16</sub>	6	1 <sup>9</sup> / <sub>16</sub>	1/8	4 <sup>5</sup> / <sub>64</sub>		1 <sup>5</sup> / <sub>8</sub>	.924	21.6	11.6
15	140E15	E	9.280	8.417	B1											24.2	14.2
16	140E16	E	9.850	8.970	B1											25.9	15.9
17	140E17	E	10.410	9.524	B1											28.0	18.0
18	140E18	E	10.980	10.078	B1											29.6	19.6
19	140E19	E	11.540	10.632	B1											32.0	22.0
20	140E20	E	12.100	11.187	B1											34.6	24.6
21	140E21	E	12.660	11.742	B1											37.6	27.6
22	140E22	E	13.220	12.297	B1	3 1/2	2 <sup>3</sup> / <sub>8</sub>	2 <sup>9</sup> / <sub>16</sub>	6	1 <sup>9</sup> / <sub>16</sub>	1/8	4 <sup>5</sup> / <sub>64</sub>		1 <sup>5</sup> / <sub>8</sub>	.924	39.5	29.5
23	140F23	F	13.780	12.852	B1	3 <sup>5</sup> / <sub>16</sub>	3 <sup>3</sup> / <sub>8</sub>	4	6 <sup>5</sup> / <sub>8</sub>	2 <sup>9</sup> / <sub>16</sub>	1/8	1 <sup>37</sup> / <sub>64</sub>		2 <sup>1</sup> / <sub>2</sub>	.924	48.0	36.4
24	140F24	F	14.340	13.407	B1											51.6	40.1
25	140F25	F	14.900	13.963	B1											53.8	42.3
26	140F26	F	15.460	14.518	B1											58.0	46.5
30	140F30	F	17.700	16.742	B1	3 <sup>5</sup> / <sub>16</sub>	3 <sup>3</sup> / <sub>8</sub>	4	6 <sup>5</sup> / <sub>8</sub>	2 <sup>9</sup> / <sub>16</sub>	1/8	1 <sup>37</sup> / <sub>64</sub>		2 <sup>1</sup> / <sub>2</sub>	.924	72.0	60.4
35	140F35	F	20.490	19.523	C	3 <sup>5</sup> / <sub>16</sub>	3 <sup>3</sup> / <sub>8</sub>	4	6 <sup>5</sup> / <sub>8</sub>	1	1 <sup>11</sup> / <sub>16</sub>	1 <sup>37</sup> / <sub>64</sub>		2 <sup>1</sup> / <sub>2</sub>	.924	89.5	78.0
36	140F36	F	21.050	20.079	C	3 <sup>5</sup> / <sub>16</sub>	3 <sup>3</sup> / <sub>8</sub>	4	6 <sup>5</sup> / <sub>8</sub>	1	1 <sup>11</sup> / <sub>16</sub>	1 <sup>37</sup> / <sub>64</sub>		2 <sup>1</sup> / <sub>2</sub>	.924	95.5	84.0
40	140J40	J	23.290	22.305	C	4 7/16	4 <sup>1</sup> / <sub>2</sub>	5	7 <sup>1</sup> / <sub>4</sub>	1 <sup>1</sup> / <sub>16</sub>	2 3/8	2 <sup>17</sup> / <sub>64</sub>		3 <sup>3</sup> / <sub>16</sub>	.924	117	98.0
45	140J45	J	26.080	25.087	C											139	120
48	140J48	J	27.750	26.757	C											148	129
54	140J54	J	31.100	30.097	C											168	149
60	140J60	J	34.440	33.438	C	4 7/16	4 <sup>1</sup> / <sub>2</sub>	5	7 <sup>1</sup> / <sub>4</sub>	1 <sup>1</sup> / <sub>16</sub>	2 3/8	2 <sup>17</sup> / <sub>64</sub>		3 <sup>3</sup> / <sub>16</sub>	.924	205	186
70	140M70	M	40.020	39.006	C1	5 1/2	6 <sup>3</sup> / <sub>4</sub>	6 <sup>3</sup> / <sub>4</sub>	9	2 <sup>29</sup> / <sub>32</sub>	2 <sup>29</sup> / <sub>32</sub>	2 <sup>17</sup> / <sub>32</sub>	1 <sup>13</sup> / <sub>32</sub>	5 <sup>3</sup> / <sub>16</sub>	.924	301	264
80	140M80	M	45.590	44.575	C1	5 1/2	6 <sup>3</sup> / <sub>4</sub>	6 <sup>3</sup> / <sub>4</sub>	9	2 <sup>29</sup> / <sub>32</sub>	2 <sup>29</sup> / <sub>32</sub>	2 <sup>17</sup> / <sub>32</sub>	1 <sup>13</sup> / <sub>32</sub>	5 <sup>3</sup> / <sub>16</sub>	.924	385	348

Sprockets

# No.160 | Sprockets with QD Bushings

- Pitch 2"  Roller  $\phi$  1.125"
- Tooth width B1 1.156"

## Single-Type "QD" With Hardened Teeth

No. Teeth	Part Number
12	160E12H
13	160E13H
14	160E14H
15	160E15H
16	160E16H
17	160E17H
18	160E18H
19	160E19H
20	160E20H
21	160E21H
22	160E22H
23	160E23H
24	160E24H
25	160E25H
26	160E26H
28	160E28H
30	160E30H

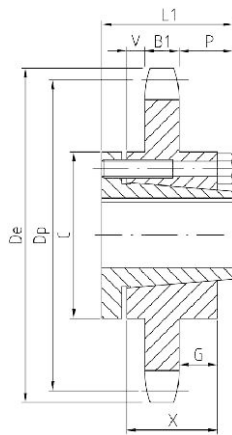

QD-TYPE C1

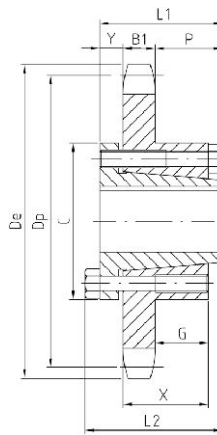

QD-TYPE C

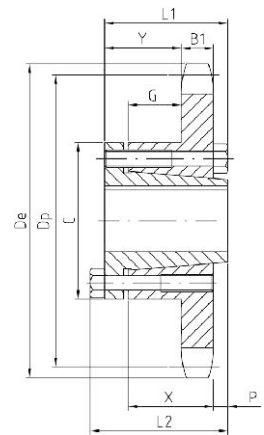

QD-TYPE B1

## Single-Type "QD"

No. Teeth	Part Number	Bushing	De	Dp	Type	Max. Bore	L1	L2	C	Y	P	G	V	X	B1	Weight(Approx.)	
																With Hub	Rim Only
12	140E12	E	8.660	7.727	B1	3 1/2	2 5/8	2 15/16	6	1 15/16	1/8	1 5/32		1 5/8	1.156	21.0	11
13	140E13	E	9.310	8.357	B1	3 1/2	2 5/8	2 15/16	6	1 15/16	1/8	1 5/32		1 5/8	1.156	24.0	14
14	140E14	E	9.960	8.988	B1	3 1/2	2 5/8	2 15/16	6	1 15/16	1/8	1 5/32		1 5/8	1.156	26.0	16
15	140F15	F	10.610	9.620	B1	3 9/16	3 3/8	4	6 9/8	2 5/16	1/8	1 11/32		2 1/2	1.156	35.5	24
16	140F16	F	11.260	10.252	B1											38.5	27
17	140F17	F	11.900	10.885	B1											42.5	31
18	140F18	F	12.540	11.518	B1											46.5	35
19	140F19	F	13.190	12.151	B1											49.5	38
20	140F20	F	13.830	12.785	B1											53.5	42
21	140F21	F	14.740	13.419	B1											56.5	45
22	140F22	F	15.110	14.053	B1											62.5	51
23	140F23	F	15.750	14.688	B1											66.5	55
24	140F24	F	16.390	15.323	B1											70.5	59
25	140F25	F	17.030	15.958	B1	3 9/16	3 3/8	4	6 9/8	2 5/16	1/8	1 11/32		2 1/2	1.156	75.5	64
26	140J26	J	17.670	16.593	C	4 7/16	4 1/2	5	7 1/4	1 3/16	2 1/8	2 1/32		3 3/16	1.156	92.5	74
28	140J30	J	18.950	17.863	C											103	84
30	160J30	J	20.230	19.134	C											115	96
35	140J35	J	23.420	22.312	C	4 7/16	4 1/2	5	7 1/4	1 3/16	2 1/8	2 1/32		3 3/16	1.156	135	116
40	140M40	M	26.610	25.491	C1	5 1/2	6 3/4	6 3/4	9	2 11/16	2 1/16	2 3/32	1 19/32	5 3/16	1.156	211	174
45	140M45	M	29.800	28.671	C1											245	208
54	140M54	M	35.540	34.397	C1											299	262
60	140M60	M	39.360	38.215	C1											347	310
70	140M70	M	45.730	44.578	C1											468	431
80	140M80	M	52.100	50.943	C1	5 1/2	6 3/4	6 3/4	9	2 11/16	2 1/16	2 3/32	1 19/32	5 3/16	1.156	567	530

# No. 120-2 No. 140-2 No. 160-2

## Sprockets with QD Bushings

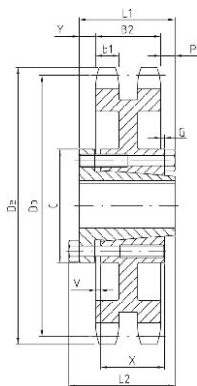

QD-TYPE C5

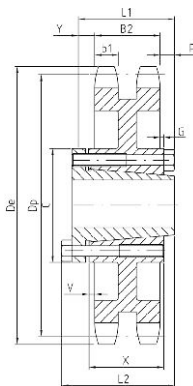

QD-TYPE C6

- Pitch  $1\frac{1}{2}''$
- Roller  $\phi$   $0.875''$
- Tooth width b1  $0.894''$
- Tooth width B2  $2.683''$

### Double-Type "QD"

No. Teeth	Part Number	Bushing	De	Dp	Type	Max. Bore	L1	L2	C	Y	P	G	V	X	b1	B2	Weight(Approx.)	
																	With Hub	Rim Only
30	D120J30	J	15.170	14.350	C5	$4\frac{7}{16}$	$4\frac{1}{2}$	5	$7\frac{1}{4}$	$1\frac{1}{32}$	$\frac{25}{32}$	$\frac{2}{32}$	$\frac{5}{32}$	$3\frac{3}{16}$	.894	2.683	97.8	78.0
35	D120J35	J	17.570	16.734	C5	$4\frac{7}{16}$	$4\frac{1}{2}$	5	$7\frac{1}{4}$	$1\frac{1}{32}$	$\frac{25}{32}$	$\frac{2}{32}$	$\frac{5}{32}$	$3\frac{3}{16}$	.894	2.683	112	93.0
45	D120J45	J	22.350	21.502	C5	$4\frac{7}{16}$	$4\frac{1}{2}$	5	$7\frac{1}{4}$	$1\frac{1}{32}$	$\frac{25}{32}$	$\frac{2}{32}$	$\frac{5}{32}$	$3\frac{3}{16}$	.894	2.683	157	138
60	D120M60	M	29.520	28.661	C6	$5\frac{1}{2}$	$6\frac{3}{4}$	$6\frac{3}{4}$	9	$2\frac{9}{32}$	$1\frac{23}{32}$	$1\frac{2}{32}$	$\frac{27}{32}$	$5\frac{1}{16}$	.894	2.683	271	234

- Pitch  $1\frac{3}{4}''$
- Roller  $\phi$   $1.000''$
- Tooth width b1  $0.894''$
- Tooth width B2  $2.818''$

### Double-Type "QD"

No. Teeth	Part Number	Bushing	De	Dp	Type	Max. Bore	L1	L2	C	Y	P	G	V	X	b1	B2	Weight(Approx.)	
																	With Hub	Rim Only
35	D140J35	J	20.490	19.523	C5	$4\frac{7}{16}$	$4\frac{1}{2}$	5	$7\frac{1}{4}$	$\frac{31}{32}$	$\frac{23}{32}$	$\frac{19}{32}$	$\frac{7}{32}$	$3\frac{3}{16}$	.894	2.818	137	128
45	D140J45	J	26.080	25.087	C5	$4\frac{7}{16}$	$4\frac{1}{2}$	5	$7\frac{1}{4}$	$\frac{31}{32}$	$\frac{23}{32}$	$\frac{19}{32}$	$\frac{7}{32}$	$3\frac{3}{16}$	.894	2.818	195	176
60	D140M60	M	34.440	33.438	C6	$5\frac{1}{2}$	$6\frac{3}{4}$	$6\frac{3}{4}$	9	$2\frac{7}{32}$	$1\frac{23}{32}$	$1\frac{19}{32}$	$\frac{25}{32}$	$5\frac{1}{16}$	.894	2.818	339	302

- Pitch  $2''$
- Roller  $\phi$   $1.125''$
- Tooth width b1  $1.119''$
- Tooth width B2  $3.424''$

### Double-Type "QD"

No. Teeth	Part Number	Bushing	De	Dp	Type	Max. Bore	L1	L2	C	Y	P	G	V	X	b1	B2	Weight(Approx.)	
																	With Hub	Rim Only
35	D160M35	M	23.420	22.312	C6	$5\frac{1}{2}$	$6\frac{3}{4}$	$6\frac{3}{4}$	9	$2\frac{3}{64}$	$1\frac{1}{32}$	$1\frac{1}{32}$	$\frac{39}{64}$	$5\frac{3}{16}$	1.119	3.424	259	222
45	D160N45	N	29.800	28.671	C6	6	$8\frac{1}{8}$	$8\frac{1}{8}$	10	$2\frac{17}{32}$	$2\frac{23}{64}$	$2\frac{5}{32}$	$\frac{21}{32}$	$6\frac{1}{4}$	1.119	3.424	377	340
60	D160N60	N	39.360	38.215	C6	6	$8\frac{1}{8}$	$8\frac{1}{8}$	10	$2\frac{17}{32}$	$2\frac{23}{64}$	$2\frac{5}{32}$	$\frac{21}{32}$	$6\frac{1}{4}$	1.119	3.424	509	472

Sprockets

# No.200 | Sprockets with QD Bushings

- Pitch **2 1/2"**    □ Roller  $\phi$  **1.562"**
- Tooth width B1 **1.389"**

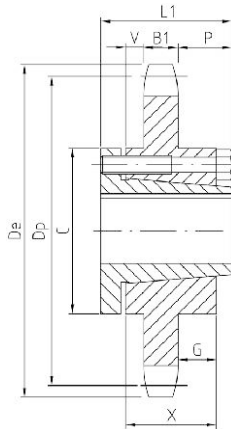

QD-TYPE C1

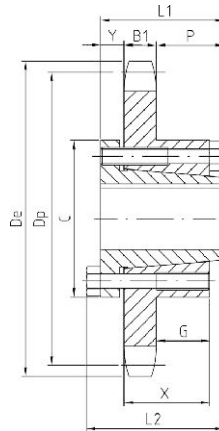

QD-TYPE C



## Single-Type "QD"

No. Teeth	Part Number	Bushing	De	Dp	Type	Max. Bore	L	L	C	Y	P	G	V	X	B1	Weight(Approx.)	
																With Hub	Rim Only
12	200F12	F	10.830	9.660	C	3 <sup>9</sup> / <sub>16</sub>	3 <sup>9</sup> / <sub>8</sub>	4	6 <sup>9</sup> / <sub>8</sub>	1	1 <sup>5</sup> / <sub>16</sub>	1 <sup>1</sup> / <sub>8</sub>		2 <sup>1</sup> / <sub>2</sub>	1.389	25.5	24
13	200J13	J	11.640	10.447	C	4 <sup>7</sup> / <sub>16</sub>	4 <sup>1</sup> / <sub>2</sub>	5	7 <sup>1</sup> / <sub>4</sub>	1 <sup>3</sup> / <sub>16</sub>	2	1 <sup>1</sup> / <sub>8</sub>		3 <sup>3</sup> / <sub>16</sub>	1.389	50.5	32
14	200J14	J	12.460	11.235	C											57.5	39
15	200J15	J	13.260	12.025	C											62.5	44
16	200J16	J	14.070	12.815	C	4 <sup>7</sup> / <sub>16</sub>	4 <sup>1</sup> / <sub>2</sub>	5	7 <sup>1</sup> / <sub>4</sub>	1 <sup>3</sup> / <sub>16</sub>	2	1 <sup>1</sup> / <sub>8</sub>		3 <sup>3</sup> / <sub>16</sub>	1.389	68.5	50
17	200M17	M	14.870	13.605	C1	5 <sup>1</sup> / <sub>2</sub>	6 <sup>3</sup> / <sub>4</sub>	6 <sup>3</sup> / <sub>4</sub>	9	2 <sup>2</sup> / <sub>32</sub>	2 <sup>2</sup> / <sub>32</sub>	2 <sup>9</sup> / <sub>16</sub>	1 <sup>1</sup> / <sub>2</sub>	5 <sup>9</sup> / <sub>16</sub>	1.389	113	76
18	200M18	M	15.680	14.397	C1											119	82
19	200M19	M	16.480	15.910	C1											125	88
20	200M20	M	17.290	15.982	C1											134	97
21	200M21	M	18.090	16.775	C1											140	103
22	200M22	M	18.890	17.567	C1											149	112
23	200M23	M	19.690	18.360	C1											157	120
24	200M24	M	20.490	19.152	C1											168	131
25	200M25	M	21.290	19.947	C1											175	138
26	200M26	M	22.090	20.740	C1											185	148
28	200M28	M	23.690	22.330	C1											205	168
30	200M30	M	25.290	23.917	C1											227	190
32	200M32	M	26.880	25.505	C1											251	214
35	200M35	M	29.280	27.890	C1											265	228
40	200M40	M	33.270	31.865	C1	5 <sup>1</sup> / <sub>2</sub>	6 <sup>3</sup> / <sub>4</sub>	6 <sup>3</sup> / <sub>4</sub>	9	2 <sup>2</sup> / <sub>32</sub>	2 <sup>2</sup> / <sub>32</sub>	2 <sup>9</sup> / <sub>16</sub>	1 <sup>1</sup> / <sub>2</sub>	5 <sup>9</sup> / <sub>16</sub>	1.389	315	278
45	200N45	N	37.250	35.840	C1	5 <sup>7</sup> / <sub>8</sub>	8 <sup>7</sup> / <sub>8</sub>	8 <sup>7</sup> / <sub>8</sub>	10	3 <sup>1</sup> / <sub>32</sub>	3 <sup>1</sup> / <sub>32</sub>	3 <sup>9</sup> / <sub>16</sub>	1 <sup>1</sup> / <sub>16</sub>	6 <sup>1</sup> / <sub>4</sub>	1.389	405	348
54	200N54	N	44.420	42.995	C1	5 <sup>7</sup> / <sub>8</sub>	8 <sup>7</sup> / <sub>8</sub>	8 <sup>7</sup> / <sub>8</sub>	10	3 <sup>1</sup> / <sub>32</sub>	3 <sup>1</sup> / <sub>32</sub>	3 <sup>9</sup> / <sub>16</sub>	1 <sup>1</sup> / <sub>16</sub>	6 <sup>1</sup> / <sub>4</sub>	1.389	535	478
60	200M60	N	49.200	47.767	C1	5 <sup>7</sup> / <sub>8</sub>	8 <sup>7</sup> / <sub>8</sub>	8 <sup>7</sup> / <sub>8</sub>	10	3 <sup>1</sup> / <sub>32</sub>	3 <sup>1</sup> / <sub>32</sub>	3 <sup>9</sup> / <sub>16</sub>	1 <sup>1</sup> / <sub>16</sub>	6 <sup>1</sup> / <sub>4</sub>	1.389	665	608